



REQUEST FOR PROPOSALS

(Sand City INVITES CONSULTANTS TO SUBMIT THEIR PROPOSALS FOR):

SAND CITY MULTI-USE BIKE TRAIL FINAL DESIGN

You are invited to submit your proposal for the services to complete the above project. Proposals are due via email by **July 6, 2026** (extended by two weeks from original 6/22/26 deadline), 5:00 PM PST to nmcilroy@sandcityca.org

The Request for Proposals and supplemental information, if any, are available on the [Sand City Website](#)¹ or may be obtained by contacting nmcilroy@sandcityca.org.

¹ <https://www.sandcity.org/our-community/advanced-components/rfp-posts-list>



Date: May 20, 2026
TO: Interested Consultants
FROM: Vibeke Norgaard, City Manager
SUBJECT: Sand City Multi-use Trail Project

INVITATION

You are invited to submit a Proposal for the referenced services.

This request is seeking services that qualify as “Architecture and Engineering” (A&E) services. Sand City will negotiate the project budget after selection of the top ranked consultant. The cost proposal is not requested until the consultants have been final ranked based upon their submitted technical proposal. Upon notification, if your firm is selected as the top ranked firm, Sand City will require completion of the appropriate Caltrans cost proposal to initiate contract negotiations.

Please submit one (1) digital copy of your Proposal to City Hall at nmcilroy@sandcityca.org.

There is no requirement to submit a paper copy of your proposal. Proposals received after the date and time specified above will not be considered.

Proposals shall be considered firm offers to enter into a contract, as described in this RFP, for a period of one hundred and twenty (120) days from the time of submittal.

Proposals and inquiries relating to this Request for Proposals shall be submitted to:

nmcilroy@sandcityca.org

Email inquiries, including the submittal of the Proposal, relating to this Request for Proposals should include “Sand City Multi-use Trail – Final Design” in the subject header.

BACKGROUND

The City of Sand City (“City”) encompasses approximately 350 land acres and is located on the Monterey Peninsula, approximately 120 miles south of San Francisco. With 1½ miles of coastal frontage along the Monterey Bay, the City lies along the scenic Highway One freeway which bisects the City from north to south. The City has developed a 30% design and plans for the Sand City Multi-use Trail Project (“Project”). The Project is located within an existing 100-foot Railroad Right-of-Way (“TAMC RR ROW”) owned by the Transportation Agency for Monterey County (TAMC). The Project will close a critical 1-mile gap in the Monterey Bay Coastal Recreation Trail (MBCRT).

The Project goals are to enhance regional trail connectivity while promoting alternative and sustainable transportation options such as walking and cycling. By incorporating landscaped areas and establishing a continuous green belt along the corridor, the Project will improve local aesthetics and help create a safer and more attractive public space for the community. The project will also prioritize accessibility, and ADA-compliant designs to ensure safe and inclusive access for users of all ages and abilities. Additionally, by encouraging non-motorized travel, the project aims to reduce vehicle emissions and support broader efforts to improve air quality and reduce pollution throughout the region.

The Project has garnered strong regional support from local jurisdictions, public officials, and community organizations including the Cities of Marina, Del Rey Oaks, Pacific Grove, Seaside, and Monterey, California State University Monterey Bay (CSUMB), the Monterey Peninsula Unified School District (MPUSD), the Monterey County Board of Supervisors, Senator John Laird, Congressman Jimmy Panetta, TAMC, and Monterey-Salinas Transit (MST).

The 30% design includes preliminary civil engineering, landscaping, planting, irrigation, and lighting components. In compliance with the California Environmental Quality Act (CEQA), a Notice of Exemption (NOE) has been prepared and filed for the project. After a site visit on April 28, 2026, Caltrans indicated the Project likely qualifies for a Categorical Exclusion (CE) under the National Environmental Policy Act (NEPA) consistent with the requirements of the U.S. Department of Transportation.

PROJECT DESCRIPTION

The Project will extend approximately one mile within the TAMC RR ROW defined above, beginning at the intersection of Canyon Del Rey Boulevard (State Route 218) and Del Monte Avenue in the City of Seaside, and continuing north to the intersection of Playa Avenue at California Avenue in the City of Sand City, where it will connect to the future MST SURF! Busway station.

The Project incorporates a variety of amenities and intersection improvements to enhance safety, accessibility, and user experiences. Key intersection features include protected crossings with curb extensions, high visibility crosswalks, and signage and striping improvements to enhance safety for trail users. The Project also includes landscaping, strategically placed lighting for visibility and security, directional signage, off-street parking areas at multiple access points, public gathering areas with benches and picnic tables, and several outdoor exercise stations with durable fitness equipment.

This RFP will be used by the City to select a consultant to provide a range of professional services including project management, land surveying, engineering design, right-of-way design and coordination, utility relocation, bidding support, NEPA reports and supporting technical surveys, design support during construction, community and stakeholder outreach, grant application support, and related services as further described in this RFP. The Project design and final alignment shall be reviewed and approved by the City.

Attachment A is a draft Scope of Work. A final Scope of Work will be made a part of the professional services agreement between Sand City and the consultant. A copy of the City's standard agreement is included in Attachment B. Any requests to modify the standard contract provisions must be made as part of the response to this RFP. A single document will be prepared between the Consultant and the City consistent with the provisions of these attachments.

It is important that the consultant has the capability to work closely with City staff. The consultant must be prepared to undertake whatever liaison and meetings are required to satisfy this requirement.

PROJECT SCHEDULE

The Project design, NEPA clearance and right-of-way certification is anticipated to take approximately 12 months to complete, starting in July 2026 and being completed by July 2027.²

SELECTION PROCESS

The City staff will establish a staff level review committee to review the proposals. This review may be followed by an oral interview with the top ranked firm(s).

Responses to this RFP must be complete. Responses that do not include the proposal content requirements identified within this RFP and subsequent addenda may be considered incomplete and receive no further consideration.

Proposals will be evaluated according to each Evaluation Criteria and scored on the zero to

² Please note in the response if any additional time is needed or anticipated.

five-point rating scale shown in the table below. The scores for the Evaluation Criteria will then be multiplied according to their assigned weight to arrive at a weighted score for each firm. A firm’s proposal with a high weighted total will be deemed of higher quality than a proposal with a lesser weighted total.

Rating Scale		
0	Not Acceptable	Non-responsive, fails to meet RFP specifications. The approach has no probability of success in achieving project objectives per the RFP.
1	Poor	Below average, falls short of expectations, is substandard to that which is the average or expected norm, has a low probability of success in achieving project objectives per the RFP.
2	Fair	Has a reasonable probability of success, however, some objectives may not be met.
3	Average	Acceptable, achieves all objectives in a reasonable fashion per the RFP. This will be the baseline score for each item with adjustments based on interpretation of the proposal by Selection Committee.
4	Above Average/Good	Very good probability of success, better than that which is average or expected as the norm. Achieves all objectives per RFP requirements and expectations.
5	Excellent/Exceptional	Exceeds expectations, very innovative, clearly superior to that which is average or expected as the norm. Excellent probability of success and in achieving all objectives and meeting RFP requirements and expectations.

The Proposal Evaluation Criteria and their respective weights are as follows:

No.	Criteria	Weight
1	Project Team Qualifications and Experience	6
2	Demonstrated Project Understanding and Technical Knowledge	6
3	Scope of Work and Methodology	5
4	Project Schedule and Delivery Capacity	3
5	References and Past Performance	2

AWARD PROCESS

Based on the recommendations of the review committee, the City will issue a “Notice of Intent to Award” notice to all responders, indicating staff’s intent to negotiate with the specific firm considered to be the most qualified consultant and the ranking of each of the firms.

City staff will then negotiate a final Scope of Work and a Cost Proposal for the Project with that consultant. The final Scope of Work will include a full description of each task, a description of

deliverable products, and a schedule of the due dates for the deliverable products and other important milestones. The Cost Proposal shall use the appropriate Caltrans cost proposal format (Sample Cost Proposal 1) and backup documentation shall be provided showing the estimated cost per task. Upon successful completion of negotiations, the consultant will be recommended to the City Council for final selection and contract approval.

Should the most qualified consultant and the City fail to successfully negotiate a final scope of work and a mutually agreed upon costs for these consulting services, then the City reserves the right to enter negotiations with the next most qualified consultant for performance of the work or re-issue an RFP.

The City reserves the right to accept or reject all submitted proposals, to waive minor irregularities and to request additional information or revisions to offers. The City reserves the right to negotiate contract terms with the top-ranked firm based on qualifications. If the City is unable to come to an agreement with the top-ranked firm, then the City reserves the right to terminate negotiations and start negotiations with the second-ranked firm or re-issue an RFP.

QUESTION & ANSWERS, REQUESTS FOR CLARIFICATION OR EXCEPTIONS, ADDENDA

This Request for Proposals and any addenda will be posted on the City's website at [RFP/Bids](#).³ Questions and answers regarding the request for proposals will also be posted on the website. All prospective proposers are responsible for checking the website for any and all addenda to this RFP, and the proposal must acknowledge all addenda issued in order to be considered responsive. To receive email notifications of addendums to this Request for Proposals, prospective proposers must submit an email request to snorton@sandcityca.org.

Any requests for clarification or exceptions to requirements in this Request for Proposals must be received by the City no later than **June 22, 2026**, to guarantee response or consideration. Responses to questions concerning this RFP submitted before this deadline will be posted on the City's website.

PREVAILING WAGE

A portion of this work is prevailing wage work. For any prevailing wage work proposed by the proposing firm or a subconsultant (any tier) under this contract, in accordance with Labor Code Section 1720 et seq., employees must be paid at least the prevailing rate wages for public works performed on the Project. The proposing firm and any applicable subconsultant (any tier) must register with the Department of Industrial Relations (DIR) prior to contract award, must remain registered for the entire term of the contract, and must submit certified payroll records to DIR at least monthly for such work.

Firms can register at:

https://services.dir.ca.gov/gsp?id=gsp_register_v1

³ Link: <https://sandcity.org/rfps-rfq/>

DEBARMENT

In accordance with Appendix II of 2 CFR 200, consultants and subconsultant (any tier) shall not perform work on this Project if they are debarred, suspended, or otherwise excluded from or ineligible for participation in federal assistance programs. The Excluded Parties List System (EPLS) is maintained by the General Services Administration (GSA) and available at the following website: <https://sam.gov/SAM/>

FINANCIAL MANAGEMENT, ACCOUNTING SYSTEM, AND AUDIT REQUIREMENTS

The Consultant shall have an adequate financial management and accounting system as required by 48 CFR 31 and 2 CFR 200.

The selected consultant shall comply with Chapter 10.1.3 of the LAPM regarding the A&E Consultant Contract Audit and Review process. All proposed contracts and supporting documents are subject to audit or review by Caltrans' Independent Office of Audits and Investigations, other state audit organizations, or the federal government.

SUBMITTAL REQUIREMENTS/PROPOSAL FORMAT

All interested firms are required to submit one (1) digital copy of their Proposal to perform the requested consulting services. The Proposal must include the names and qualifications of all personnel to be employed on the project. The Proposal should provide a short description of the firm's experience with projects that relate to this Scope of Work (Attachment A). A list of relevant past clients should be included.

A. Cover Letter

The letter shall be on letterhead and include the proposer's contact name, mailing address, telephone number, facsimile number, and email address. The letter will address the proposer's understanding of the services being requested and any other pertinent information the proposer believes should be included.

The name, address, telephone number, and email address of the person authorized to represent the firm with respect to all notices, negotiations, discussions, and other communications relating to this proposal, to any negotiation relating to the contract should be included in the letter.

The letter shall be signed by the individual authorized to bind the Consultant to the representations, commitments, and statements in the proposal.

B. Project Team Qualifications and Experience

The Proposal shall clearly identify a Project Manager and include the names and qualifications of all personnel of the proposed team to be assigned to the contract and a chart representing

the proposed organizational structure of the team. The Proposal shall demonstrate that the key personnel have the time available to work on the project. Experience with context sensitive design, greenbelt or corridor trail planning, landscape integrated transportation projects, and multimodal corridor improvements will be strongly considered.

C. Demonstrated Project Understanding and Technical Knowledge

The Proposal shall include the assigned project team’s demonstrated knowledge of expertise and experience with providing similar services and completing similar types of contracts. Proposals will be evaluated on the Consultant’s demonstrated understanding of the City’s vision for a connected greenbelt corridor that prioritizes bicycle and pedestrian mobility while maintaining aesthetic and environmental character.

D. Scope of Work and Methodology

The City has provided a draft scope of work for the project in Attachment A, Scope of Work. The Proposal shall provide a scope of work consistent with the City’s proposed scope along with proposed modifications, additions, or deletions as necessary to accomplish the overall project objectives. Deviations from the City’s scope of work will be clearly listed and described for each task.

E. Project Schedule and Delivery Capacity

The Proposal must include availability of the project team to conduct work within the anticipated timeframes.

F. References and Past Performance

The Proposal shall include at least three (3) recent references from past clients for similar types of work for the consultant and each subconsultant.

G. Addenda Acknowledgement

The Proposal must include a signed Addenda Acknowledgement form (see Attachment C) acknowledging each addenda issued.

H. Disclosure of Lobbying Activities

The Proposal must include LAPM Exhibit 10-Q: Disclosure of Lobbying Activities if the consultant has performed any lobbying activities that require disclosure.

PROPOSED SCHEDULE

Date/ Timeframe	Task
May 20, 2026	RFP Re-released
June 23, 2026	Deadline for questions and/or requests for clarification or exceptions by 5:00 pm PST
July 6, 2026	Proposals due by 5:00 pm noon PST - Extended
Week of July 13, 2026	Hold interviews (if necessary)
August 2026	Bring contract to Sand City Council or approval

MISCELLANEOUS

A. Modification or Withdrawal of Submittals

Any Proposals received prior to the date and time specified above for receipt may be withdrawn or modified by written request of the proposer. To be considered, however, the modified Proposal must be received by the time and date specified above.

B. Property Rights

Any Proposals received within the prescribed deadline become the property of Sand City and all rights to the contents therein become those of Sand City.

C. Confidentiality

Before award of the contract, all Proposals will be designated confidential to the extent permitted by the California Public Records Act. After award of the contract (or if not awarded, after rejection of all Proposals), all responses will be regarded as public records and will be subjected to review by the public. Any language purporting to render all or portions of the Proposal confidential will be regarded as non-effective and will be disregarded.

D. Amendments to Request for Qualifications

Sand City reserves the right to amend the Request for Proposals by addendum before the final Proposal submittal date.

E. Non-Commitment of Sand City

This Request for Proposals does not commit Sand City to award a contract, to pay any costs incurred in the preparation of a Proposal for this request, or to procure or contract for services. All products used or developed in the execution of any contract resulting from this Request for Proposals will remain in the public domain at the completion of the contract.

F. Conflict of Interest

The prospective consultant shall disclose any financial, business or other relationship with Sand City that may have an impact upon the outcome of this contract or Sand City's construction project. The prospective consultant shall also list current clients who may have a financial interest in the outcome of this contract or Sand City projects that will follow. In particular, the prospective consultant shall disclose any financial interest or relationship with any construction company that might submit a bid on Sand City projects.

G. Nondiscrimination

The prospective consultant must certify compliance with nondiscrimination requirements of Sand City pertaining to the development, implementation and maintenance of a nondiscrimination program. The prospective consultant's signature affixed to and dated on the cover letters shall constitute a certification under penalty of perjury under the laws of the State of California that the proposer has, unless exempted, complied with the nondiscrimination program requirements of Government Code Section 12990 and Title 2, California Code of Regulations, Section 8103.

H. Final Selection and Protests

The RFP process is considered concluded when a “Tentative Award” letter is sent to all participating consultants indicating which consultant will be recommended for Board approval. The firm recommended is not a final selection and no contract is certain until approved by Sand City City Council.

Protestants shall submit a detailed written statement of protest to:

nmcilroy@sandcityca.org

no later than five (5) business days after receipt of the Tentative Award letter described above.

QUESTIONS

If you need assistance or have any questions, please email the at nmcilroy@sandcityca.org

Attachments:

- A. Scope of Work
- B. Sample Sand City Standard Agreement for Professional Services
- C. Addenda Acknowledgement Form
- D. Project Limits
- E. 30% Design Plans including Aerial/ROW/Utility Survey and Photos Link
- F. Update to 30% Plans

Exhibits to Proposal

- A. Scope of Work and Schedule
- B. Budget and Sample Cost Proposal
- C. ADA Best Practices for Documents and Outreach
- D. Title VI Exhibit for Federal Contracts

This page is intentionally left blank.

ATTACHMENT A SCOPE OF WORK

PROJECT BACKGROUND

The City of Sand City (“City”) encompasses approximately 350 land acres and is located on the Monterey Peninsula, approximately 120 miles south of San Francisco. With 1½ miles of coastal frontage along the Monterey Bay, the City lies along the scenic Highway One freeway which bisects the city from north to south. The City has developed a 30% design and plans for the Sand City Multiuse Trail Project (“Project”). The Project is located within an existing 100-foot Railroad Right-of-Way owned by the Transportation Agency for Monterey County (TAMC). The Project will close a critical 1-mile gap in the Monterey Bay Coastal Recreation Trail (MBCRT).

The Project goals are to enhance regional trail connectivity while promoting alternative and sustainable transportation options such as walking and cycling. By incorporating landscaped areas and establishing a continuous green belt along the corridor, the Project will improve local aesthetics and help create a safer and more attractive public space for the community. The project will also prioritize accessibility, and ADA-compliant designs to ensure safe and inclusive access for users of all ages and abilities. Additionally, by encouraging non-motorized travel, the project aims to reduce vehicle emissions and support broader efforts to improve air quality and reduce pollution throughout the region.

The Project has garnered strong regional support from local jurisdictions, public officials, and community organizations including the Cities of Marina, Del Rey Oaks, Pacific Grove, Seaside, and Monterey, California State University Monterey Bay (CSUMB), the Monterey Peninsula Unified School District (MPUSD), the Monterey County Board of Supervisors, Senator John Laird, Congressman Jimmy Panetta, TAMC, and Monterey-Salinas Transit (MST).

The 30% design includes preliminary civil engineering, landscaping, planting, irrigation, and lighting components. In compliance with the California Environmental Quality Act (CEQA), a Notice of Exemption (NOE) has been prepared and filed for the project. The City anticipates that the Project will qualify for a Categorical Exclusion (CE) under the National Environmental Policy Act (NEPA), consistent with the requirements of the U.S. Department of Transportation.

GOALS

The design process shall be cooperative and interactive with stakeholders. Strong community outreach and participation will be a critical component to make the project more competitive for state, federal and private matching grant funds, and to fulfill Sand City’s commitment to Stakeholder Jurisdictions.

The goals of this scope of professional services are to perform engineering design, environmental reports and technical studies, landscape architecture, lighting and traffic engineering, bidding support and grant application support,. The design and final alignment shall be reviewed and approved by Sand City.

SCHEDULE

The Consultant shall develop a schedule with the following deadlines:

July 2026	Begin Design
July 2027 ⁴	Complete Design
August 2027	Construction Award (Anticipated)

STAKEHOLDER JURISDICTIONS

This is a multijurisdictional project. The following “Stakeholder Jurisdictions” shall be closely involved in the development of the Project design:

- City of Sand City (Project and Design Lead): Serves as the administrative and technical lead, managing the consultant contract, directing design development, and coordinating all stakeholder inputs.
- City of Seaside (Right-of-Way Owner and Stakeholder): Provides local oversight, technical review, and right-of-way entry coordination for project segments within its jurisdictional limits.
- Transit Agency of Monterey County (TAMC) (Right-of-way Owner and Stakeholder): Oversees project interfaces with the former Union Pacific Railroad right-of-way to ensure alignment with regional transit and corridor planning.
- Caltrans (NEPA Lead and Funding Oversight Agency): Serves as the National Environmental Policy Act (NEPA) lead agency, provides state-level project oversight, and manages the compliance review required for grant fund releases.

The City of Sand City is the Stakeholder team lead and will be making the final decisions on the final project design with concurrence of the rest of the stakeholder jurisdictions. It is anticipated that two (2), one hour long meetings will be held with the stakeholder

⁴ CONSULTANT must note in response if additional time is needed or anticipated to complete the design phase of the project.

jurisdictions and design consultant at the 65% plans and 95% plans milestones.

SCOPE OF WORK

The scope of work for this Project is organized into the following main areas intended to accomplish the Project goals. Note: the intersection of Canyon Del Rey (HWY 218) and Del Monte Blvd in Seaside may be excluded from the final scope at the City's discretion. Please include as a separate bid item:

- Project Management
- Final Landscape Design
- Engineering Design (Plans, Specifications, and Estimates - PS&E)
- Technical Support for Community Outreach (Graphics, maps, and technical analysis)
- Grant Application Support (As needed)
- Bidding Support

The consultant may propose a reorganization or consolidation of these tasks as well as any additional tasks needed to meet project goals. However, all required tasks, and any optional tasks must be included in the proposal.

Task 1: Project Management

Task 1.1 Project Management:

Consultant shall serve as overall Project Manager during the entire duration of the Project. General project management responsibilities include:

- Prepare and update master project schedule
- Coordinate progress meetings
- Effectively communicate with City Staff regarding progress
- Participate in preparing plans and technical documents for future grant applications as needed
- Provide coordination with other agencies as needed
- Manage subconsultants
- Oversee all the project components listed in this Scope of Work
- Effectively manage budget, schedule, and resources
- Ensure Quality Assurance and Quality Control Measures are completed
- Prepare invoices at the end of each month for the previous month's work
- Prepare the plans and technical specifications and consolidate all required bid documents

Task 1.2 Progress Meetings:

Consultant shall provide meeting coordination and oversight. At the start of this Project, a kick-off meeting shall be scheduled to establish the project team, review the scope of work and project schedule and establish roles and lines of communications. For estimating purposes, Consultant should anticipate monthly coordination meetings for the duration of the project. The appropriate subconsultants shall be in attendance at these team meetings. The kick-off meeting shall be in person at Sand City Hall. Progress meetings may be in person or via teleconferences and video-based meetings, as necessary and where possible to save costs. Consultant shall prepare agendas and meeting minutes highlighting decisions made and action items and distribute them to the City and design team.

Task 1.3 Review of Existing Documents and Environmental Impact Report:

Consultant shall review the goals and objectives of the Project, as described in this RFP and in the City's Project Description. The Consultant shall understand the importance of outreach, stakeholder engagement, and consensus building in achieving the final design and alignment.

The following environmental review status applies to this Project and defines the required scope of work:

- CEQA Compliance: In compliance with the California Environmental Quality Act (CEQA), a Notice of Exemption (NOE) has already been prepared and filed for the project. No further CEQA documentation is required under this contract.
- NEPA Compliance: The Caltrans Environmental team reviewed the Preliminary Environmental Study (PES) and conducted a formal field review in April 2026 to determine applicable National Environmental Policy Act (NEPA) requirements. Based on this review, Caltrans confirmed that the Project qualifies for a Categorical Exclusion (CE) under 23 CFR 771 [1]. The scope of technical studies listed in Task 4.2.6 directly reflects the requirements finalized during the April 2026 Caltrans evaluation. Final NEPA clearance is pending Caltrans' review and approval of the specific deliverables outlined below

Task 1.4 Field Review of Project alignment:

The consultant shall review the proposed Project alignment and be prepared to go out into the field to walk the alignment. City staff shall facilitate the field walk. City staff and other parties as determined by City shall be invited to participate.

Task 1.5 Agreements and Permits:

Consultant shall confer with State, Federal and local agencies, as appropriate, to determine the permits and permitting requirements required for the Project. Consultant shall assist in the preparation and submittal of all permits and agreements:

- Caltrans encroachment permit for the trail termination near the intersection of Canyon Del Rey Blvd (State Route 218) and Del Monte Avenue. This item may not be necessary, include as a separate item that may not be necessary at the City's discretion.

- City of Seaside Encroachment Permit – currently in-progress; include as a separate item that may not be necessary at the City’s discretion.
- TAMC Use Agreement – currently in-progress; include as a separate item that may not be necessary at the City’s discretion.

Task 2: Land Surveying

Task 2.1 Review Available Survey Data:

The Consultant shall obtain and review all available City-provided survey data to identify if any additional information is necessary to complete the PS&E and Right-of-Way (ROW) design. The City has prepared an Aerial Survey, ROW Survey, and Utility Survey as part of the 30% Design. The existing Aerial Survey established horizontal and vertical control in California State Plane coordinates (NAVD88 datum), providing visible plan features, spot elevations with a 1’ contour interval, and 0.2’ resolution color orthophotos. The existing ROW Survey includes corridor monumentation and boundary determination. A Record of Survey for monument preservation will be made available by the City prior to construction.

Deliverables (Baseline Review): Memorandum detailing the assessment of available data, identifying any design gaps, and including site photographs and maps.

Task 2.2 Optional Additive Bid Item – Supplemental Field Surveying:

To maintain a minimal baseline scope, any required supplemental field surveying shall be scoped and priced as a separate, optional additive bid item. If requested by the City, the Consultant shall provide targeted topographic, ROW/parcel, or underground utility mapping (Quality Level B/C) necessary to finalize design features that require higher precision than the 30% aerial data. This includes, but is not limited to:

- Detailed ground topography for at-grade crossings, parking areas, retaining walls, ADA ramps, conforms, and stormwater control measures.
- Localized constraints analysis.

Deliverables (Optional Survey - If Activated): Civil3D/AutoCAD base map files, digital terrain models (DTM), certified points lists, and updated GIS/PDF files matching Sand City standards. All text, tables, and spreadsheets shall be delivered in native Word and Excel formats.

Task 3: Final Landscape Design

Task 3.1 Landscape/Planting/Irrigation/Amenities Plans:

Consultant shall prepare a landscape/planting/irrigation/amenities plan for the Project. Consultant shall present initial designs based on the 30% plans to the City and if requested to Stakeholder Jurisdictions for discussion and approval of the final landscape and aesthetic concept to be incorporated into the Project plans. The plan should include the following elements for each of the three concepts:

1. Landscape design with plant palettes, wall and structure treatments, hardscape palette, irrigation availability, and interpretative opportunities
2. Cost estimates for various elements
3. Illustrative sections and sketches
4. Stakeholder Jurisdiction input summary
5. Determination of approvals and agreements required by Stakeholder Jurisdictions
6. Final Landscape and Aesthetics Plan Exhibits

Task 4: Engineering Design (PS&E)

Consultant shall perform all work in accordance with Federal and State of California laws, regulations, and standards; Federal Highway Administration (FHWA) standards; and Caltrans standards.

Task 4.1 Plans, Specifications and Cost Estimate (PS&E):

Consultant shall prepare the engineering design for the Project, from the current 30% design to final design. Designs shall consider opportunities for innovative features and approaches and shall consider project area constraints. The Consultant shall refer to the project description and 30% Plans for specific project improvements to be designed. The 30% Plans will be made available to consultant, in both PDF and AutoCAD. The consultant shall provide final design services, including complete PS&E deliverables at 60%, 90%, and 100% design milestones.

The construction documents included in this task include:

- Construction Plans
- Project Specifications and Special Provisions, prepared using the latest Caltrans Standard Specifications and in compliance with Chapter 12 of the Caltrans Local Assistance Procedures Manual (LAPM), including applicable federal requirements.
- Quantity Calculations
- Engineer's Opinion of Probable Construction Cost (OPCC)

The Consultant shall write a complete set of technical specifications based on the latest Caltrans Standard Specifications. The Consultant shall develop a complete set of special provisions that adhere to and include all federal requirements. The following plan sheets are anticipated, but not limited to:

1. Title Sheet and Sheet Index
2. Key Map, Abbreviations and General Notes
3. Horizontal and Vertical Control
4. Typical Cross Sections
5. Construction Details

6. Demolition Plans
7. Trail Plan and Profiles
8. Parking Area Improvements
9. Temporary Water Pollution Control Plans
10. Erosion Control and Habitat Protection
11. Grading Plans
12. Drainage Plan, Profiles, Details (Including Minor Structures) and Quantities
13. Construction Area Signs
14. Proposed Construction Staging (temporary material staging within project limits may be permitted, subject to City approval) and include Details and Quantities.
15. Plans shall identify project specific traffic handling requirements and access requirements for vehicles, bicycles and pedestrians. Traffic control plans shall be prepared and implemented by the contractor.
16. Pavement Delineation Plans, Details and Quantities
17. Sign Plans, Details and Quantities
18. Retaining Wall Plans, Profiles, Details and Quantities if required
19. Traffic Signal Modification (Canyon Del Rey Blvd at Del Monte Ave) if required
20. Electrical Plans (Trail, Intersection and Overcrossing Lighting, Irrigation Controls)
21. Landscaping and Irrigation Plans, Details and Quantities

Task 4.1.2 60% PS&E:

The Consultant shall prepare a 60% design that reflects the 30% plan set and stakeholder comments. Consultant shall provide City and any Stakeholder Jurisdictions if requested by City with a set of draft 60% PS&E for review and comment. The 60% PS&E shall address issues such as materials specification, bid item list, and bid item measurement and payment.

Task 4.1.3 90% PS&E:

The Consultant shall prepare a 90% design that reflects the 60% plan set and the stakeholder jurisdiction comments. Consultant shall provide City and all Stakeholder Jurisdictions with a set of draft 90% PS&E for final review and comment.

Task 4.1.4 100% PS&E:

The Consultant shall prepare a 100% design that reflects the 90% plan set and the comments from City and Stakeholder Jurisdictions based on that plan set. Consultant shall provide City and Stakeholder Jurisdictions if requested by City with a set of 100% PS&E. Final Plans and specifications shall be signed and sealed by a California Registered Professional Engineer.

Task 4.2 Analysis and Reports:

This task includes the preparation of technical reports to support the Project design.

Task 4.2.5 Stormwater Control Plan for Trailside Parking Lots:

The Consultant shall prepare a Post-Construction Stormwater Control Plan (SWCP), including necessary design calculations and facility sizing, exclusively for the project's trailside parking areas. This SWCP shall be developed in accordance with Resolution No. R3-2013-0032 (Central Coast Post-Construction Requirements) and the City's latest adopted Stormwater Technical Guide and templates. Multi-use trail paths are exempt from post-construction stormwater control requirements and are excluded from this SWCP scope. Applicable design standards are limited to site planning/source control and water quality treatment/retention sizing for the parking surfaces only. A preliminary SWCP shall be included with the 60% design submittal, and a final SWCP shall be included with the Final PS&E submittal. Preparation of construction-phase Stormwater Pollution Prevention Plans (SWPPP), risk calculations, or SMARTS permit registration is excluded from this scope and shall be the responsibility of the construction contractor.

Task 4.2.6 Caltrans Environmental Certification and Commitments Record:

Consultant shall prepare technical documents that are consistent with the project description. Sand City assumes no additional CEQA documentation will be required. Sand City has a Preliminary Environmental Studies (PES) document approved by Caltrans. The NEPA⁵ requirements include the following documents:

- Biological Report
 - Technical report discussing plant and wildlife species (common and special-status) found within the project area and an impact assessment
 - This report must include a discussion of Monterey spineflower – specifically the negative and beneficial direct (if any) and indirect effects of the project, as well as avoidance and minimization measures (e.g. designing the trail around the known population, ESA fencing)
 - Other recommendation avoidance and minimization measures (e.g. nesting bird surveys)
- Area of Potential Effects (APE) Map: Prepared in accordance with Caltrans Section 106 guidelines for Caltrans District 5 approval.
- Archeological Survey Report (ASR): A standard baseline cultural resources inventory report. *Note: Extended phase testing, evaluation reports (AER/HRCR), or historical architectural assessments are explicitly excluded from this scope and will be considered an amendment if required by Caltrans based on the ASR determination.*

⁵ Note that NEPA requirements may change with review of documents.

Please bid as an optional amendment.

- Native American consultation coordination with Caltrans
- Hazardous Waste Technical Memorandum: A high-level screening memorandum (Initial Site Assessment screening) to satisfy PES requirements.
- Environmental Commitment Record
 - Table summarizing all environmental commitments for the project across all permit documents and technical reports

Task 4.2.9 Trail Lighting Design:

The Consultant shall perform a trail lighting design for the Project to ensure appropriate and safe lighting is provided and trail improvements are safe for users. This analysis shall include a photometrics analysis based on the light types shown on the 30% design plans. The Photometrics analysis will be used to determine the appropriate spacing of all new lights throughout the Project corridor and where the trail intersects with existing streets. Consultant shall submit analysis to Sand City and Stakeholder Jurisdictions for review and approval.

Task 4.2.10 Trailside Parking lot and Traffic Design,

Primarily this task will be to design approximately five (5) small trailside parking lots with a total of approximately 110 parking spaces along the corridor. Each parking lot will include 14-45 parking stalls and will require post construction stormwater measures.

This task shall may include improvements at the Caltrans intersection of Canyon Del Rey Blvd (State Route 218) and Del Monte Blvd. such striping improvements to separate the bicycle and pedestrian traffic and intersection control improvements for one crossing to connect the trail to the Monterey Bay Coastal Trail.⁶ Modifications to this intersection will need to be processed through Caltrans to obtain the appropriate permits and approvals. Based on the 30% design, it is anticipated that the Project will require a Design Engineering Evaluation Report (DEER) process, but the Consultant shall confirm this during the design phase. Please provide this as a separate bid item that may be excluded from the final scope at the City's discretion.

Task 4.3 Cost Estimates:

- The Consultant shall prepare an itemized estimate of probable construction cost for each submittal. While the City is handling the legal and administrative work for the Use Agreement and Easements, the Consultant shall include the estimated capital costs (e.g., market value or compensation amounts) for Temporary Construction Easements,

⁶ This intersection is located within the City of Seaside, so if Seaside receives funding to improve the full intersection than these improvements will not need to be done by the Consultant for Sand City.

permanent easements (if necessary), and utility relocations within the overall project estimate. Estimates shall also include costs for construction, environmental mitigations (as needed), permits, inspection, landscaping, equipment, plant costs and tests (if needed). Cost estimates should include an escalation factor to account for the potential year of construction. The consultant shall document assumptions and unit costs as part of the cost submittal.

Deliverables: Excel and Word files of cost estimates

Task 75: Community Outreach

Task 5.1 Community and Stakeholder Meetings and Design Workshops:

The Consultant shall provide technical data, maps, and high-quality graphics to support City-led outreach efforts. Please note that the City has been conducting public outreach since 2024. Consultant shall prepare visual simulations to clearly communicate the Project to the public for any additional outreach needed. The City will lead most aspects of community engagement, including developing any additional outreach plans, scheduling, public noticing, and facilitating all meetings and workshops. The Consultant's role is limited to providing the technical "backbone" for these interactions. The Consultant shall provide the technical materials listed above for the following anticipated rounds of outreach (approximately 7–11 meetings total):

- 1 Sand City City Council: Support for 2-3 meetings.
- 2 Stakeholder Jurisdictions: Support for 2-3 board / committee meetings.
- 3 Staff-level Coordination: Support 2-3 meetings.
- 4 Community Workshops: Support for 1-2 workshops in Sand City/Seaside.

Consultant Attendance: The Consultant shall attend the meetings listed above to act as a technical resource and answer specific engineering or design questions as requested by City staff.

Deliverables: Technical memos, high-resolution graphics, digital presentation slides, and visual simulations as requested by City staff.

Task 5.2 Grant Support:

Consultant shall provide Sand City with technical analysis assistance for future grant applications. Technical analyses may be cost/benefit analysis or other technical analyses as required by different grant programs.

Deliverables: Technical analysis such as cost estimates for trail construction.

This page is intentionally left blank.

ATTACHMENT B

Exhibit 10-R: A&E AGREEMENT

(For Local Assistance Federal-Aid Projects)

NOTE TO LOCAL AGENCY - BE SURE THAT YOUR LEGAL STAFF REVIEWS AND APPROVES ALL CONSULTANT CONTRACTS BEFORE EXECUTION. THIS AGREEMENT LANGUAGE IS RECOMMENDED LANGUAGE, EXCEPT ARTICLE XXXII TITLE VI ASSURANCES (APPENDICES A AND E MUST BE PHYSICALLY INCLUDED, UNMODIFIED, IN ANY FEDERAL-AID CONTRACT AND APPENDICES B-D MUST BE PHYSICALLY INCLUDED, UNMODIFIED, IN ANY FEDERAL-AID CONTRACT INVOLVING RIGHT OF WAY ACQUISITION). MODIFY AS RECOMMENDED BY YOUR OWN LEGAL STAFF AND TO FIT YOUR PARTICULAR REQUIREMENTS AND PROJECT.

THE FISCAL AND FEDERAL PROVISIONS ARE REQUIRED IN ALL FEDERALLY FUNDED CONTRACTS. THE ORIGINAL INTENT OF THE ARTICLE SHALL REMAIN, IF MODIFIED BY YOUR LEGAL STAFF.

THIS EXHIBIT CONTAINS FISCAL REQUIREMENTS FROM 2 CFR 200 AND IS TO BE USED FOR STATE-ONLY FUNDED CONTRACTS AS WELL.

[Note: italic text within brackets throughout the Articles is intended for instructional purposes only]

TABLE OF CONTENTS

	<u>Page</u>
ARTICLE I INTRODUCTION	3
ARTICLE II CONSULTANT’S REPORTS OR MEETINGS	4
ARTICLE III STATEMENT OF WORK	4
ARTICLE IV PERFORMANCE PERIOD	6
ARTICLE V ALLOWABLE COSTS AND PAYMENTS	6
ARTICLE VI TERMINATION.....	10
ARTICLE VII COST PRINCIPLES AND ADMINISTRATIVE REQUIREMENTS.....	11
ARTICLE VIII RETENTION OF RECORD/AUDITS.....	11
ARTICLE IX AUDIT REVIEW PROCEDURES.....	12
ARTICLE X SUBCONTRACTING.....	13
ARTICLE XI EQUIPMENT PURCHASE AND OTHER CAPITAL EXPENDITURES	15
ARTICLE XII STATE PREVAILING WAGE RATES	16
ARTICLE XIII CONFLICT OF INTEREST	19
ARTICLE XIV REBATES, KICKBACKS OR OTHER UNLAWFUL CONSIDERATION	19
ARTICLE XV PROHIBITION OF EXPENDING LOCAL AGENCY, STATE, OR FEDERAL FUNDS FOR LOBBYING	20
ARTICLE XVI NON-DISCRIMINATION CLAUSE AND STATEMENT OF COMPLIANCE.....	20
ARTICLE XVII DEBARMENT AND SUSPENSION CERTIFICATION.....	21
ARTICLE XVIII DISADVANTAGED BUSINESS ENTERPRISES (DBE).....	22
ARTICLE XIX INSURANCE	28

ARTICLE XX FUNDING REQUIREMENTS	29
ARTICLE XXI CHANGE IN TERMS.....	29
ARTICLE XXII CONTINGENT FEE.....	29
ARTICLE XXIII DISPUTES.....	30
ARTICLE XXIV INSPECTION OF WORK.....	30
ARTICLE XXV SAFETY	30
ARTICLE XXVI OWNERSHIP OF DATA.....	31
ARTICLE XXVII CLAIMS FILED BY LOCAL AGENCY’S CONSTRUCTION CONTRACTOR.....	31
ARTICLE XXVIII CONFIDENTIALITY OF DATA	32
ARTICLE XXIX NATIONAL LABOR RELATIONS BOARD CERTIFICATION.....	32
ARTICLE XXX EVALUATION OF CONSULTANT	33
ARTICLE XXXI PROMPT PAYMENT.....	33
ARTICLE XXXII TITLE VI ASSURANCES	33
ARTICLE XXXIII NOTIFICATION	38
ARTICLE XXXIV CONTRACT.....	38
ARTICLE XXXV SIGNATURES.....	39

ARTICLE I INTRODUCTION

- A. This AGREEMENT is between the following named, hereinafter referred to as, CONSULTANT and the following named, hereinafter referred to as, LOCAL AGENCY:

The name of the "CONSULTANT" is as follows:

(NAME OF CONSULTANT)

Incorporated in the State of California

The Project Manager for the "CONSULTANT" will be (NAME)

The name of the "LOCAL AGENCY" is as follows:

City of Sand City

The Contract Administrator for LOCAL AGENCY will be the City Manager or their designee

- B. The work to be performed under this AGREEMENT is described in Article III Statement of Work and the approved CONSULTANT's Cost Proposal dated (DATE). The approved CONSULTANT's Cost Proposal is attached hereto (Attachment #) and incorporated by reference. If there is any conflict between the approved Cost Proposal and this AGREEMENT, this AGREEMENT shall take precedence.
- C. CONSULTANT agrees to the fullest extent permitted by law, to indemnify, protect, defend, and hold harmless LOCAL AGENCY, its officers, officials, agents, employees and volunteers from and against any and all claims, damages, demands, liability, costs, losses and expenses, including without limitation, court costs and reasonable attorneys' and expert witness fees, arising out of any failure to comply with applicable law, any injury to or death of any person(s), damage to property, loss of use of property, economic loss or otherwise arising out of the performance of the work described herein, to the extent caused by a negligent act or negligent failure to act, errors, omissions, recklessness or willful misconduct incident to the performance of this AGREEMENT on the part of CONSULTANT, except such loss or damage which was caused by the sole negligence, or willful misconduct of LOCAL AGENCY, as determined by a Court of competent jurisdiction. The provisions of this section shall survive termination or suspension of this AGREEMENT.
- D. CONSULTANT in the performance of this AGREEMENT, shall act in an independent capacity. It is understood and agreed that CONSULTANT (including CONSULTANT's employees) is an independent contractor and that no relationship of employer-employee exists between the Parties hereto. CONSULTANT's assigned personnel shall not be entitled to any benefits payable to employees of LOCAL AGENCY.
- E. LOCAL AGENCY is not required to make any deductions or withholdings from the compensation payable to CONSULTANT under the provisions of the AGREEMENT, and is not required to issue W-2 Forms for income and employment tax purposes for any of CONSULTANT's assigned personnel. CONSULTANT, in the performance of its obligation hereunder, is only subject to the control or direction of the LOCAL AGENCY as to the designation of tasks to be performed and the results to be accomplished.
- F. Any third party person(s) employed by CONSULTANT shall be entirely and exclusively under the direction, supervision, and control of CONSULTANT. CONSULTANT hereby indemnifies and holds LOCAL AGENCY harmless from any and all claims that may be made against LOCAL AGENCY based upon any contention by any third party that an employer-employee relationship exists by reason of this AGREEMENT.

- G. Except as expressly authorized herein, CONSULTANT's obligations under this AGREEMENT are not assignable or transferable, and CONSULTANT shall not subcontract any work, without the prior written approval of the LOCAL AGENCY. However, claims for money due or which become due to CONSULTANT from LOCAL AGENCY under this AGREEMENT may be assigned to a financial institution or to a trustee in bankruptcy, without such approval. Notice of any assignment or transfer whether voluntary or involuntary shall be furnished promptly to the LOCAL AGENCY.
- H. CONSULTANT shall be as fully responsible to the LOCAL AGENCY for the negligent acts and omissions of its contractors and subcontractors or subconsultants, and of persons either directly or indirectly employed by them, in the same manner as persons directly employed by CONSULTANT.
- I. No alteration or variation of the terms of this AGREEMENT shall be valid, unless made in writing and signed by the parties authorized to bind the parties; and no oral understanding or agreement not incorporated herein, shall be binding on any of the parties hereto.
- J. The consideration to be paid to CONSULTANT as provided herein, shall be in compensation for all of CONSULTANT's expenses incurred in the performance hereof, including travel and per diem, unless otherwise expressly so provided.

ARTICLE II CONSULTANT'S REPORTS OR MEETINGS

- A. CONSULTANT shall submit progress reports at least once a month. The report should be sufficiently detailed for the LOCAL AGENCY's Contract Administrator to determine, if CONSULTANT is performing to expectations, or is on schedule; to provide communication of interim findings, and to sufficiently address any difficulties or special problems encountered, so remedies can be developed.
- B. CONSULTANT's Project Manager shall meet with LOCAL AGENCY's Contract Administrator, as needed, to discuss progress on the AGREEMENT.

ARTICLE III STATEMENT OF WORK

- A. CONSULTANT Services
[Detail based on the services to be furnished should be provided by CONSULTANT. Nature and extent should be verified in the negotiations to make precise statements to eliminate subsequent uncertainties and misunderstandings. Reference to the appropriate standards for design or other standards for work performance stipulated in CONSULTANT AGREEMENT should be included. Describe acceptance criteria, and if the responsible CONSULTANT/engineer shall sign all Plans, Specifications and Estimate (PS&E) and engineering data furnished under the AGREEMENT including registration number.]

Environmental documents are not considered complete until a Caltrans District Senior Environmental Planner signs the Categorical Exclusion, a Caltrans Deputy District Director signs the Finding of No Significant Impact, or the Caltrans District Director signs the Record of Decision (see [LAPM Chapter 6: Environmental Procedures](#), and the Standard Environmental Reference).]

- B. Right of Way
The Right of Way requirements are to be determined by CONSULTANT using the existing land survey. CONSULTANT to produce computations with metes and bounds descriptions that are and furnish any Right of Way parcel maps that are required.

C. Surveys

The CONSULTANT has the responsibility for performing preliminary or construction surveys as set forth in the RFP.

D. Subsurface Investigations

The CONSULTANT has responsibility for making subsurface investigations as set forth in the RFP. [If borings or other specialized services are to be made by others under the supervision of CONSULTANT, appropriate provisions are to be incorporated. Archaeological testing and data recovery guidance can be found in the Standard Environmental Reference.]

E. Local Agency Obligations

All data applicable to the project and in possession of LOCAL AGENCY, another agency, or government agency that are to be made available to CONSULTANT are referred to in the AGREEMENT. Any other assistance or services to be furnished to CONSULTANT are to be stated clearly.

F. Conferences, Site Visits, Inspection of Work

This AGREEMENT provides for conferences as needed, visits to the site, and inspection of the work by representatives of the LOCAL AGENCY, State, and/or FHWA. Costs incurred by CONSULTANT for meetings, subsequent to the initial meeting shall be included in the fee.

G. Checking Shop Drawings

[For AGREEMENTs requiring the preparation of construction drawings, make provision for checking shop drawings. Payment for checking shop drawings by CONSULTANT may be included in the AGREEMENT fee, or provision may be made for separate payment.]

H. CONSULTANT Services During Construction

The extent, if any of CONSULTANT's services during the course of construction as material testing, construction surveys. etc., are specified in the AGREEMENT together with the method of payment for such services.

I. Documentation and Schedules

AGREEMENTs where appropriate, shall provide that CONSULTANT document the results of the work to the satisfaction of LOCAL AGENCY, and if applicable, the State and FHWA. This may include preparation of progress and final reports, plans, specifications and estimates, or similar evidence of attainment of the AGREEMENT objectives.

J. Deliverables and Number of Copies

The number of copies or documents to be furnished, such as reports, brochures, sets of plans, specifications, or Right of Way parcel maps shall be specified. Provision may be made for payment for additional copies.

ARTICLE IV PERFORMANCE PERIOD

[A time must be set for beginning and ending the work under the AGREEMENT. The time allowed for performing the work is specified; it should be reasonable for the kind and amount of services contemplated; and it is written into the AGREEMENT. If it is desirable that Critical Path Method (CPM) networks, or other types of schedules be prepared by CONSULTANT, they should be identified and incorporated into the AGREEMENT. Refer to the RFP for direction on expected performance period.]

- A. This AGREEMENT shall go into effect on (DATE), contingent upon approval by LOCAL AGENCY, and CONSULTANT shall commence work after notification to proceed by LOCAL AGENCY'S Contract Administrator. The AGREEMENT shall end on (DATE), unless extended by AGREEMENT amendment.
- B. CONSULTANT is advised that any recommendation for AGREEMENT award is not binding on LOCAL AGENCY until the AGREEMENT is fully executed and approved by LOCAL AGENCY.

ARTICLE V ALLOWABLE COSTS AND PAYMENTS

- A. The method of payment for this AGREEMENT will be based on lump sum. The total lump sum price paid to CONSULTANT will include compensation for all work and deliverables, including travel and equipment described in Article III Statement of Work. No additional compensation will be paid to CONSULTANT, unless there is a change in the scope of the work or the scope of the project. In the instance of a change in the scope of work or scope of the project, adjustment to the total lump sum compensation will be negotiated between CONSULTANT and LOCAL AGENCY. Adjustment in the total lump sum compensation will not be effective until authorized by AGREEMENT amendment and approved by LOCAL AGENCY.
- B. Progress payments may be made monthly in arrears based on the percentage of work completed by CONSULTANT. If CONSULTANT fails to submit the required deliverable items according to the schedule set forth in Article III Statement of Work, LOCAL AGENCY shall have the right to delay payment or terminate this AGREEMENT in accordance with the provisions of Article VI Termination.
- C. CONSULTANT shall not commence performance of work or services until this AGREEMENT has been approved by LOCAL AGENCY and notification to proceed has been issued by LOCAL AGENCY'S Contract Administrator. No payment will be made prior to approval of any work, or for any work performed prior to approval of this AGREEMENT.
- D. CONSULTANT will be reimbursed within thirty (30) days upon receipt by LOCAL AGENCY'S Contract Administrator of itemized invoices in duplicate. Invoices shall be submitted no later than thirty (30) calendar days after the performance of work for which CONSULTANT is billing. Invoices shall detail the work performed on each milestone, on each project as applicable. Invoices shall follow the format stipulated for the approved Cost Proposal and shall reference this AGREEMENT number and project title. Final invoice must contain the final cost and all credits due LOCAL AGENCY that include any equipment purchased under the provisions of Article XI Equipment Purchase. The final invoice must be submitted within sixty (60) calendar days after completion of CONSULTANT'S work unless a later date is approved by the LOCAL AGENCY. Invoices shall be mailed to LOCAL AGENCY'S Contract Administrator at the following address:

City of Sand City
Attn: Vibeke Norgaard, City Manager
1 Pendergass Way, Sand City, CA 93955
- E. The total amount payable by LOCAL AGENCY shall not exceed \$(Amount).

ARTICLE VI TERMINATION

- A. This AGREEMENT may be terminated by LOCAL AGENCY, provided that LOCAL AGENCY gives not less than thirty (30) calendar days' written notice (delivered by certified mail, return receipt requested) of intent to terminate. Upon termination, LOCAL AGENCY shall be entitled to all work, including but not limited to, reports, investigations, appraisals, inventories, studies, analyses, drawings and data estimates performed to that date, whether completed or not.

- B. LOCAL AGENCY may temporarily suspend this AGREEMENT, at no additional cost to LOCAL AGENCY, provided that CONSULTANT is given written notice (delivered by certified mail, return receipt requested) of temporary suspension. If LOCAL AGENCY gives such notice of temporary suspension, CONSULTANT shall immediately suspend its activities under this AGREEMENT. A temporary suspension may be issued concurrent with the notice of termination.
- C. Notwithstanding any provisions of this AGREEMENT, CONSULTANT shall not be relieved of liability to LOCAL AGENCY for damages sustained by LOCAL AGENCY by virtue of any breach of this AGREEMENT by CONSULTANT, and LOCAL AGENCY may withhold any payments due to CONSULTANT until such time as the exact amount of damages, if any, due LOCAL AGENCY from CONSULTANT is determined.
- D. In the event of termination, CONSULTANT shall be compensated as provided for in this AGREEMENT. Upon termination, LOCAL AGENCY shall be entitled to all work, including but not limited to, reports, investigations, appraisals, inventories, studies, analyses, drawings and data estimates performed to that date, whether completed or not.

ARTICLE VII COST PRINCIPLES AND ADMINISTRATIVE REQUIREMENTS

- A. The CONSULTANT agrees that 48 CFR 31, Contract Cost Principles and Procedures, shall be used to determine the allowability of individual terms of cost.
- B. The CONSULTANT also agrees to comply with Federal procedures in accordance with 2 CFR 200, Uniform Administrative Requirements, Cost Principles, and Audit Requirements for Federal Awards.
- C. Any costs for which payment has been made to the CONSULTANT that are determined by subsequent audit to be unallowable under 48 CFR 31 or 2 CFR 200 are subject to repayment by the CONSULTANT to LOCAL AGENCY.
- D. When a CONSULTANT or Subconsultant is a Non-Profit Organization or an Institution of Higher Education, the Cost Principles for Title 2 CFR 200, Uniform Administrative Requirements, Cost Principles, and Audit Requirements for Federal Awards shall apply.

ARTICLE VIII RETENTION OF RECORD/AUDITS

For the purpose of determining compliance with Gov. Code § 8546.7, the CONSULTANT, Subconsultants, and LOCAL AGENCY shall maintain all books, documents, papers, accounting records, Independent CPA Audited Indirect Cost Rate workpapers, and other evidence pertaining to the performance of the AGREEMENT including, but not limited to, the costs of administering the AGREEMENT. All parties, including the CONSULTANT's Independent CPA, shall make such workpapers and materials available at their respective offices at all reasonable times during the AGREEMENT period and for three (3) years from the date of final payment under the AGREEMENT and records for real property and equipment acquired with federal funds must be retained for three (3) years after final disposition. LOCAL AGENCY, Caltrans Auditor, FHWA, or any duly authorized representative of the Federal government having jurisdiction under Federal laws or regulations (including the basis of Federal funding in whole or in part) shall have access to any books, records, and documents of the CONSULTANT, Subconsultants, and the CONSULTANT's Independent CPA, that are pertinent to the AGREEMENT for audits, examinations, workpaper review, excerpts, and transactions, and copies thereof shall be furnished if requested without limitation.

ARTICLE IX AUDIT REVIEW PROCEDURES

- A. Any dispute concerning a question of fact arising under an interim or post audit of this AGREEMENT that is not disposed of by AGREEMENT, shall be reviewed by LOCAL AGENCY'S Chief Financial Officer.
- B. Not later than thirty (30) calendar days after issuance of the final audit report, CONSULTANT may request a review by LOCAL AGENCY'S Chief Financial Officer of unresolved audit issues. The request for review will be submitted in writing.
- C. Neither the pendency of a dispute nor its consideration by LOCAL AGENCY will excuse CONSULTANT from full and timely performance, in accordance with the terms of this AGREEMENT.
- D. CONSULTANT and subconsultant AGREEMENTs, including cost proposals and Indirect Cost Rates (ICR), may be subject to audits or reviews such as, but not limited to, an AGREEMENT audit, an incurred cost audit, an ICR Audit, or a CPA ICR audit work paper review. If selected for audit or review, the AGREEMENT, cost proposal and ICR and related work papers, if applicable, will be reviewed to verify compliance with 48 CFR 31 and other related laws and regulations. In the instances of a CPA ICR audit work paper review it is CONSULTANT's responsibility to ensure federal, LOCAL AGENCY, or local government officials are allowed full access to the CPA's work papers including making copies as necessary. The AGREEMENT, cost proposal, and ICR shall be adjusted by CONSULTANT and approved by LOCAL AGENCY Contract Administrator to conform to the audit or review recommendations. CONSULTANT agrees that individual terms of costs identified in the audit report shall be incorporated into the AGREEMENT by this reference if directed by LOCAL AGENCY at its sole discretion. Refusal by CONSULTANT to incorporate audit or review recommendations, or to ensure that the federal, LOCAL AGENCY or local governments have access to CPA work papers, will be considered a breach of AGREEMENT terms and cause for termination of the AGREEMENT and disallowance of prior reimbursed costs.
- E. CONSULTANT's Cost Proposal may be subject to a CPA ICR Audit Work Paper Review and/or audit by the Independent Office of Audits and Investigations (IOAI). IOAI, at its sole discretion, may review and/or audit and approve the CPA ICR documentation. The Cost Proposal shall be adjusted by the CONSULTANT and approved by the LOCAL AGENCY Contract Administrator to conform to the Work Paper Review recommendations included in the management letter or audit recommendations included in the audit report. Refusal by the CONSULTANT to incorporate the Work Paper Review recommendations included in the management letter or audit recommendations included in the audit report will be considered a breach of the AGREEMENT terms and cause for termination of the AGREEMENT and disallowance of prior reimbursed costs.
 - 1. During IOAI's review of the ICR audit work papers created by the CONSULTANT's independent CPA, IOAI will work with the CPA and/or CONSULTANT toward a resolution of issues that arise during the review. Each party agrees to use its best efforts to resolve any audit disputes in a timely manner. If IOAI identifies significant issues during the review and is unable to issue a cognizant approval letter, LOCAL AGENCY will reimburse the CONSULTANT at an accepted ICR until a FAR (Federal Acquisition Regulation) compliant ICR (e.g. 48 CFR Part 31; GAGAS (Generally Accepted Auditing Standards); CAS (Cost Accounting Standards), if applicable; in accordance with procedures and guidelines of the American Association of State Highways and Transportation Officials (AASHTO) Audit Guide; and other applicable procedures and guidelines) is received and approved by IOAI.

Accepted rates will be as follows:

- a. If the proposed rate is less than one hundred fifty percent (150%) - the accepted rate reimbursed will be ninety percent (90%) of the proposed rate.
 - b. If the proposed rate is between one hundred fifty percent (150%) and two hundred percent (200%) - the accepted rate will be eighty-five percent (85%) of the proposed rate.
 - c. If the proposed rate is greater than two hundred percent (200%) - the accepted rate will be seventy-five percent (75%) of the proposed rate.
2. If IOAI is unable to issue a cognizant letter per paragraph E.1. above, IOAI may require CONSULTANT to submit a revised independent CPA-audited ICR and audit report within three (3) months of the effective date of the management letter. IOAI will then have up to six (6) months to review the CONSULTANT's and/or the independent CPA's revisions.
 3. If the CONSULTANT fails to comply with the provisions of this paragraph E, or if IOAI is still unable to issue a cognizant approval letter after the revised independent CPA audited ICR is submitted, overhead cost reimbursement will be limited to the accepted ICR that was established upon initial rejection of the ICR and set forth in paragraph E.1. above for all rendered services. In this event, this accepted ICR will become the actual and final ICR for reimbursement purposes under this AGREEMENT.
 4. CONSULTANT may submit to LOCAL AGENCY final invoice only when all of the following items have occurred: (1) IOAI accepts or adjusts the original or revised independent CPA audited ICR; (2) all work under this AGREEMENT has been completed to the satisfaction of LOCAL AGENCY; and, (3) IOAI has issued its final ICR review letter. The CONSULTANT MUST SUBMIT ITS FINAL INVOICE TO LOCAL AGENCY no later than sixty (60) calendar days after occurrence of the last of these items. The accepted ICR will apply to this AGREEMENT and all other agreements executed between LOCAL AGENCY and the CONSULTANT, either as a prime or subconsultant, with the same fiscal period ICR.

ARTICLE X SUBCONTRACTING

- A. Nothing contained in this AGREEMENT or otherwise, shall create any contractual relation between the LOCAL AGENCY and any Subconsultants, and no subagreement shall relieve the CONSULTANT of its responsibilities and obligations hereunder. The CONSULTANT agrees to be as fully responsible to the LOCAL AGENCY for the acts and omissions of its Subconsultants and of persons either directly or indirectly employed by any of them as it is for the acts and omissions of persons directly employed by the CONSULTANT. The CONSULTANT's obligation to pay its Subconsultants is an independent obligation from the LOCAL AGENCY's obligation to make payments to the CONSULTANT.
- B. The CONSULTANT shall perform the work contemplated with resources available within its own organization and no portion of the work shall be subcontracted without written authorization by the LOCAL AGENCY Contract Administrator, except that which is expressly identified in the CONSULTANT's approved Cost Proposal.
- C. Any subagreement entered into as a result of this AGREEMENT, shall contain all the provisions stipulated in this entire AGREEMENT to be applicable to Subconsultants unless otherwise noted.

D. Any substitution of Subconsultants must be approved in writing by the LOCAL AGENCY Contract Administrator in advance of assigning work to a substitute Subconsultant.

E. Prompt Progress Payment

CONSULTANT or subconsultant shall pay to any subconsultant, not later than fifteen (15) days after receipt of each progress payment, unless otherwise agreed to in writing, the respective amounts allowed CONSULTANT on account of the work performed by the subconsultants, to the extent of each subconsultant's interest therein. In the event that there is a good faith dispute over all or any portion of the amount due on a progress payment from CONSULTANT or subconsultant to a subconsultant, CONSULTANT or subconsultant may withhold no more than 150 percent of the disputed amount. Any violation of this requirement shall constitute a cause for disciplinary action and shall subject the licensee to a penalty, payable to the subconsultant, of 2 percent of the amount due per month for every month that payment is not made.

In any action for the collection of funds wrongfully withheld, the prevailing party shall be entitled to his or her attorney's fees and costs. The sanctions authorized under this requirement shall be separate from, and in addition to, all other remedies, either civil, administrative, or criminal.

F. Prompt Payment of Withheld Funds to Subconsultants

No retainage will be held by the LOCAL AGENCY from progress payments due to CONSULTANT. CONSULTANTS and subconsultants are prohibited from holding retainage from subconsultants. Any delay or postponement of payment may take place only for good cause and with the LOCAL AGENCY's prior written approval. Any violation of these provisions shall subject the violating CONSULTANT or subconsultant to the penalties, sanctions, and other remedies specified in Section 3321 of the California Civil Code. This requirement shall not be construed to limit or impair any contractual, administrative or judicial remedies, otherwise available to CONSULTANT or subconsultant in the event of a dispute involving late payment or nonpayment by CONSULTANT, deficient subconsultant performance and/or noncompliance by a subconsultant.

ARTICLE XI EQUIPMENT PURCHASE AND OTHER CAPITAL EXPENDITURES

- A. Prior authorization in writing by LOCAL AGENCY's Contract Administrator shall be required before CONSULTANT enters into any unbudgeted purchase order, or subcontract exceeding five thousand dollars (\$5,000) for supplies, equipment, or CONSULTANT services. CONSULTANT shall provide an evaluation of the necessity or desirability of incurring such costs.
- B. For purchase of any item, service, or consulting work not covered in CONSULTANT's approved Cost Proposal and exceeding five thousand dollars (\$5,000), with prior authorization by LOCAL AGENCY's Contract Administrator, three competitive quotations must be submitted with the request, or the absence of proposal must be adequately justified.
- C. Any equipment purchased with funds provided under the terms of this AGREEMENT is subject to the following:
 - 1. CONSULTANT shall maintain an inventory of all nonexpendable property. Nonexpendable property is defined as having a useful life of at least two years and an acquisition cost of five thousand dollars (\$5,000) or more. If the purchased equipment needs replacement and is sold or traded in, LOCAL AGENCY shall receive a proper refund or credit at the conclusion of the AGREEMENT, or if the AGREEMENT is terminated, CONSULTANT may either keep the equipment and credit LOCAL AGENCY in an amount equal to its fair market value, or sell such equipment at the best price obtainable at a public or private sale, in accordance with established LOCAL AGENCY procedures; and credit LOCAL AGENCY in an amount equal to the sales price. If CONSULTANT elects to keep the equipment, fair market value shall be determined at CONSULTANT's expense, on the basis of a competent independent appraisal of such equipment. Appraisals shall be obtained from an appraiser mutually agreeable to by LOCAL AGENCY and CONSULTANT, if it is determined to sell the equipment, the terms and conditions of such sale must be approved in advance by LOCAL AGENCY.
 - 2. Regulation 2 CFR 200 requires a credit to Federal funds when participating equipment with a fair market value greater than five thousand dollars (\$5,000) is credited to the project.

ARTICLE XII STATE PREVAILING WAGE RATES

- A. No CONSULTANT or Subconsultant may be awarded an AGREEMENT containing public work elements unless registered with the Department of Industrial Relations (DIR) pursuant to Labor Code §1725.5. Registration with DIR must be maintained throughout the entire term of this AGREEMENT, including any subsequent amendments.
- B. The CONSULTANT shall comply with all of the applicable provisions of the California Labor Code requiring the payment of prevailing wages. The General Prevailing Wage Rate Determinations applicable to work under this AGREEMENT are available and on file with the Department of Transportation's Regional/District Labor Compliance Officer (<https://dot.ca.gov/programs/construction/labor-compliance>). These wage rates are made a specific part of this AGREEMENT by reference pursuant to Labor Code §1773.2 and will be applicable to work performed at a construction project site. Prevailing wages will be applicable to all inspection work performed at LOCAL AGENCY construction sites, at LOCAL AGENCY facilities and at off-site locations that are set up by the construction contractor or one of its subcontractors solely and specifically to serve LOCAL AGENCY projects. Prevailing wage requirements do not apply to inspection work performed at the facilities of vendors and commercial materials suppliers that provide goods and services to the general public.
- C. General Prevailing Wage Rate Determinations applicable to this project may also be obtained from the Department of Industrial Relations website at <http://www.dir.ca.gov>.
- D. Payroll Records
 - 1. Each CONSULTANT and Subconsultant shall keep accurate certified payroll records and supporting documents as mandated by Labor Code §1776 and as defined in 8 CCR §16000 showing the name, address, social security number, work classification, straight time and overtime hours worked each day and week, and the actual per diem wages paid to each journeyman, apprentice, worker, or other employee employed by the CONSULTANT or Subconsultant in connection with the public work. Each payroll record shall contain or be verified by a written declaration that it is made under penalty of perjury, stating both of the following:
 - a. The information contained in the payroll record is true and correct.
 - b. The employer has complied with the requirements of Labor Code §1771, §1811, and §1815 for any work performed by his or her employees on the public works project.
 - 2. The payroll records enumerated under paragraph (1) above shall be certified as correct by the CONSULTANT under penalty of perjury. The payroll records and all supporting documents shall be made available for inspection and copying by LOCAL AGENCY representatives at all reasonable hours at the principal office of the CONSULTANT. The CONSULTANT shall provide copies of certified payrolls or permit inspection of its records as follows:
 - a. A certified copy of an employee's payroll record shall be made available for inspection or furnished to the employee or the employee's authorized representative on request.
 - b. A certified copy of all payroll records enumerated in paragraph (1) above, shall be made available for inspection or furnished upon request to a representative of LOCAL AGENCY, the Division of Labor Standards Enforcement and the Division of Apprenticeship Standards of the Department of Industrial Relations. Certified payrolls submitted to LOCAL AGENCY, the Division of Labor Standards Enforcement and the Division of Apprenticeship Standards shall not be altered or obliterated by the CONSULTANT.

- c. The public shall not be given access to certified payroll records by the CONSULTANT. The CONSULTANT is required to forward any requests for certified payrolls to the LOCAL AGENCY Contract Administrator by both email and regular mail on the business day following receipt of the request.
 - 3. Each CONSULTANT shall submit a certified copy of the records enumerated in paragraph(1) above, to the entity that requested the records within ten (10) calendar days after receipt of a written request.
 - 4. Any copy of records made available for inspection as copies and furnished upon request to the public or any public agency by LOCAL AGENCY shall be marked or obliterated in such a manner as to prevent disclosure of each individual's name, address, and social security number. The name and address of the CONSULTANT or Subconsultant performing the work shall not be marked or obliterated.
 - 5. The CONSULTANT shall inform LOCAL AGENCY of the location of the records enumerated under paragraph (1) above, including the street address, city and county, and shall, within five (5) working days, provide a notice of a change of location and address.
 - 6. The CONSULTANT or Subconsultant shall have ten (10) calendar days in which to comply subsequent to receipt of written notice requesting the records enumerated in paragraph (1) above. In the event the CONSULTANT or Subconsultant fails to comply within the ten (10) day period, he or she shall, as a penalty to LOCAL AGENCY, forfeit one hundred dollars (\$100) for each calendar day, or portion thereof, for each worker, until strict compliance is effectuated. Such penalties shall be withheld by LOCAL AGENCY from payments then due. CONSULTANT is not subject to a penalty assessment pursuant to this section due to the failure of a Subconsultant to comply with this section.
- E. When prevailing wage rates apply, the CONSULTANT is responsible for verifying compliance with certified payroll requirements. Invoice payment will not be made until the invoice is approved by the LOCAL AGENCY Contract Administrator.
- F. Penalty
- 1. The CONSULTANT and any of its Subconsultants shall comply with Labor Code §1774 and §1775. Pursuant to Labor Code §1775, the CONSULTANT and any Subconsultant shall forfeit to the LOCAL AGENCY a penalty of not more than two hundred dollars (\$200) for each calendar day, or portion thereof, for each worker paid less than the prevailing rates as determined by the Director of DIR for the work or craft in which the worker is employed for any public work done under the AGREEMENT by the CONSULTANT or by its Subconsultant in violation of the requirements of the Labor Code and in particular, Labor Code §§1770 to 1780, inclusive.
 - 2. The amount of this forfeiture shall be determined by the Labor Commissioner and shall be based on consideration of mistake, inadvertence, or neglect of the CONSULTANT or Subconsultant in failing to pay the correct rate of prevailing wages, or the previous record of the CONSULTANT or Subconsultant in meeting their respective prevailing wage obligations, or the willful failure by the CONSULTANT or Subconsultant to pay the correct rates of prevailing wages. A mistake, inadvertence, or neglect in failing to pay the correct rates of prevailing wages is not excusable if the CONSULTANT or Subconsultant had knowledge of the obligations under the Labor Code. The CONSULTANT is responsible for paying the appropriate rate, including any escalations that take place during the term of the AGREEMENT.

3. In addition to the penalty and pursuant to Labor Code §1775, the difference between the prevailing wage rates and the amount paid to each worker for each calendar day or portion thereof for which each worker was paid less than the prevailing wage rate shall be paid to each worker by the CONSULTANT or Subconsultant.
4. If a worker employed by a Subconsultant on a public works project is not paid the general prevailing per diem wages by the Subconsultant, the CONSULTANT of the project is not liable for the penalties described above unless the CONSULTANT had knowledge of that failure of the Subconsultant to pay the specified prevailing rate of wages to those workers or unless the CONSULTANT fails to comply with all of the following requirements:
 - a. The AGREEMENT executed between the CONSULTANT and the Subconsultant for the performance of work on public works projects shall include a copy of the requirements in Labor Code §§ 1771, 1775, 1776, 1777.5, 1813, and 1815.
 - b. The CONSULTANT shall monitor the payment of the specified general prevailing rate of per diem wages by the Subconsultant to the employees by periodic review of the certified payroll records of the Subconsultant.
 - c. Upon becoming aware of the Subconsultant's failure to pay the specified prevailing rate of wages to the Subconsultant's workers, the CONSULTANT shall diligently take corrective action to halt or rectify the failure, including but not limited to, retaining sufficient funds due the Subconsultant for work performed on the public works project.
 - d. Prior to making final payment to the Subconsultant for work performed on the public works project, the CONSULTANT shall obtain an affidavit signed under penalty of perjury from the Subconsultant that the Subconsultant had paid the specified general prevailing rate of per diem wages to the Subconsultant's employees on the public works project and any amounts due pursuant to Labor Code §1813.
5. Pursuant to Labor Code §1775, LOCAL AGENCY shall notify the CONSULTANT on a public works project within fifteen (15) calendar days of receipt of a complaint that a Subconsultant has failed to pay workers the general prevailing rate of per diem wages.
6. If LOCAL AGENCY determines that employees of a Subconsultant were not paid the general prevailing rate of per diem wages and if LOCAL AGENCY did not retain sufficient money under the AGREEMENT to pay those employees the balance of wages owed under the general prevailing rate of per diem wages, the CONSULTANT shall withhold an amount of moneys due the Subconsultant sufficient to pay those employees the general prevailing rate of per diem wages if requested by LOCAL AGENCY.

G. Hours of Labor

Eight (8) hours labor constitutes a legal day's work. The CONSULTANT shall forfeit, as a penalty to the LOCAL AGENCY, twenty-five dollars (\$25) for each worker employed in the execution of the AGREEMENT by the CONSULTANT or any of its Subconsultants for each calendar day during which such worker is required or permitted to work more than eight (8) hours in any one calendar day and forty (40) hours in any one calendar week in violation of the provisions of the Labor Code, and in particular §§1810 to 1815 thereof, inclusive, except that work performed by employees in excess of eight (8) hours per day, and forty (40) hours during any one week, shall be permitted upon compensation for all hours worked in excess of eight (8) hours per day and forty (40) hours in any week, at not less than one and one-half (1.5) times the basic rate of pay, as provided in §1815.

H. Employment of Apprentices

1. Where either the prime AGREEMENT or the subagreement exceeds thirty thousand dollars (\$30,000), the CONSULTANT and any subconsultants under him or her shall comply with all applicable requirements of Labor Code §§ 1777.5, 1777.6 and 1777.7 in the employment of apprentices.
2. CONSULTANTS and subconsultants are required to comply with all Labor Code requirements regarding the employment of apprentices, including mandatory ratios of journey level to apprentice workers. Prior to commencement of work, CONSULTANT and subconsultants are advised to contact the DIR Division of Apprenticeship Standards website at <https://www.dir.ca.gov/das/>, for additional information regarding the employment of apprentices and for the specific journey-to- apprentice ratios for the AGREEMENT work. The CONSULTANT is responsible for all subconsultants' compliance with these requirements. Penalties are specified in Labor Code §1777.7.

ARTICLE XIII CONFLICT OF INTEREST

- A. During the term of this AGREEMENT, the CONSULTANT shall disclose any financial, business, or other relationship with LOCAL AGENCY that may have an impact upon the outcome of this AGREEMENT or any ensuing LOCAL AGENCY construction project. The CONSULTANT shall also list current clients who may have a financial interest in the outcome of this AGREEMENT or any ensuing LOCAL AGENCY construction project which will follow.
- B. CONSULTANT certifies that it has disclosed to LOCAL AGENCY any actual, apparent, or potential conflicts of interest that may exist relative to the services to be provided pursuant to this AGREEMENT. CONSULTANT agrees to advise LOCAL AGENCY of any actual, apparent or potential conflicts of interest that may develop subsequent to the date of execution of this AGREEMENT. CONSULTANT further agrees to complete any statements of economic interest if required by either LOCAL AGENCY ordinance or State law.
- C. The CONSULTANT hereby certifies that it does not now have, nor shall it acquire any financial or business interest that would conflict with the performance of services under this AGREEMENT.
- D. The CONSULTANT hereby certifies that the CONSULTANT or subconsultant and any firm affiliated with the CONSULTANT or subconsultant that bids on any construction contract or on any Agreement to provide construction inspection for any construction project resulting from this AGREEMENT, has established necessary controls to ensure a conflict of interest does not exist. An affiliated firm is one, which is subject to the control of the same persons, through joint ownership or otherwise.

ARTICLE XIV REBATES, KICKBACKS OR OTHER UNLAWFUL CONSIDERATION

The CONSULTANT warrants that this AGREEMENT was not obtained or secured through rebates, kickbacks or other unlawful consideration either promised or paid to any LOCAL AGENCY employee. For breach or violation of this warranty, LOCAL AGENCY shall have the right, in its discretion, to terminate this AGREEMENT without liability, to pay only for the value of the work actually performed, or to deduct from this AGREEMENT price or otherwise recover the full amount of such rebate, kickback or other unlawful consideration.

ARTICLE XV PROHIBITION OF EXPENDING LOCAL AGENCY, STATE, OR FEDERAL FUNDS FOR LOBBYING

[Include this article in all AGREEMENTs where federal funding will exceed \$100,000. If less than \$100,000 in federal funds will be expended on the AGREEMENT; delete this article and re-number the subsequent articles.]

- A. The CONSULTANT certifies, to the best of his or her knowledge and belief, that:
1. No State, Federal, or LOCAL AGENCY appropriated funds have been paid or will be paid, by or on behalf of the CONSULTANT, to any person for influencing or attempting to influence an officer or employee of any local, State, or Federal agency, a Member of the State Legislature or United States Congress, an officer or employee of the Legislature or Congress, or any employee of a Member of the Legislature or Congress in connection with the awarding or making of this AGREEMENT, or with the extension, continuation, renewal, amendment, or modification of this AGREEMENT.
 2. If any funds other than Federal appropriated funds have been paid or will be paid to any person for influencing or attempting to influence an officer or employee of any agency, a Member of Congress, an officer or employee of Congress, or an employee of a member of Congress in connection with this AGREEMENT, the CONSULTANT shall complete and submit Standard Form-LLL, "Disclosure Form to Report Lobbying," in accordance with its instructions.
- B. This certification is a material representation of fact upon which reliance was placed when this transaction was made or entered into. Submission of this certification is a prerequisite for making or entering into this transaction imposed by 31 U.S.C. §1352. Any person who fails to file the required certification shall be subject to a civil penalty of not less than ten thousand dollars (\$10,000) and not more than one hundred thousand dollars (\$100,000) for each such failure.
- C. The CONSULTANT also agrees by signing this document that he or she shall require that the language of this certification be included in all lower tier subagreements, which exceed one hundred thousand dollars (\$100,000), and that all such subrecipients shall certify and disclose accordingly.

ARTICLE XVI NON-DISCRIMINATION CLAUSE AND STATEMENT OF COMPLIANCE

- A. The CONSULTANT's signature affixed herein and dated shall constitute a certification under penalty of perjury under the laws of the State of California that the CONSULTANT has, unless exempt, complied with the nondiscrimination program requirements of Gov. Code §12990 and 2 CCR §11102.
- B. During the performance of this AGREEMENT, CONSULTANT and its subconsultants shall not deny the AGREEMENT's benefits to any person on the basis of race, religious creed, color, national origin, ancestry, physical disability, mental disability, medical condition, genetic information, marital status, sex, gender, gender identity, gender expression, age, sexual orientation, or military and veteran status, nor shall they unlawfully discriminate, harass, or allow harassment against any employee or applicant for employment because of race, religious creed, color, national origin, ancestry, physical disability, mental disability, medical condition, genetic information, marital status, sex, gender, gender identity, gender expression, age, sexual orientation, or military and veteran status. CONSULTANT and subconsultants shall ensure that the evaluation and treatment of their employees and applicants for employment are free from such discrimination and harassment.

- C. CONSULTANT and subconsultants shall comply with the provisions of the Fair Employment and Housing Act (Gov. Code §12990 et seq.), the applicable regulations promulgated there under (2 CCR §11000 et seq.), the provisions of Gov. Code §§11135-11139.5, and the regulations or standards adopted by LOCAL AGENCY to implement such article. The applicable regulations of the Fair Employment and Housing Commission implementing Gov. Code §12990 (a-f), set forth 2CCR §§8100-8504, are incorporated into this AGREEMENT by reference and made a part hereof as if set forth in full.
- D. CONSULTANT shall permit access by representatives of the Department of Fair Employment and Housing and the LOCAL AGENCY upon reasonable notice at any time during the normal business hours, but in no case less than twenty-four (24) hours' notice, to such of its books, records, accounts, and all other sources of information and its facilities as said Department or LOCAL AGENCY shall require to ascertain compliance with this clause.
- E. CONSULTANT and its subconsultants shall give written notice of their obligations under this clause to labor organizations with which they have a collective bargaining or other Agreement.
- F. CONSULTANT shall include the nondiscrimination and compliance provisions of this clause in all subcontracts to perform work under this AGREEMENT.
- G. The CONSULTANT, with regard to the work performed under this AGREEMENT, shall act in accordance with Title VI of the Civil Rights Act of 1964 (42 U.S.C. §2000d et seq.). Title VI provides that the recipients of federal assistance will implement and maintain a policy of nondiscrimination in which no person in the United States shall, on the basis of race, color, national origin, religion, sex, age, disability, be excluded from participation in, denied the benefits of or subject to discrimination under any program or activity by the recipients of federal assistance or their assignees and successors in interest.
- H. The CONSULTANT shall comply with regulations relative to non-discrimination in federally-assisted programs of the U.S. Department of Transportation (49 CFR 21 - Effectuation of Title VI of the Civil Rights Act of 1964). Specifically, the CONSULTANT shall not participate either directly or indirectly in the discrimination prohibited by 49 CFR §21.5, including employment practices and the selection and retention of Subconsultants.
- I. CONSULTANT, subrecipient or subconsultant will never exclude any person from participation in, deny any person the benefits of, or otherwise discriminate against anyone in connection with the award and performance of any contract covered by 49 CFR 26 on the basis of race, color, sex, or national origin.

ARTICLE XVII DEBARMENT AND SUSPENSION CERTIFICATION

- A. The CONSULTANT's signature affixed herein shall constitute a certification under penalty of perjury under the laws of the State of California, that the CONSULTANT or any person associated therewith in the capacity of owner, partner, director, officer or manager:
 1. Is not currently under suspension, debarment, voluntary exclusion, or determination of ineligibility by any federal agency;
 2. Has not been suspended, debarred, voluntarily excluded, or determined ineligible by any federal agency within the past three (3) years;

3. Does not have a proposed debarment pending; and
 4. Has not been indicted, convicted, or had a civil judgment rendered against it by a court of competent jurisdiction in any matter involving fraud or official misconduct within the past three (3) years.
- B. Any exceptions to this certification must be disclosed to LOCAL AGENCY. Exceptions will not necessarily result in denial of recommendation for award, but will be considered in determining responsibility. Disclosures must indicate the party to whom the exceptions apply, the initiating agency, and the dates of agency action.
- C. Exceptions to the Federal Government excluded parties (<https://sam.gov/content/home>) maintained by the U.S. General Services Administration are to be determined by FHWA.

ARTICLE XVIII DISADVANTAGED BUSINESS ENTERPRISES (DBE)

CONSULTANT, Under 49 CFR 26.13(b):

CONSULTANT or subconsultant shall not discriminate on the basis of race, color, national origin, or sex in the performance of this contract. CONSULTANT shall carry out applicable requirements of 49 CFR 26 in the award and administration of federal-aid contracts.

Failure by the CONSULTANT to carry out these requirements is a material breach of this contract, which may result in the termination of this contract or such other remedy as the recipient deems appropriate, which may include, but is not limited to:

- (1) Withholding monthly progress payments;
- (2) Assessing sanctions;
- (3) Disqualifying CONSULTANT from future proposing as non-responsible

ARTICLE XIX INSURANCE

- A. Prior to commencement of the work described herein, CONSULTANT shall furnish LOCAL AGENCY a Certificate of Insurance stating that there is general comprehensive liability insurance presently in effect for CONSULTANT with a combined single limit (CSL) of not less than one million dollars (\$1,000,000) per occurrence.
- B. The Certificate of Insurance will provide:
1. That the insurer will not cancel the insured's coverage without thirty (30) calendar days prior written notice to LOCAL AGENCY.
 2. That LOCAL AGENCY, its officers, agents, employees, and servants are included as additional insureds, but only insofar as the operations under this AGREEMENT are concerned.
 3. That LOCAL AGENCY will not be responsible for any premiums or assessments on the policy.

- C. CONSULTANT agrees that the bodily injury liability insurance herein provided for, shall be in effect at all times during the term of this AGREEMENT. In the event said insurance coverage expires at any time or times during the term of this AGREEMENT, CONSULTANT agrees to provide at least thirty (30) calendar days prior notice to said expiration date; and a new Certificate of Insurance evidencing insurance coverage as provided for herein, for not less than either the remainder of the term of the AGREEMENT, or for a period of not less than one (1) year. New Certificates of Insurance are subject to the approval of LOCAL AGENCY. In the event CONSULTANT fails to keep in effect at all times insurance coverage as herein provided, LOCAL AGENCY may, in addition to any other remedies it may have, terminate this AGREEMENT upon occurrence of such event.

ARTICLE XX FUNDING REQUIREMENTS

- A. It is mutually understood between the parties that this AGREEMENT may have been written before ascertaining the availability of funds or appropriation of funds, for the mutual benefit of both parties, in order to avoid program and fiscal delays that would occur if the AGREEMENT were executed after that determination was made.
- B. This AGREEMENT is valid and enforceable only if sufficient funds are made available to LOCAL AGENCY for the purpose of this AGREEMENT. In addition, this AGREEMENT is subject to any additional restrictions, limitations, conditions, or any statute enacted by the Congress, State Legislature, or LOCAL AGENCY governing board that may affect the provisions, terms, or funding of this AGREEMENT in any manner.
- C. It is mutually agreed that if sufficient funds are not appropriated, this AGREEMENT may be amended to reflect any reduction in funds.
- D. LOCAL AGENCY has the option to terminate the AGREEMENT pursuant to Article VI Termination, or by mutual agreement to amend the AGREEMENT to reflect any reduction of funds.

ARTICLE XXI CHANGE IN TERMS

- A. This AGREEMENT may be amended or modified only by mutual written agreement of the parties.
- B. CONSULTANT shall only commence work covered by an amendment after the amendment is executed and notification to proceed has been provided by LOCAL AGENCY's Contract Administrator.
- C. There shall be no change in CONSULTANT's Project Manager or members of the project team, as listed in the approved Cost Proposal, which is a part of this AGREEMENT without prior written approval by LOCAL AGENCY's Contract Administrator.

ARTICLE XXII CONTINGENT FEE

CONSULTANT warrants, by execution of this AGREEMENT that no person or selling agency has been employed, or retained, to solicit or secure this AGREEMENT upon an agreement or understanding, for a commission, percentage, brokerage, or contingent fee, excepting bona fide employees, or bona fide established commercial or selling agencies maintained by CONSULTANT for the purpose of securing

business. For breach or violation of this warranty, LOCAL AGENCY has the right to annul this AGREEMENT without liability; pay only for the value of the work actually performed, or in its discretion to deduct from the AGREEMENT price or consideration, or otherwise recover the full amount of such commission, percentage, brokerage, or contingent fee.

ARTICLE XXIII DISPUTES

Prior to either party commencing any legal action under this AGREEMENT, the parties agree to try in good faith, to settle any dispute amicably between them. If a dispute has not been settled after forty-five

(45) days of good-faith negotiations and as may be otherwise provided herein, then either party may commence legal action against the other.

- A. Any dispute, other than audit, concerning a question of fact arising under this AGREEMENT that is not disposed of by agreement shall be decided by a committee consisting of LOCAL AGENCY's Contract Administrator and City Manager, who may consider written or verbal information submitted by CONSULTANT.
- B. Not later than thirty (30) calendar days after completion of all deliverables necessary to complete the plans, specifications and estimate, CONSULTANT may request review by LOCAL AGENCY Governing Board of unresolved claims or disputes, other than audit. The request for review will be submitted in writing.
- C. Neither the pendency of a dispute, nor its consideration by the committee will excuse CONSULTANT from full and timely performance in accordance with the terms of this AGREEMENT.

ARTICLE XXIV INSPECTION OF WORK

CONSULTANT and any subconsultant shall permit LOCAL AGENCY, the State, and the FHWA if federal participating funds are used in this AGREEMENT; to review and inspect the project activities and files at all reasonable times during the performance period of this AGREEMENT.

ARTICLE XXV SAFETY

- A. CONSULTANT shall comply with OSHA regulations applicable to CONSULTANT regarding necessary safety equipment or procedures. CONSULTANT shall comply with safety instructions issued by LOCAL AGENCY Safety Officer and other LOCAL AGENCY representatives. CONSULTANT personnel shall wear hard hats and safety vests at all times while working on the construction project site.
- B. Pursuant to the authority contained in Vehicle Code §591, LOCAL AGENCY has determined that such areas are within the limits of the project and are open to public traffic. CONSULTANT shall comply with all of the requirements set forth in Divisions 11, 12, 13, 14, and 15 of the Vehicle Code. CONSULTANT shall take all reasonably necessary precautions for safe operation of its vehicles and the protection of the traveling public from injury and damage from such vehicles.

- C. Any subcontract entered into as a result of this contract, shall contain all of the provisions of this Article.

ARTICLE XXVI OWNERSHIP OF DATA

- A. It is mutually agreed that all materials prepared by CONSULTANT under this AGREEMENT shall become the property of LOCAL AGENCY, and CONSULTANT shall have no property right therein whatsoever. Immediately upon termination, LOCAL AGENCY shall be entitled to, and CONSULTANT shall deliver to LOCAL AGENCY, reports, investigations, appraisals, inventories, studies, analyses, drawings and data estimates performed to that date, whether completed or not, and other such materials as may have been prepared or accumulated to date by CONSULTANT in performing this AGREEMENT which is not CONSULTANT's privileged information, as defined by law, or CONSULTANT's personnel information, along with all other property belonging exclusively to LOCAL AGENCY which is in CONSULTANT's possession. Publication of the information derived from work performed or data obtained in connection with services rendered under this AGREEMENT must be approved in writing by LOCAL AGENCY.
- B. Additionally, it is agreed that the Parties intend this to be an AGREEMENT for services and each considers the products and results of the services to be rendered by CONSULTANT hereunder to be work made for hire. CONSULTANT acknowledges and agrees that the work (and all rights therein, including, without limitation, copyright) belongs to and shall be the sole and exclusive property of LOCAL AGENCY without restriction or limitation upon its use or dissemination by City.
- C. Nothing herein shall constitute or be construed to be any representation by CONSULTANT that the work product is suitable in any way for any other project except the one detailed in this Contract. Any reuse by LOCAL AGENCY for another project or project location shall be at LOCAL AGENCY's sole risk.
- D. Applicable patent rights provisions regarding rights to inventions shall be included in the contracts as appropriate (48 CFR 27 Subpart 27.3 - Patent Rights under Government Contracts for federal-aid contracts).
- E. LOCAL AGENCY may permit copyrighting reports or other agreement products. If copyrights are permitted; the AGREEMENT shall provide that the FHWA shall have the royalty-free nonexclusive and irrevocable right to reproduce, publish, or otherwise use; and to authorize others to use, the work for government purposes.

ARTICLE XXVII CLAIMS FILED BY LOCAL AGENCY'S CONSTRUCTION CONTRACTOR

- A. If claims are filed by LOCAL AGENCY's construction contractor relating to work performed by CONSULTANT's personnel, and additional information or assistance from CONSULTANT's personnel is required in order to evaluate or defend against such claims; CONSULTANT agrees to make its personnel available for consultation with LOCAL AGENCY'S construction contract administration and legal staff and for testimony, if necessary, at depositions and at trial or arbitration proceedings.

- B. CONSULTANT's personnel that LOCAL AGENCY considers essential to assist in defending against construction contractor claims will be made available on reasonable notice from LOCAL AGENCY. Consultation or testimony will be reimbursed at the same rates, including travel costs that are being paid for CONSULTANT's personnel services under this AGREEMENT.
- C. Services of CONSULTANT's personnel in connection with LOCAL AGENCY's construction contractor claims will be performed pursuant to a written contract amendment, if necessary, extending the termination date of this AGREEMENT in order to resolve the construction claims.

ARTICLE XXVIII CONFIDENTIALITY OF DATA

- A. All financial, statistical, personal, technical, or other data and information relative to LOCAL AGENCY's operations, which are designated confidential by LOCAL AGENCY and made available to CONSULTANT in order to carry out this AGREEMENT, shall be protected by CONSULTANT from unauthorized use and disclosure.
- B. Permission to disclose information on one occasion, or public hearing held by LOCAL AGENCY relating to the AGREEMENT, shall not authorize CONSULTANT to further disclose such information, or disseminate the same on any other occasion.
- C. CONSULTANT shall not comment publicly to the press or any other media regarding the AGREEMENT or LOCAL AGENCY's actions on the same, except to LOCAL AGENCY's staff, CONSULTANT's own personnel involved in the performance of this AGREEMENT, at public hearings, or in response to questions from a Legislative committee.
- D. CONSULTANT shall not issue any news release or public relations item of any nature, whatsoever, regarding work performed or to be performed under this AGREEMENT without prior review of the contents thereof by LOCAL AGENCY, and receipt of LOCAL AGENCY'S written permission.
- E. Any subcontract entered into as a result of this contract shall contain all of the provisions of this Article.
- F. All information related to the construction estimate is confidential, and shall not be disclosed by CONSULTANT to any entity, other than LOCAL AGENCY, Caltrans, and/or FHWA. All of the materials prepared or assembled by CONSULTANT pursuant to performance of this Contract are confidential and CONSULTANT agrees that they shall not be made available to any individual or organization without the prior written approval of LOCAL AGENCY or except by court order. If CONSULTANT or any of its officers, employees, or subcontractors does voluntarily provide information in violation of this Contract, LOCAL AGENCY has the right to reimbursement and indemnity from CONSULTANT for any damages caused by CONSULTANT releasing the information, including, but not limited to, LOCAL AGENCY's attorney's fees and disbursements, including without limitation experts' fees and disbursements.

ARTICLE XXIX NATIONAL LABOR RELATIONS BOARD CERTIFICATION

In accordance with Public Contract Code §10296, CONSULTANT hereby states under penalty of perjury that no more than one final unappealable finding of contempt of court by a federal court has been issued against CONSULTANT within the immediately preceding two-year period, because of CONSULTANT's failure to comply with an order of a federal court that orders CONSULTANT to comply with an order of the National Labor Relations Board.

ARTICLE XXX EVALUATION OF CONSULTANT

CONSULTANT's performance will be evaluated by LOCAL AGENCY. A copy of the evaluation will be sent to CONSULTANT for comments. The evaluation together with the comments shall be retained as part of the AGREEMENT record.

ARTICLE XXXII TITLE VI ASSURANCES

APPENDICES A - E of the TITLE VI ASSURANCES

The U.S. Department of Transportation Order No.1050.2A requires all federal-aid Department of Transportation contracts between an agency and a consultant to contain Appendices A and E of the Title VI Assurances. In addition, the consultant must include the Title VI Assurances Appendices A and E in all subcontracts to perform work under the contract.

APPENDIX A

During the performance of this Agreement, the contractor, for itself, its assignees and successors in interest (hereinafter collectively referred to as CONSULTANT) agrees as follows:

- a. Compliance with Regulations: CONSULTANT shall comply with the regulations relative to nondiscrimination in federally assisted programs of the Department of Transportation, Title 49, Code of Federal Regulations, Part 21, as they may be amended from time to time, (hereinafter referred to as the REGULATIONS), which are herein incorporated by reference and made a part of this agreement.
- b. Nondiscrimination: CONSULTANT, with regard to the work performed by it during the AGREEMENT, shall not discriminate on the grounds of race, color, sex, national origin, religion, age, or disability in the selection and retention of sub-applicants, including procurements of materials and leases of equipment. CONSULTANT shall not participate either directly or indirectly in the discrimination prohibited by Section 21.5 of the Regulations, including employment practices when the agreement covers a program set forth in Appendix B of the Regulations.
- c. Solicitations for Sub-agreements, Including Procurements of Materials and Equipment: In all solicitations either by competitive bidding or negotiation made by CONSULTANT for work to be performed under a Sub-agreement, including procurements of materials or leases of equipment, each potential sub-applicant or supplier shall be notified by CONSULTANT of the CONSULTANT'S obligations under this Agreement and the Regulations relative to nondiscrimination on the grounds of race, color, or national origin.
- d. Information and Reports: CONSULTANT shall provide all information and reports required by the Regulations, or directives issued pursuant thereto, and shall permit access to its books, records, accounts, other sources of information, and its facilities as may be determined by the recipient or FHWA to be pertinent to ascertain compliance with such Regulations or directives. Where any information required of CONSULTANT is in the exclusive possession of another who fails or refuses to furnish this information, CONSULTANT shall so certify to the recipient or FHWA as appropriate, and shall set forth what efforts CONSULTANT has made to obtain the information.

- e. Sanctions for Noncompliance: In the event of CONSULTANT’s noncompliance with the nondiscrimination provisions of this agreement, the recipient shall impose such agreement sanctions as it or the FHWA may determine to be appropriate, including, but not limited to:
- i. withholding of payments to CONSULTANT under the Agreement within a reasonable period of time, not to exceed 90 days; and/or
 - ii. cancellation, termination or suspension of the Agreement, in whole or in part.
- f. Incorporation of Provisions: CONSULTANT shall include the provisions of paragraphs (1) through (6) in every sub-agreement, including procurements of materials and leases of equipment, unless exempt by the Regulations, or directives issued pursuant thereto.

CONSULTANT shall take such action with respect to any sub-agreement or procurement as the recipient or FHWA may direct as a means of enforcing such provisions including sanctions for noncompliance, provided, however, that, in the event CONSULTANT becomes involved in, or is threatened with, litigation with a sub-applicant or supplier as a result of such direction, CONSULTANT may request the recipient enter into such litigation to protect the interests of the State, and, in addition, CONSULTANT may request the United States to enter into such litigation to protect the interests of the United States.

APPENDIX B INTENTIONALLY OMITTED

APPENDIX C INTENTIONALLY OMITTED

APPENDIX D INTENTIONALLY OMITTED

APPENDIX E

During the performance of this contract, the CONSULTANT, for itself, its assignees, and successors in interest (hereinafter referred to as the “CONSULTANT”) agrees to comply with the following non-discrimination statutes and authorities, including, but not limited to:

Pertinent Non-Discrimination Authorities:

- Title VI of the Civil Rights Act of 1964 (42 U.S.C. § 2000d et seq., 78 stat. 252), prohibits discrimination on the basis of race, color, national origin); and 49 CFR Part 21.
- The Uniform Relocation Assistance and Real Property Acquisition Policies Act of 1970, (42 U.S.C. § 4601), (prohibits unfair treatment of persons displaced or whose property has been acquired because of Federal or Federal-aid programs and projects);
- Federal-Aid Highway Act of 1973, (23 U.S.C. § 324 et seq.), prohibits discrimination on the basis of sex;
- Section 504 of the Rehabilitation Act of 1973, (29 U.S.C. § 794 et seq.), as amended, (prohibits discrimination on the basis of disability); and 49 CR Part 27;

- The Age Discrimination Act of 1975, as amended, (42 U.S.C. § 6101 et seq.), prohibits discrimination on the basis of age);
- Airport and Airway Improvement Act of 1982, (49 U.S.C. § 471, Section 47123), as amended, (prohibits discrimination based on race, creed, color, national origin, or sex);
- The Civil Rights Restoration Act of 1987, (PL 100-209), (Broadened the scope, coverage and applicability of Title VI of the Civil Rights Act of 1964, The Age Discrimination Act of 1975 and Section 504 of the Rehabilitation Act of 1973, by expanding the definition of the terms “programs or activities” to include all of the programs or activities of the Federal-aid recipients, sub-recipients and contractors, whether such programs or activities are Federally funded or not);
- Titles II and III of the Americans with Disabilities Act, which prohibit discrimination on the basis of disability in the operation of public entities, public and private transportation systems, places of public accommodation, and certain testing entities (42 U.S.C. §§ 12131 – 12189) as implemented by Department of Transportation regulations 49 C.F.R. parts 37 and 38;
- The Federal Aviation Administration’s Non-discrimination statute (49 U.S.C. § 47123) (prohibits discrimination on the basis of race, color, national origin, and sex);
- Executive Order 12898, Federal Actions to Address Environmental Justice in Minority Populations and Low-Income Populations, which ensures discrimination against minority populations by discouraging programs, policies, and activities with disproportionately high and adverse human health or environmental effects on minority and low-income populations;
- Executive Order 13166, Improving Access to Services for Persons with Limited English Proficiency, and resulting agency guidance, national origin discrimination includes discrimination because of Limited English Proficiency (LEP). To ensure compliance with Title VI, you must take reasonable steps to ensure that LEP persons have meaningful access to your programs (70 Fed. Reg. at 74087 to 74100);
- Title IX of the Education Amendments of 1972, as amended, which prohibits you from discriminating because of sex in education programs or activities (20 U.S.C. 1681 et seq).

ARTICLE XXXIII SUPPLEMENTAL LOCAL TERMS

The following provisions are supplemental to and incorporated into this AGREEMENT between the City of Sand City, a California municipal corporation, hereinafter referred to as LOCAL AGENCY, and CONSULTANT. In the event of any conflict between these Supplemental Local Terms and the federal or state requirements contained elsewhere in this AGREEMENT, the federal or state requirements shall control.

A. Governing Law and Venue

This AGREEMENT shall be governed by and construed in accordance with the laws of the State of California. Venue for any action arising out of or related to this AGREEMENT shall be in the Superior Court of the State of California, County of Monterey.

B. Mediation

Prior to initiating litigation, the parties agree to participate in good faith in non binding mediation. The mediator shall be mutually agreed upon by the parties. Each party shall bear its own costs of mediation and shall share equally in the cost of the mediator.

C. Business License

CONSULTANT shall maintain a valid City of Sand City business license, if required by the Sand City Municipal Code, for the duration of this AGREEMENT.

D. Invoicing Requirements

In addition to the requirements set forth elsewhere in this AGREEMENT, CONSULTANT invoices shall:

1. Reference the AGREEMENT number and task order number, if applicable.
2. Identify the billing period covered.
3. Itemize labor hours by classification and task.
4. Include supporting documentation as required by LOCAL AGENCY to substantiate costs.

Invoices shall be submitted to the LOCAL AGENCY Contract Administrator or designee.

E. Professional Liability Insurance

In addition to the insurance requirements set forth in this AGREEMENT, CONSULTANT shall maintain professional liability insurance in an amount not less than one million dollars per claim and in the aggregate. Coverage shall be maintained for a period of not less than three years following completion of services under this AGREEMENT.

F. Independent Contractor

CONSULTANT is and shall at all times remain an independent contractor. LOCAL AGENCY shall have no right of control over the manner in which CONSULTANT performs the services, except as expressly set forth in this AGREEMENT.

G. Assignment

CONSULTANT shall not assign, transfer, or subcontract this AGREEMENT or any portion thereof without prior written approval of the LOCAL AGENCY Contract Administrator, except as otherwise permitted under applicable federal and state regulations.

H. Authority to Execute

The individual signing this AGREEMENT on behalf of CONSULTANT represents and warrants that he or she is duly authorized to execute and bind CONSULTANT to the terms and conditions of this AGREEMENT.

I. Public Records

CONSULTANT acknowledges that LOCAL AGENCY is subject to the California Public Records Act. All documents submitted by CONSULTANT in connection with this AGREEMENT may be subject to public disclosure unless exempt by law.

ARTICLE XXXIV NOTIFICATION

All notices hereunder and communications regarding interpretation of the terms of this AGREEMENT and changes thereto, shall be effected by the mailing thereof by registered or certified mail, return receipt requested, postage prepaid, and addressed as follows:

CONSULTANT: _____
(CONSULTANT)

_____(NAME)_____,Project Manager

_____(ADDRESS)_____

LOCAL AGENCY:

_____(LOCAL AGENCY)_____

_____(NAME)_____, Contract Administrator

_____(ADDRESS)_____

ARTICLE XXXV CONTRACT

The two parties to this AGREEMENT, who are the before named CONSULTANT and the before named LOCAL AGENCY, hereby agree that this AGREEMENT constitutes the entire AGREEMENT which is made and concluded in duplicate between the two parties. Both of these parties for and in consideration of the payments to be made, conditions mentioned, and work to be performed; each agree to diligently perform in accordance with the terms and conditions of this AGREEMENT as evidenced by the signatures below.

ARTICLE XXXV SIGNATURES

CONSULTANT

By: _____
(Signature)

(Typed Name)

(Title)

Date: _____

CITY OF SAND CITY

Vibeke Norgaard, City Manager

Date: _____

ATTEST:

Kerry Lindstrom, City Clerk

Audrey Cray, Risk Manager

APPROVED AS TO FORM:

By: _____
Adam Lindgren, City Attorney

Attachments:	Exhibit A	Consultant's Proposal
	Exhibit B	Fee Schedule
	Exhibit C	Insurance Requirements

EXHIBIT A

CONSULTANT'S PROPOSAL

EXHIBIT B

FEE SCHEDULE

EXHIBIT C

INSURANCE REQUIREMENTS

Without limiting CONSULTANT's indemnification of CITY, and prior to commencement of Work, CONSULTANT shall obtain, provide and maintain at its own expense during the term of this AGREEMENT, policies of insurance of the type and amounts described below and, in a form, satisfactory to CITY.

General liability insurance. CONSULTANT shall maintain commercial general liability insurance with coverage at least as broad as Insurance Services Office form CG 00 01, in an amount not less than \$1,000,000 per occurrence, \$2,000,000 general aggregate, for bodily injury, personal injury, and property damage. The policy must include contractual liability that has not been amended. Any endorsement restricting standard ISO "insured contract" language will not be accepted.

Automobile liability insurance. CONSULTANT shall maintain automobile insurance at least as broad as Insurance Services Office form CA 00 01 covering bodily injury and property damage for all activities of the Consultant arising out of or in connection with Work to be performed under this AGREEMENT, including coverage for any owned, hired, non-owned or rented vehicles, in an amount not less than \$1,000,000 combined single limit for each accident.

Professional liability (errors & omissions) insurance. CONSULTANT shall maintain professional liability insurance that covers the Services to be performed in connection with this AGREEMENT, in the minimum amount of \$1,000,000 per claim and in the aggregate. Any policy inception date, continuity date, or retroactive date must be before the effective date of this AGREEMENT and CONSULTANT agrees to maintain continuous coverage through a period no less than three (3) years after completion of the services required by this AGREEMENT.

Workers' compensation insurance. CONSULTANT shall maintain Workers' Compensation Insurance (Statutory Limits) and Employer's Liability Insurance (with limits of at least \$1,000,000).

CONSULTANT shall submit to CITY, along with the certificate of insurance, a Waiver of Subrogation endorsement in favor of CITY, its officers, agents, employees and volunteers.

Umbrella or excess liability insurance. [Optional depending on limits required]. CONSULTANT shall obtain and maintain an umbrella or excess liability insurance policy with limits that will provide bodily injury, personal injury and property damage liability coverage at least as broad as the primary coverages set forth above, including commercial general liability, automobile liability, and employer's liability. Such policy or policies shall include the following terms and conditions:

- A drop down feature requiring the policy to respond if any primary insurance that would otherwise have applied proves to be uncollectible in whole or in part for any reason;
- Pay on behalf of wording as opposed to reimbursement;
- Concurrency of effective dates with primary policies;
- Policies shall "follow form" to the underlying primary policies; and
- Insureds under primary policies shall also be insureds under the umbrella or excess policies.

Other provisions or requirements

Proof of insurance. CONSULTANT shall provide certificates of insurance to CITY as evidence of the insurance coverage required herein, along with a waiver of subrogation endorsement for workers' compensation. Insurance certificates and endorsements must be approved by City's Risk Manager prior to commencement of performance. Current certification of insurance shall be kept on file with CITY at all times during the term of this contract. CITY reserves the right to require complete, certified copies of all required insurance policies, at any time.

Duration of coverage. CONSULTANT shall procure and maintain for the duration of the contract insurance against claims for injuries to persons or damages to property, which may arise from or in connection with the performance of the Work hereunder by CONSULTANT, his agents, representatives, employees or subconsultants.

Primary/noncontributing. Coverage provided by CONSULTANT shall be primary and any insurance or self-insurance procured or maintained by CITY shall not be required to contribute with it. The limits of insurance required herein may be satisfied by a combination of primary and umbrella or excess insurance. Any umbrella or excess insurance shall contain or be endorsed to contain a provision that such coverage shall also apply on a primary and non-contributory basis for the benefit of CITY before the CITY's own insurance or self-insurance shall be called upon to protect it as a named insured.

City's rights of enforcement. In the event any policy of insurance required under this AGREEMENT does not comply with these specifications or is canceled and not replaced, CITY has the right but not the duty to obtain the insurance it deems necessary and any premium paid by CITY will be promptly reimbursed by CONSULTANT or CITY will withhold amounts sufficient to pay premium from CONSULTANT payments. In the alternative, CITY may cancel this AGREEMENT.

Acceptable insurers. All insurance policies shall be issued by an insurance company currently authorized by the Insurance Commissioner to transact business of insurance or is on the List of Approved Surplus Line Insurers in the State of California, with an assigned policyholders' Rating of A- (or higher) and Financial Size Category Class VI (or larger) in accordance with the latest edition of Best's Key Rating Guide, unless otherwise approved by the City Manager.

Waiver of subrogation. All insurance coverage maintained or procured pursuant to this Agreement shall be endorsed to waive subrogation against CITY, its elected or appointed officers, agents, officials, employees and volunteers or shall specifically allow CONSULTANT or others providing insurance evidence in compliance with these specifications to waive their right of recovery prior to a loss. CONSULTANT hereby waives its own right of recovery against CITY, and shall require similar written express waivers and insurance clauses from each of its subconsultants.

Enforcement of contract provisions (non estoppel). CONSULTANT acknowledges and agrees that any actual or alleged failure on the part of the CITY to inform CONSULTANT of non-compliance with any requirement imposes no additional obligations on the CITY nor does it waive any rights hereunder.

Requirements not limiting. Requirements of specific coverage features or limits contained in this Section are not intended as a limitation on coverage, limits or other requirements, or a waiver of any coverage normally provided by any insurance. Specific reference to a given coverage feature is for purposes of clarification only

as it pertains to a given issue and is not intended by any party or insured to be all inclusive, or to the exclusion of other coverage, or a waiver of any type. If the Consultant maintains higher limits than the minimums shown above, the CITY requires and shall be entitled to coverage for the higher limits maintained by the Consultant. Any available insurance proceeds in excess of the specified minimum limits of insurance and coverage shall be available to the CITY.

Notice of cancellation. Consultant agrees to oblige its insurance agent or broker and insurers to provide to CITY with a thirty (30) day notice of cancellation (except for nonpayment for which a ten (10) day notice is required) or nonrenewal of coverage for each required coverage.

Additional insured status. General liability policies shall provide or be endorsed to provide that CITY and its officers, officials, employees, and agents, and volunteers shall be additional insureds under such policies. This provision shall also apply to any excess/umbrella liability policies.

Prohibition of undisclosed coverage limitations. None of the coverages required herein will be in compliance with these requirements if they include any limiting endorsement of any kind that has not been first submitted to CITY and approved of in writing.

Separation of insureds. A severability of interests provision must apply for all additional insureds ensuring that Consultant's insurance shall apply separately to each insured against whom claim is made or suit is brought, except with respect to the insurer's limits of liability. The policy(ies) shall not contain any cross-liability exclusions.

Pass through clause. CONSULTANT agrees to ensure that its subconsultants, subcontractors, and any other party involved with the project who is brought onto or involved in the project by CONSULTANT, provide the same minimum insurance coverage and endorsements required of CONSULTANT. CONSULTANT agrees to monitor and review all such coverage and assumes all responsibility for ensuring that such coverage is provided in conformity with the requirements of this section. CONSULTANT agrees that upon request, all Agreements with consultants, subcontractors, and others engaged in the project will be submitted to CITY for review.

City's right to revise specifications. The CITY reserves the right at any time during the term of the contract to change the amounts and types of insurance required by giving the CONSULTANT ninety (90) days advance written notice of such change. If such change results in substantial additional costs to the CONSULTANT, the CITY and CONSULTANT may renegotiate CONSULTANT's compensation.

Self-insured retentions. Any self-insured retentions must be declared to and approved by CITY. CITY reserves the right to require that self-insured retentions be eliminated, lowered, or replaced by a deductible. Self-insurance will not be considered to comply with these specifications unless approved by CITY.

Timely notice of claims. CONSULTANT shall give CITY prompt and timely notice of claims made or suits instituted that arise out of or result from CONSULTANT's performance under this AGREEMENT, and that involve or may involve coverage under any of the required liability policies.

Additional insurance. CONSULTANT shall also procure and maintain, at its own cost and expense, any additional kinds of insurance, which in its own judgment may be necessary for its proper protection and

prosecution of the work.

**ATTACHMENT C
ADDENDA ACKNOWLEDGEMENT**

CITY OF SAND CITY

Multiuse Trail Project Final Design Request for Proposals

ACKNOWLEDGEMENT OF ADDENDA

The undersigned acknowledges the Bidder's receipt of the following addenda to this RFP and has incorporated information or changes in said addenda within its submittal (if no addenda were received, write "None" in the first blank):

Addendum No: _____	Dated: _____
Addendum No: _____	Dated: _____
Addendum No: _____	Dated: _____
Addendum No: _____	Dated: _____
Addendum No: _____	Dated: _____

Note: It is the Bidder's responsibility to ensure it receives all addenda which are posted on the City of Sand City website at [Requests for Proposals | Sand City, CA](#)

Authorized Official Signature

Date of Signature

Authorized Official Name

Authorized Official Title

Business Name of Bidder: _____
(Signer must match authorized official shown on Bidder Information)

ATTACHMENT D

Project Limits



Source: Monterey County GIS 2023, Google Earth 2023

- | | | | |
|--|--|-----------------------------|---|
| | | City Limit | Proposed Bike Trail Route |
| | | Potential Parking Locations | Connection to Monterey Recreational Trail |
| | | South of Tioga Development | MST SURF Line Station |



Proposed Multiuse Trail and Bike Lane Improvements

ATTACHMENT E

30% Design Plans including Aerial/ROW/Utility Survey and Photos Link

EXHIBIT B

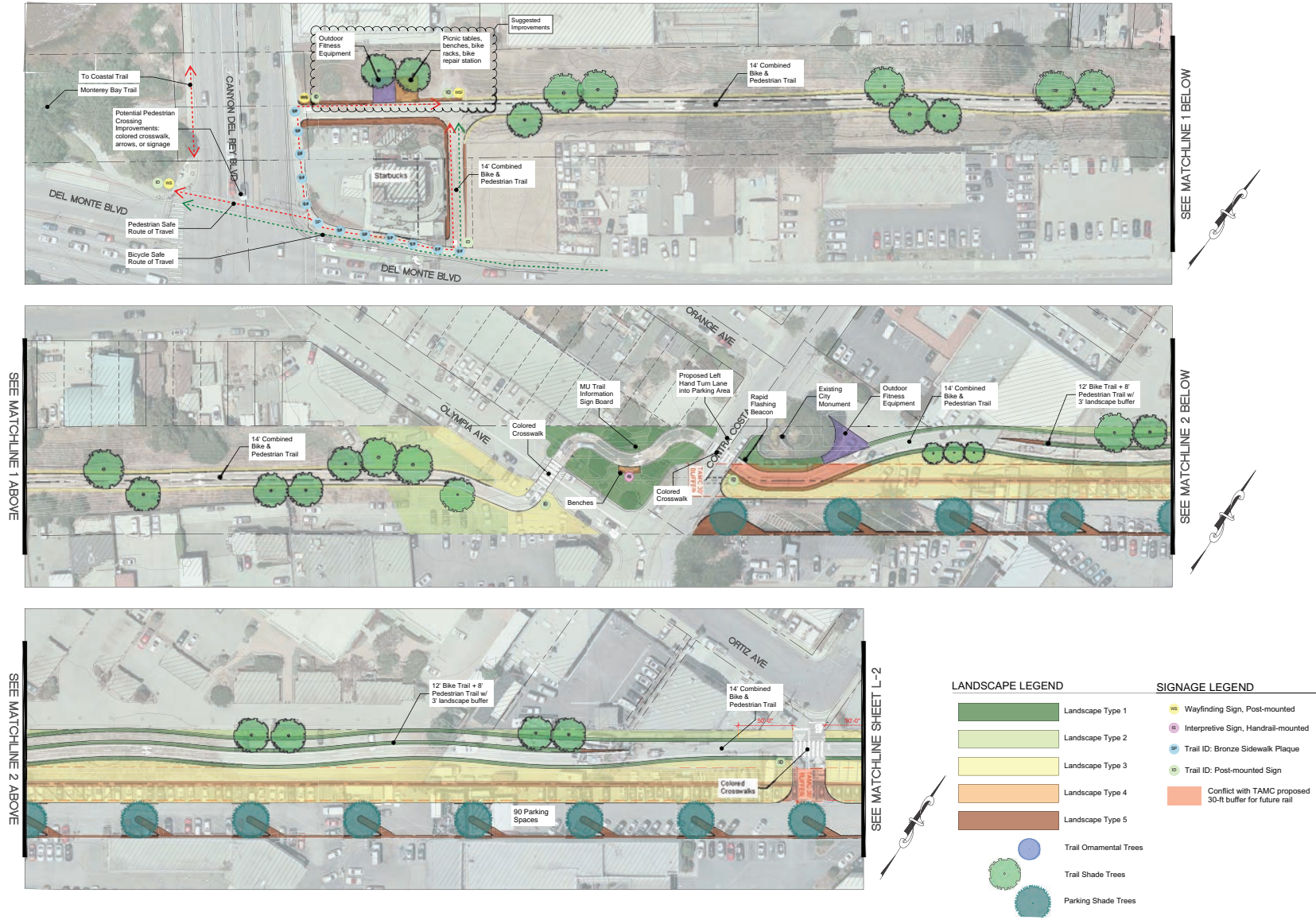

0 145 feet

Source: BFS Landscape Architects 2025

Figure 1
 Sand City Multiuse Trail Sections 1-3
 Sand City Multiuse Trail



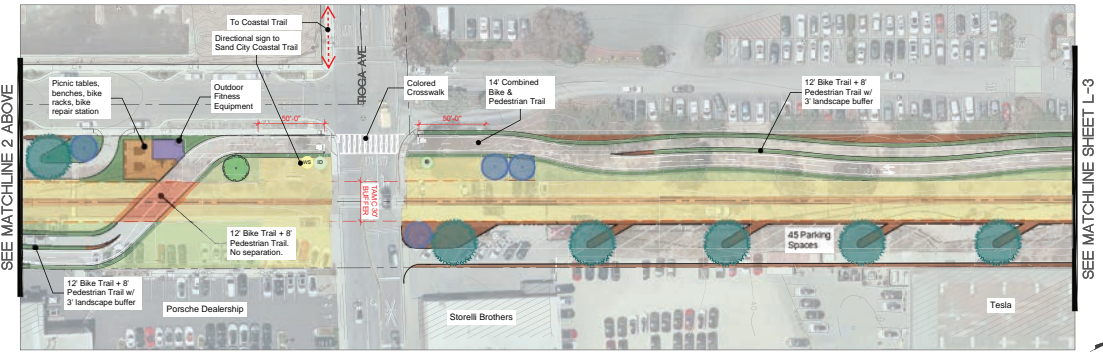
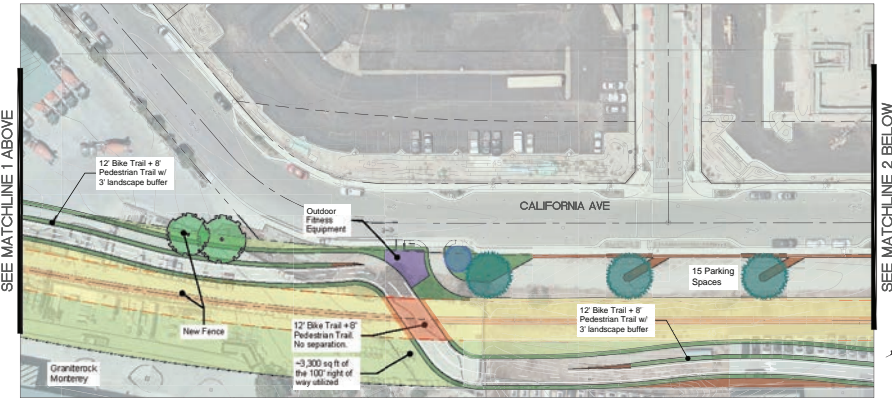

SIGNAGE LEGEND

- Wayfinding Sign, Post-mounted
- Interpretive Sign, Handrail-mounted
- Trail ID: Bronze Sidewalk Plaque
- Trail ID: Post-mounted Sign
- Conflict with TAMC proposed 30-ft buffer for future rail

LANDSCAPE LEGEND

- Landscape Type 1
- Landscape Type 2
- Landscape Type 3
- Landscape Type 4
- Landscape Type 5
- Trail Ornamental Trees
- Trail Shade Trees
- Parking Shade Tree



Source: BFS Landscape Architects 2025

Figure 2
Sand City Multiuse Trail Sections 4-6

Sand City Multiuse Trail



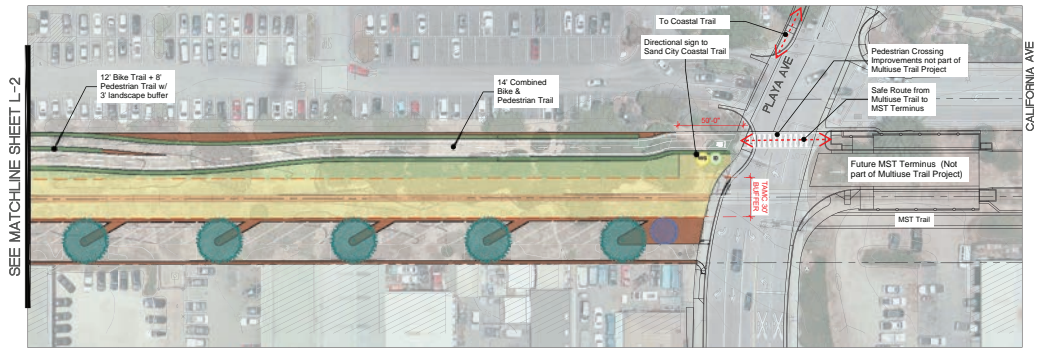

LANDSCAPE LEGEND

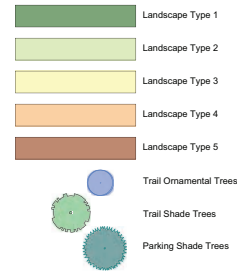

SIGNAGE LEGEND

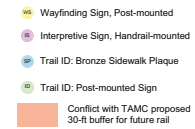

TREE LEGEND



ARBUTUS UNEDO
STRAWBERRY TREE



CEANOTHUS THYRSIFLORUS
BLUEBLOSSOM

TREE LEGEND



MELALEUCA QUINQUENERVIA
PAPERBARK TREE



TRISTANIA LAURINA 'ELEGANT'
ELEGANT WATER GUM

TREE LEGEND



LAGUNARIA PATERSONIA
PRIMROSE TREE



LOPHOSTEMON CONFERTUS
BRISBANE BOX



MELALEUCA LINARIFOLIA
FLAX-LEAF PAPERBARK

LANDSCAPE LEGEND

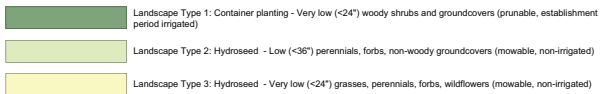

LANDSCAPE LEGEND

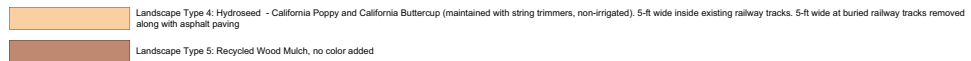

ESCHSCHOLZIA CALIFORNICA
CALIFORNIA POPPY



Source: BFS Landscape Architects 2025

Figure 3
Sand City Multiuse Trail Section 7 and Tree Legend

Sand City Multiuse Trail





MULTIUSE TRAIL PROJECT

CITY OF SAND CITY, MONTEREY COUNTY, CALIFORNIA
 PROJECT NO. 1240127001
 MAY 2025
 30% SUBMITTAL

LOCATION MAP

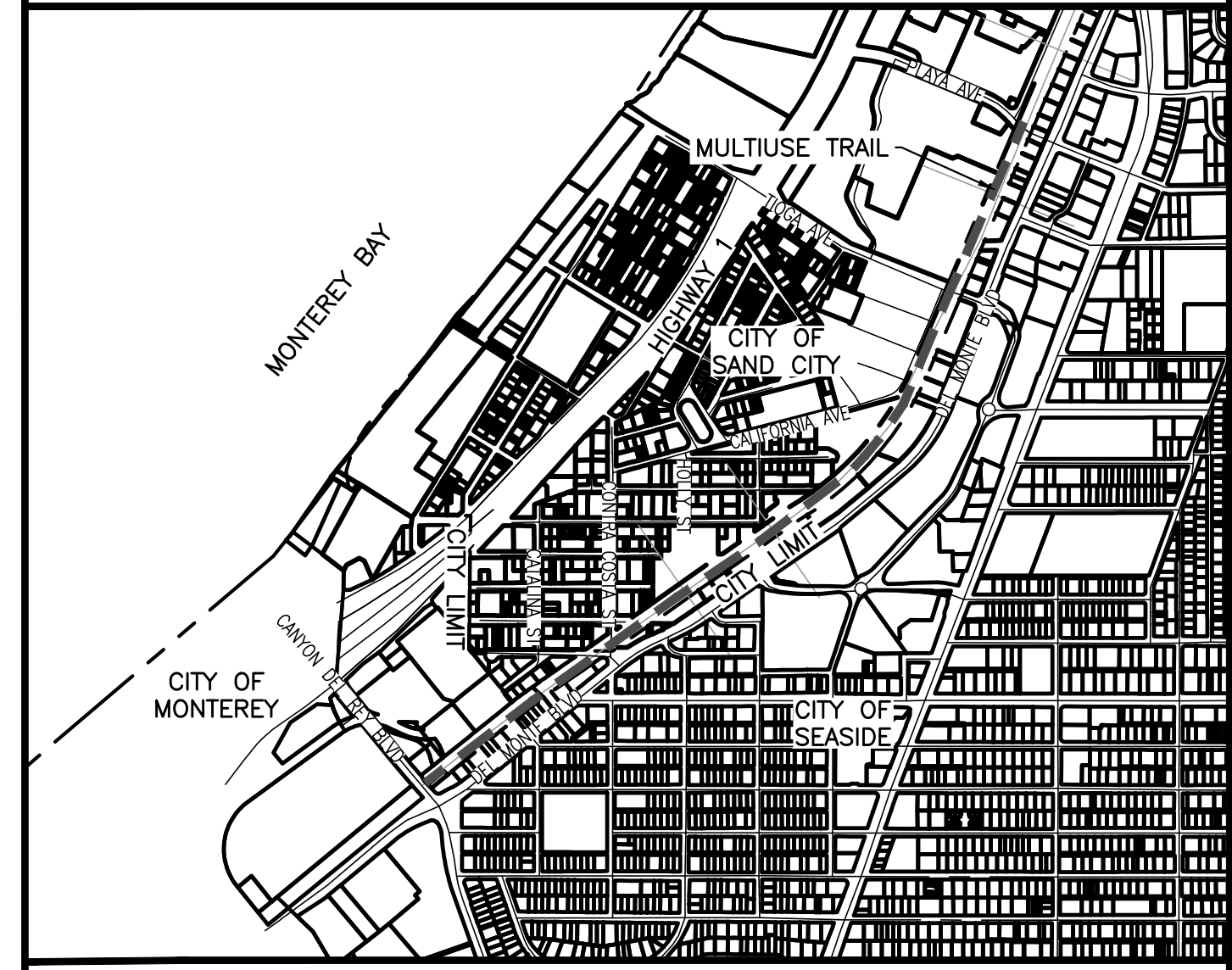

REVISIONS	NO.	DATE	INITIAL	DESCRIPTION
	1			NOT FOR CONSTRUCTION
	2			DRAFT SUBMITTAL

PROJECT TEAM

OWNER	CITY OF SAND CITY 1 PENDERGRASS WAY SAND CITY, CA 93955 VIBEKE NORGAARD, CITY MANAGER TEL. 831-394-3054
CIVIL ENGINEER	HARRIS & ASSOCIATES 60 W ALISAL ST, SUITE 200 SALINAS, CA 93901 ELIZABETH REYES, P.E. TEL. 949-536-2516
TRAFFIC AND LIGHTING	TL ENGINEERING 314 COLVILLE DR SAN JOSE, CA 95123 LEO TRUJILLO, P.E., T.E. TEL. 209-829-1553
LANDSCAPE ARCHITECT	BFS LANDSCAPE ARCHITECTS 1580 W EL CAMINO REAL, SUITE 12 MOUNTAIN VIEW, CA 94040 ADIT PAL TEL. 650-326-6622
SURVEY	POLARIS LAND SURVEYING P.O. BOX 1378 CARMEL VALLEY, CA 93924 LYNN A. KOVACH, PLS TEL. 831-659-9564

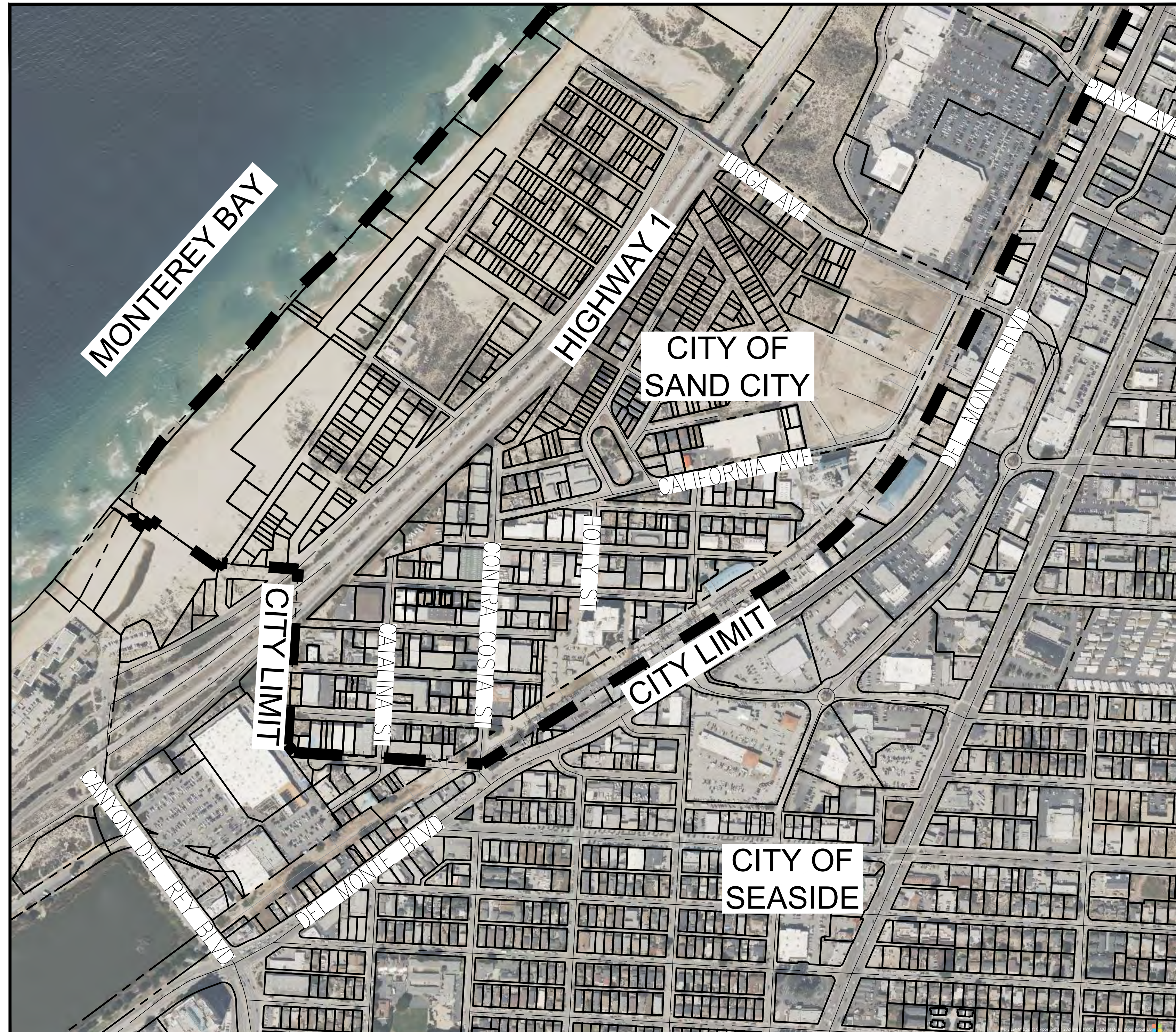

SHEET INDEX

SHEET NO.	DRAWING NO.	TITLE
1	C1.0	COVER SHEET
2	C2.1	GENERAL NOTES
3	C2.2	INDEX MAP
4-6	C3.1-C3.3	DEMOLITION PLANS
7-21	C4.1-C4.15	MULTIUSE TRAIL PLAN & PROFILE
22-26	C4.16-C4.20	PARKING LOT IMPROVEMENTS
27-29	C5.1-C5.3	SIGNING AND STRIPING
XX-XX	LX-LX	LIGHTING
XX-XX	LS1.1-LS1.9	LANDSCAPE IMPROVEMENTS

ABBREVIATIONS

AB	AGGREGATE BASE	MAX	MAXIMUM
AC	ASPHALT CONCRETE	MID	MIDDLE
BC	BEGINNING OF CURVE	MIN	MINIMUM
BEG	BEGIN	MRSWMP	MONTEREY REGIONAL STORMWATER MANAGEMENT PROGRAM
BFP	BACK FLOW PREVENTER	NG	NATURAL GROUND
BLDG	BUILDING	NPDES	NATIONAL POLLUTANT DISCHARGE ELIMINATION SYSTEM
BMP	BEST MANAGEMENT PRACTICE	OB	OVERBUILD
BO	BLOW OFF VALVE	OH	OVERHEAD ELECTRIC
BOW	BACK OF WALK	PCC	PORTLAND CEMENT CONCRETE
CB	CATCH BASIN	PCR	POST-CONSTRUCTION REQUIREMENTS
CG&S	CURB, GUTTER, & SIDEWALK	PL	PROPERTY LINE
CL	CENTERLINE	PRC	POINT OF RETURN CURVE
CO	CLEAN OUT	PT	POINT OF TANGENCY
CONC	CONCRETE	PUE	PUBLIC UTILITY EASEMENT
COR	CORNER	PVC	POLYVINYL CHLORIDE
C.O.S.	CITY OF SEASIDE	RCP	REINFORCED CONCRETE PIPE
CR	CROWN	ROW	RIGHT OF WAY
DI	DROP INLET/DITCH INLET	SB	SOUND BARRIER
DW	DRIVEWAY	SC	SAW CUT
DWG	DRAWING	SWCP	STORMWATER CONTROL PLAN
EC	END OF CURVE	SCSD	SEASIDE COUNTY SANITATION DISTRICT
EM	EASEMENT	SDMH	STORM DRAIN MANHOLE
EP	EDGE OF PAVEMENT	SLB	SLAB
ER	END OF RETURN	S.L.D.	SEE LANDSCAPE DRAWINGS
(E)	EXISTING	SO	SIDE OPENINGS
(F)	FUTURE	SS	SANITARY SEWER
FF	FACE OF CURB	SSMH	SANITARY SEWER MANHOLE
FG	FINISH FLOOR	STA	STATION
FF	FINISH GRADE	STD	STANDARD
FL	FIRE HYDRANT	TB	TOP OF BANK
FL	FLOW LINE	TBR	TO BE REMOVED
GB	GRADE BREAK	TC	TOP OF CURB
GRT	GRATE	TI	TRAFFIC INDEX
HGL	HYDRAULIC GRADE LINE	TW	TOP OF WALL
HL	HINGE LINE	TYP	TYPICAL
ICV	IRRIGATION CONTROL VALVE	UG	UNDERGROUND GAS
INV	INVERT	UT	UNDERGROUND TELEPHONE
JP	JOINT POLE	W	WATER
JT	JOINT TRENCH	WV	WATER VALVE
L	LENGTH		
LID	LOW IMPACT DEVELOPMENT		
LL	LOT LINE		
LP	LOW POINT		
LS	LANDSCAPE		

CONTRACTOR MUST POTHOLE ALL EXISTING UTILITIES AS FIRST ORDER OF WORK PRIOR TO CONSTRUCTION OF PROPOSED IMPROVEMENTS.



GENERAL MAP
 SCALE: 1"=300'

Harris & Associates

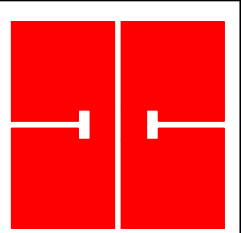

60 W Alisal Street, Suite 200, Salinas, CA 93901
 WeAreHarris.com
 p. 831.233.9242

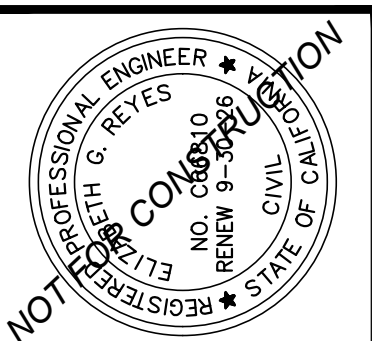

CITY OF SAND CITY
 1 PENDERGRASS WAY, SAND CITY, CA 93955
 PROJECT TITLE
 MULTIUSE TRAIL PROJECT

DESIGNED BY: IB
 DATE: 5/15/25
 SCALE: AS NOTED
 PROJECT NO.
 1240127001
 DRAWING NO.
 C1.0
 SHEET 1 OF XX

GENERAL NOTES

GENERAL

- ALL WORK AND MATERIALS SHALL COMPLY WITH THE SPECIFICATIONS, STANDARDS AND ORDINANCES OF THE CITY OF SAND CITY, CITY OF SEASIDE, AND THE STATE STANDARD SPECIFICATIONS, CITY STANDARD DRAWINGS AND DETAILS ARE AVAILABLE ONLINE.
- ALL EXISTING IMPROVEMENTS, INCLUDING BUT NOT LIMITED TO LANDSCAPING, FENCES, DRIVEWAYS, ACCESS ROADS, CURB, GUTTER, SIDEWALK, CULVERTS, DRAINS, AND MONUMENTS, SHALL BE RESTORED TO THE CONDITION IN WHICH THEY WERE, OR BETTER, BEFORE EXCAVATION WAS MADE. SEPARATE PAYMENT FOR RESTORATION OF EXISTING IMPROVEMENTS TO THEIR ORIGINAL CONDITION WILL NOT BE MADE. COMPENSATION FOR THIS TASK SHALL BE CONSIDERED AS INCLUDED IN THE VARIOUS BID ITEMS OF WORK INVOLVED. SOME EXISTING IMPROVEMENTS MAY NOT BE INCLUDED ON PLANS. CONTRACTOR SHALL INSPECT THE SITE IN ORDER TO SATISFY HIMSELF/HERSELF OF THE ACTUAL EXISTING SITE CONDITIONS.
- VEGETATION AND IMPROVEMENTS SHALL BE REMOVED ONLY WHEN DIRECTED IN WRITING BY THE ENGINEER. NO TREES, VEGETATION OR IMPROVEMENTS (INCLUDING FENCES) SHALL BE REMOVED WITHOUT THE PRIOR WRITTEN CONSENT AND APPROVAL OF THE ENGINEER OR UNLESS OTHERWISE SPECIFIED IN THIS PLAN SET.
- ALL EXISTING UTILITIES AND IMPROVEMENTS THAT BECOME DAMAGED DURING CONSTRUCTION SHALL BE COMPLETELY RESTORED BY THE CONTRACTOR AT CONTRACTOR'S EXPENSE TO THE SATISFACTION OF THE CITY.
- CONTRACTOR SHALL BE RESPONSIBLE FOR DESIGN, INSTALLATION, AND REMOVAL OF ALL REQUIRED SHORING, SHEETING, AND BRACING, PER STATE AND FEDERAL REQUIREMENTS.
- CONTRACTOR SHALL AT ALL TIMES HAVE AT THE JOB SITE SUFFICIENT PUMPING EQUIPMENT READY FOR IMMEDIATE USE. THE TRENCHES AND EXCAVATIONS SHALL BE KEPT ENTIRELY FREE OF WATER. WATER SHALL BE DISPOSED OF IN SUCH A MANNER AS WILL NOT CAUSE INJURY TO PUBLIC OR PRIVATE PROPERTY, NOR BE A MENACE TO PUBLIC HEALTH.
- NO OPEN TRENCHES SHALL BE ALLOWED AT THE END OF ANY CONSTRUCTION WORK DAY. ALL EXCAVATIONS SHALL BE FILLED IN WITH TEMPORARY PAVING AT THE END OF EACH WORK DAY.
- CONTRACTOR SHALL CONFINE HIS OPERATIONS AND ACTIVITIES WITHIN THE PROJECT LIMITS CONSISTING OF EASEMENTS, ROAD RIGHT-OF-WAY, AND RIGHTS OF ENTRY AS SHOWN ON THE PLANS AND AS DIRECTED BY THE ENGINEER.
- THE EXACT LOCATION OF PROPOSED FACILITIES MAY BE FIELD ADJUSTED IF PROPOSED BY THE CONTRACTOR AND APPROVED BY THE ENGINEER PRIOR TO INSTALLATION.
- IF ARCHAEOLOGICAL MATERIALS ARE UNCOVERED DURING GRADING, TRENCHING, OR OTHER EXCAVATION, EARTHWORK WITHIN 100 FEET OF THIS AREA SHALL BE STOPPED UNTIL A PROFESSIONAL ARCHAEOLOGIST WHO IS CERTIFIED BY THE SOCIETY FOR CALIFORNIA ARCHAEOLOGY (SCA) OR THE SOCIETY OF PROFESSIONAL ARCHAEOLOGISTS (SOPA) HAS HAD AN OPPORTUNITY TO EVALUATE THE SIGNIFICANCE OF THE FIND AND SUGGEST APPROPRIATE MITIGATION MEASURES, IF THEY ARE DEEMED NECESSARY.
- ALL SEWER MAINS AND SERVICES SHALL BE SEPARATED FROM WATER MAINS AND SERVICES PER STATE HEALTH DEPARTMENT STANDARDS.
- CONTRACTOR IS RESPONSIBLE FOR IDENTIFYING AND ACQUIRING LAYDOWN AREA TO BE USED FOR STAGING AND MATERIAL STORAGE DURING CONSTRUCTION.
- FACILITIES DISTURBED DURING CONSTRUCTION SHALL BE RE-INSTALLED IN ACCORDANCE WITH RESPECTIVE CITY STANDARD DETAILS. THE EXACT LOCATION MAY BE FIELD ADJUSTED IF REQUESTED BY THE CONTRACTOR AND APPROVED BY THE ENGINEER PRIOR TO INSTALLATION.

PERMITS

- THE CONTRACTOR SHALL NOTIFY CITY INSPECTOR AT LEAST 48 HOURS IN ADVANCE OF ANY WORK THAT WILL REQUIRE INSPECTION BY THE RESPECTIVE UTILITY COMPANIES. THIS SHALL INCLUDE, BUT NOT BE LIMITED TO, NATURAL GAS, ELECTRICAL, TELEPHONE, AND CABLE TELEVISION, FIBER OPTICS CABLES, ETC.
- IT IS THE RESPONSIBILITY OF THE CONTRACTOR TO OBTAIN ALL NECESSARY PERMITS AND LICENSES TO PERFORM THE IMPROVEMENTS IN THESE PLANS FROM THE APPROPRIATE AGENCIES AND TO COMPLY WITH THE AGENCIES' REQUIREMENTS. THE CONTRACTOR MUST COMPLY WITH ALL APPLICABLE NATIONAL, STATE, AND LOCAL LAWS.
- ANY WORK WITHIN PROPERTY BELONGING TO THE STATE OF CALIFORNIA DEPARTMENT OF PARKS AND RECREATION SHALL BE IN ACCORDANCE WITH THE EXECUTED RIGHT OF ENTRY (ROE) PERMIT BETWEEN THE STATE OF CALIFORNIA DEPARTMENT OF PARKS AND RECREATION AND THE CITY OF SAND CITY. CONTRACTOR SHALL OBTAIN A COPY OF THE EXECUTED ROE PERMIT ON SITE AT ALL TIMES DURING THE COURSE OF CONSTRUCTION.

SAFETY

- SAFETY MEASURES: AT ALL TIMES, INCLUDING NON-WORKING HOURS, THE CONTRACTOR SHALL BE SOLELY AND COMPLETELY RESPONSIBLE FOR CONDITIONS OF THE JOB SITE, CONTRACTOR'S OPERATION, AND/OR MATERIALS AND EQUIPMENT STORED IN THE STAGING AREAS, INCLUDING SAFETY OF PERSONS AND PROPERTY, AND FOR ALL NECESSARY INDEPENDENT ENGINEERING REVIEWS OF THE CONDITIONS. THE ENGINEER'S JOB SITE REVIEW IS NOT INTENDED TO INCLUDE REVIEW OF THE ADEQUACY OF THE CONTRACTOR'S SAFETY MEASURES.
- WARNING! THE EXISTING SANITARY SEWERS ARE KNOWN TO HAVE HIGH CONCENTRATIONS OF TOXIC AND/OR EXPLOSIVE GASES. OTHER PIPELINES MAY ALSO HAVE TOXIC AND/OR EXPLOSIVE GASES. SEWER WASTEWATER MAY CONTAIN INFECTIOUS AND/OR CONTAGIOUS DISEASES AND THE CONTRACTOR SHALL OBSERVE ALL NECESSARY PRECAUTIONS.
- MANHOLE ENTRY AND/OR ENTRY TO ANY EXCAVATION GREATER THAN FOUR (4) FEET DEEP SHALL BE IN FULL COMPLIANCE WITH THE CONFINED SPACE ENTRY REQUIREMENTS OF CALIFORNIA AND FEDERAL OSHA.

TRAFFIC CONTROL

- THE CONTRACTOR SHALL PROVIDE ADEQUATE TRAFFIC CONTROLS INCLUDING FLAG PERSONS AND CHANGEABLE MESSAGE SIGNS. THE CONTRACTOR SHALL PREPARE AND SUBMIT TO THE CITY A PROJECT SPECIFIC TRAFFIC CONTROL PLAN PER SPECIFICATIONS FOR REVIEW AND APPROVAL PRIOR TO THE START OF WORK. THE TRAFFIC CONTROL PLAN SHALL BE PREPARED BY A REGISTERED CIVIL ENGINEER OR A LICENSED TRAFFIC ENGINEER IN THE STATE OF CALIFORNIA. THE CITY RESERVES THE RIGHT TO REQUIRE MODIFICATIONS TO THE APPROVED PLAN IN THE FIELD. WORK SHALL NOT BEGIN UNTIL ADEQUATE TEMPORARY BARRICADES, BARRIERS, FENCES, WARNING SIGNS, LIGHTS, OR OTHER SUCH TRAFFIC AND PEDESTRIAN WARNING AND CONTROL DEVICES ARE INSTALLED AS REQUIRED BY THE TRAFFIC CONTROL PLAN.
- ACCESS TO EACH PROPERTY SHALL BE PROVIDED AT ALL TIMES. IF DURING THE COURSE OF CONSTRUCTION IT BECOMES NECESSARY TO RESTRICT ACCESS TO A GIVEN PROPERTY IN ORDER TO COMPLETE PROJECT IMPROVEMENTS, CONTRACTOR SHALL COORDINATE WITH PROPERTY OWNER AFTER OBTAINING APPROVAL FROM THE CITY.
- CONTRACTOR SHALL MAINTAIN CONTINUOUS PEDESTRIAN ACCESS TO ALL ADJACENT PROPERTIES THROUGHOUT DURATION OF CONSTRUCTION. CONTRACTOR SHALL PROVIDE TEMPORARY WALKWAY FACILITIES AND GUIDANCE SIGNAGE TO DIRECT THE PUBLIC THROUGH OR AROUND ACTIVE CONSTRUCTION.
- CONTRACTOR SHALL TAKE SPECIAL MEASURES TO CLEAN UP THE CONSTRUCTION SITE AND PROVIDE SMOOTH TRANSITION TO ALL ACTIVE CONSTRUCTION AREAS.
- NO MATERIALS OR EQUIPMENT SHALL BE STORED WITHIN THE PUBLIC RIGHT-OF-WAY.

STREET SURFACE NOTES

- REPLACEMENT ASPHALT CONCRETE THICKNESS SHALL MATCH EXISTING.
- THE CONTRACTOR SHALL NOT ORDER NOR PLACE ANY PORTLAND CEMENT CONCRETE OR ASPHALT CONCRETE PAVING UNTIL THE FORMS AND SUBGRADE AND/OR AGGREGATE BASE HAVE BEEN INSPECTED BY THE CITY AND APPROVED BY THE CITY.
- EDGE OF EXISTING ASPHALT PAVEMENT SHALL BE TACK COATED PRIOR TO CONSTRUCTION OF NEW ADJACENT ASPHALT PAVEMENT.
- THE FINAL OR SURFACE LAYER OF ASPHALT CONCRETE SHALL NOT BE PLACED UNTIL ALL ON-SITE IMPROVEMENTS HAVE BEEN COMPLETED AND UNTIL ALL UNACCEPTABLE CONCRETE WORK HAS BEEN REMOVED AND REPLACED, UNLESS OTHERWISE APPROVED BY THE CITY.

POLLUTION PREVENTION

- THE CONTRACTOR SHALL COMPLY WITH THE CITY'S NON-POINT SOURCE POLLUTION PREVENTION ORDINANCE AND THE STORM WATER POLLUTION PREVENTION PLAN BEST MANAGEMENT PRACTICES (BMP) FOR THIS PROJECT.

UTILITIES

- THE HORIZONTAL AND VERTICAL LOCATIONS AND TYPES OF EXISTING UTILITIES SHOWN ON THE IMPROVEMENT PLANS ARE BASED ON SURVEY AND INFORMATION FURNISHED BY SERVICING AGENCIES AND ARE TO BE SUPPLEMENTED BY ACTUAL FIELD INVESTIGATIONS AND VERIFICATIONS BY CONTRACTOR. CONTRACTOR SHALL DETERMINE DEPTHS AND EXACT LOCATIONS OF EXISTING SERVICES WHETHER SHOWN ON THE PLANS OR NOT. CONTRACTOR SHALL AVOID DAMAGES TO EXISTING UTILITIES ENCOUNTERED. ANY DAMAGE TO EXISTING FACILITIES CAUSED BY THE CONTRACT SHALL BE PREPARED AT THE CONTRACTOR'S EXPENSE. ANY ADDITIONAL COSTS IF INCURRED, AS A RESULT OF CONTRACTOR'S FAILURE TO VERIFY LOCATIONS OF EXISTING UTILITIES PRIOR TO BEGINNING OF CONSTRUCTION IN THEIR VICINITY, SHALL BE BORNE BY THE CONTRACTOR. CONTRACTOR SHALL NOTIFY THE UTILITY AGENCIES AND UNDERGROUND SERVICE ALERT (USA) AT (900) 227-2600 AT LEAST TWO (2) WORKING DAYS PRIOR TO EXCAVATING.
- THE CONTRACTOR SHALL EXERCISE NECESSARY CAUTION WHEN WORKING NEAR ALL EXISTING UTILITIES. ALL EXISTING UTILITIES, IMPROVEMENTS, STREETS, STREET MARKINGS & REFLECTORS, AND SIDEWALKS THAT BECOME DAMAGED DURING CONSTRUCTION OR ANY ACTIVITY BY CONTRACTOR OR CONTRACTOR'S REPRESENTATIVE IN ASSOCIATION WITH THIS WORK SHALL BE COMPLETELY RESTORED IN ACCORDANCE WITH STANDARDS AND REQUIREMENTS OF THE FACILITIES' OWNER, TO THE SATISFACTION OF THE CITY, AT THE CONTRACTOR'S EXPENSE AT NO ADDITIONAL COST TO BOTH THE OWNER AND THE CITY.
- EXISTING SERVICES TO THE PROPERTIES MUST BE MAINTAINED BY CONTRACTOR AT ALL TIMES DURING CONSTRUCTION. CONTRACTOR SHALL NOTIFY THE PROPERTY OWNERS OF ANY INTERRUPTION OF SERVICES PRIOR TO ANY WORK ON EXISTING UTILITY LINES.
- THE CONTRACTOR SHALL PROVIDE ACCESS TO UTILITY COMPANIES FOR MAINTENANCE AND WORK ON THEIR UTILITIES DURING THE COURSE OF THE WORK.
- ALL VALVE BOXES AND MANHOLES, IF ANY, SHALL BE ADJUSTED TO GRADE, UNLESS OTHERWISE NOTED.

SURVEY MONUMENTS

- THE CONTRACTOR IS RESPONSIBLE FOR THE PRESERVATION AND OR PERPETUATION OF ALL EXISTING MONUMENTS AND STAKES WITHIN THE CONTRACTOR'S AREA OF WORK. THE CONTRACTOR SHALL NOT DISTURB OR REMOVE ANY MONUMENTS OR STAKES WITHOUT THE WRITTEN PERMISSION OF THE CITY ENGINEER, AND SHALL BEAR THE EXPENSE OF RESETTling ANY MONUMENTS OR STAKES WHICH MAY BE DISTURBED OR REMOVED WITH OR WITHOUT PERMISSION. THE CONTRACTOR SHALL PROVIDE A MINIMUM OF 15 WORKING DAYS NOTICE TO THE CITY ENGINEER PRIOR TO DISTURBANCE OR REMOVAL OF EXISTING MONUMENTS OR STAKES. THE CONTRACTOR SHALL UTILIZE THE SERVICES OF A CALIFORNIA LICENSED LAND SURVEYOR TO RESET ALL DISTURBED OR REMOVED MONUMENTS AND STAKES OR PROVIDE WITNESS MONUMENTS, PREPARE ALL REQUIRED DOCUMENTATION AND RECORDS, AND FILE THE REQUIRED DOCUMENTATION AND RECORDS WITH THE MONTEREY COUNTY SURVEYOR.



REVISIONS	NO.	DATE	INITIAL	DESCRIPTION
	△	△	△	△
Harris & Associates				NOT FOR CONSTRUCTION
60 W Alisal Street, Suite 200, Salinas, CA 93901				DRAFT SUBMITTAL
p. 831.233.9242				WeAreHarris.com

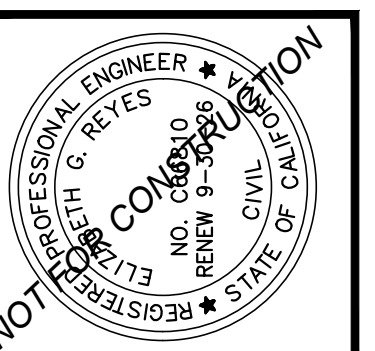

CITY OF SAND CITY	1 PENDERGRASS WAY, SAND CITY, CA 93955
PROJECT TITLE	MULTIUSE TRAIL PROJECT
SHEET DESCRIPTION	GENERAL NOTES

DESIGNED BY:	IB
DATE:	5/15/25
SCALE:	AS NOTED
PROJECT NO.	1240127001
DRAWING NO.	C2.1
SHEET	2 OF XX

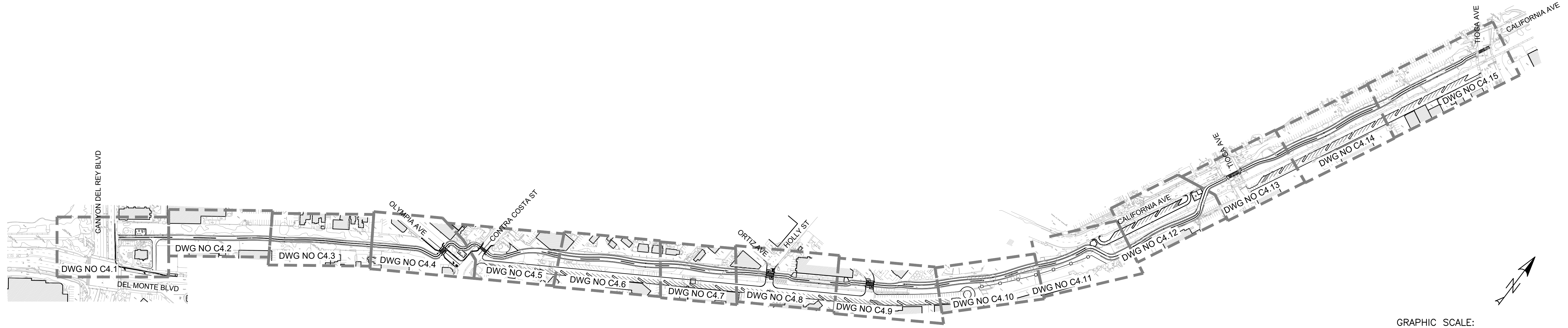

INDEX MAP

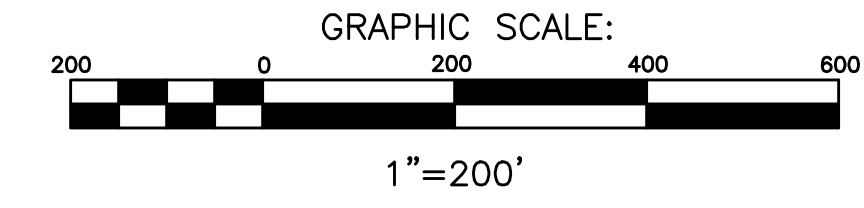

REVISIONS	NO.	DATE	INITIAL	DESCRIPTION
	△			NOT FOR CONSTRUCTION
	△			DRAFT SUBMITTAL

Harris & Associates
 60 W Alisal Street, Suite 200, Salinas, CA 93901
 p. 831.233.9242 * WeAreHarris.com

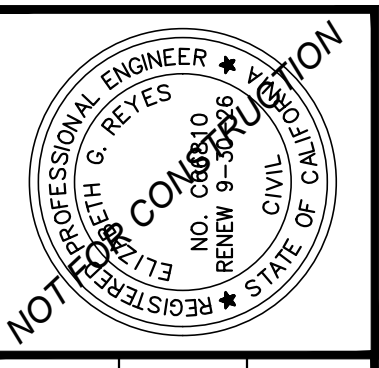

CITY OF SAND CITY
 1 PENDERGRASS WAY, SAND CITY, CA 93955
 PROJECT TITLE
 MULTIUSE TRAIL PROJECT
 SHEET DESCRIPTION
INDEX MAP

DESIGNED BY: IB
 DATE: 5/15/25
 SCALE: AS NOTED
 PROJECT NO.
 1240127001
 DRAWING NO.
C2.2
 SHEET 3 OF XX



REVISIONS	NO.	DATE	INITIAL	DESCRIPTION
	1			NOT FOR CONSTRUCTION
	2			DRAFT SUBMITTAL

Harris & Associates
 60 W Alisal Street, Suite 200, Salinas, CA 93901
 p. 831.233.9242 * WeAreHarris.com

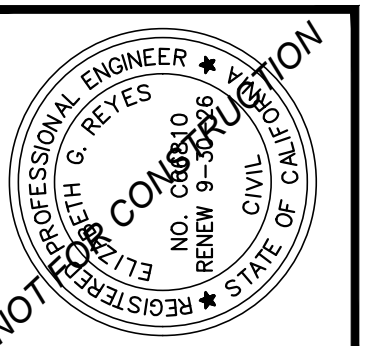

CITY OF SAND CITY
 1 PENDERGRASS WAY, SAND CITY, CA 93955
 PROJECT TITLE
 MULTITUDE TRAIL PROJECT
 SHEET DESCRIPTION
SIGNING AND STRIPING

DESIGNED BY: IB
 DATE: 5/15/25
 SCALE: AS NOTED
 PROJECT NO.
 1240127001
 DRAWING NO.
C3.1
 SHEET 4 OF XX

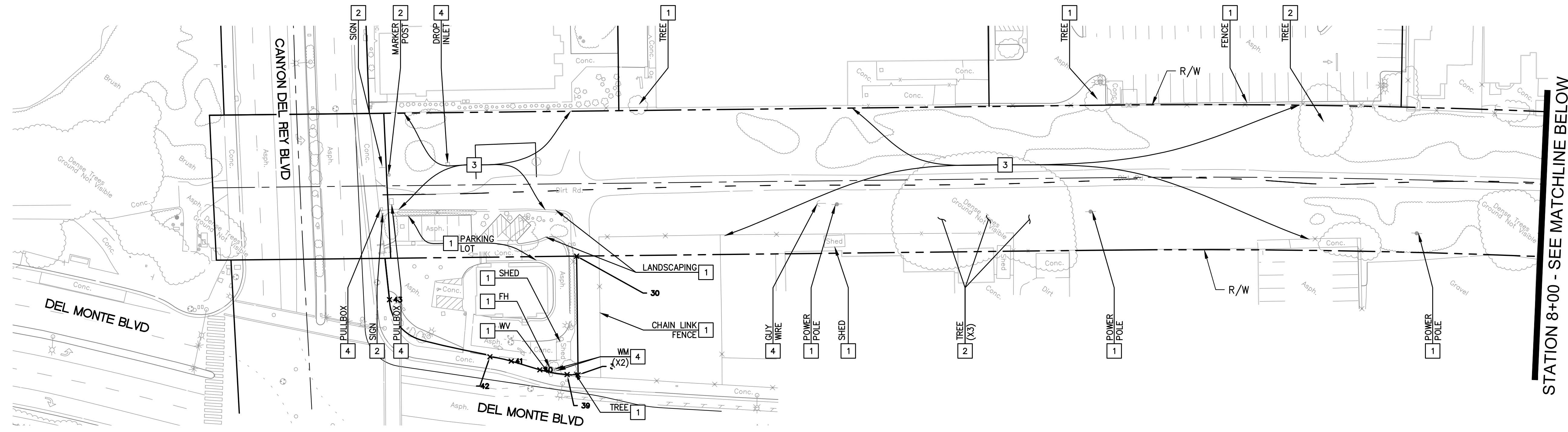

STATION 8+00 - SEE MATCHLINE BELOW

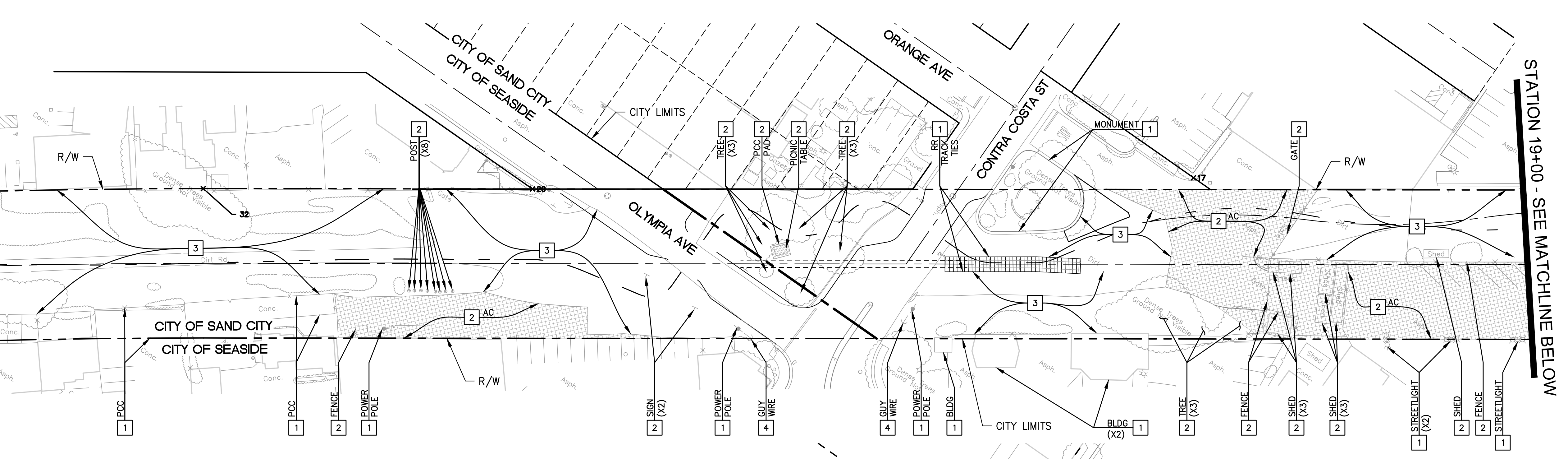

STATION 8+00 - SEE MATCHLINE ABOVE

STATION 19+00 - SEE MATCHLINE BELOW

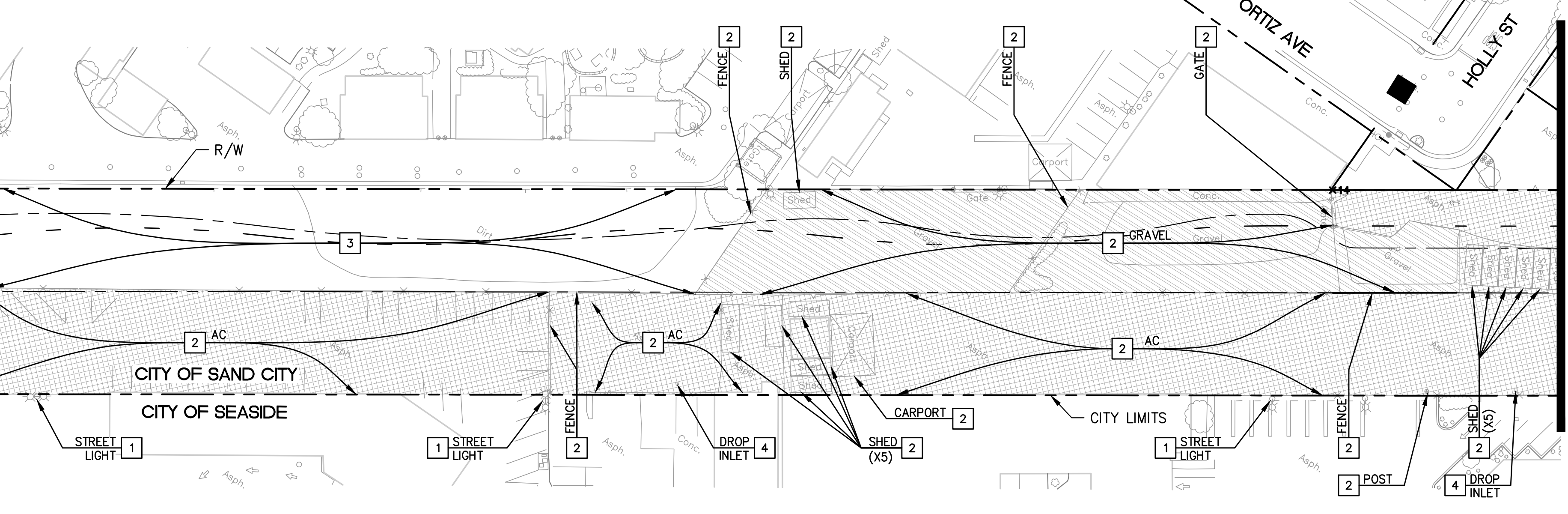

STATION 19+00 - SEE MATCHLINE ABOVE

STATION 27+00 - SEE MATCHLINE
 DWG NO - C5.2

DISPOSITION NOTES

- 1 PROTECT EXISTING IMPROVEMENT IN PLACE (TYPE PER PLAN).
- 2 REMOVE EXISTING IMPROVEMENT (TYPE PER PLAN).
- 3 CLEAR AND GRUB EXISTING GROUND PER THE SPECIFICATIONS.
- 4 ADJUST ITEM TO GRADE AS NOTED.

LEGEND

- AC REMOVAL
- PCC REMOVAL
- GRAVEL REMOVAL
- RAILROAD TRACK AND TIES

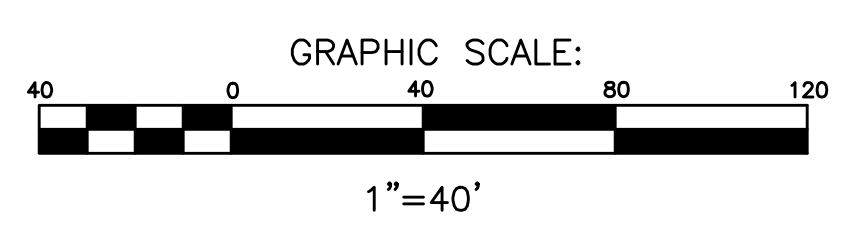



REVISIONS	NO.	DATE	INITIAL	DESCRIPTION
	1			NOT FOR CONSTRUCTION
	2			DRAFT SUBMITTAL

Harris & Associates
 60 W Alisal Street, Suite 200, Salinas, CA 93901
 p. 831.233.9242 * WeAreHarris.com

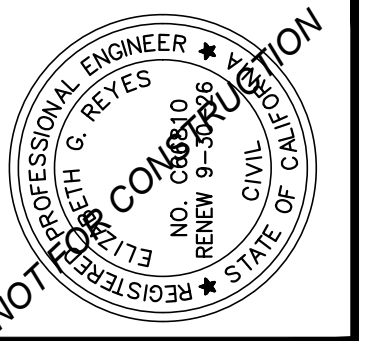

CITY OF SAND CITY
 1 PENDERGRASS WAY, SAND CITY, CA 93955
 PROJECT TITLE
 MULTIUSE TRAIL PROJECT
 SHEET DESCRIPTION
SIGNING & STRIPING

DESIGNED BY: IB
 DATE: 5/15/25
 SCALE: AS NOTED
 PROJECT NO.
 1240127001
 DRAWING NO.
 C3.2
 SHEET 5 OF XX

- DISPOSITION NOTES**
- 1 PROTECT EXISTING IMPROVEMENT IN PLACE (TYPE PER PLAN).
 - 2 REMOVE EXISTING IMPROVEMENT (TYPE PER PLAN).
 - 3 CLEAR AND GRUB EXISTING GROUND PER THE SPECIFICATIONS.
 - 4 ADJUST ITEM TO GRADE AS NOTED.

- LEGEND**
- AC REMOVAL
 - PCC REMOVAL
 - GRAVEL REMOVAL
 - RAILROAD TRACK AND TIES

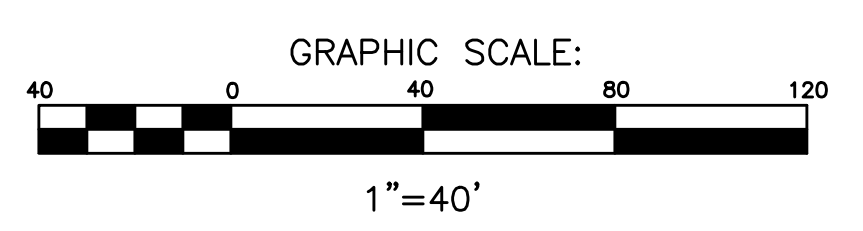
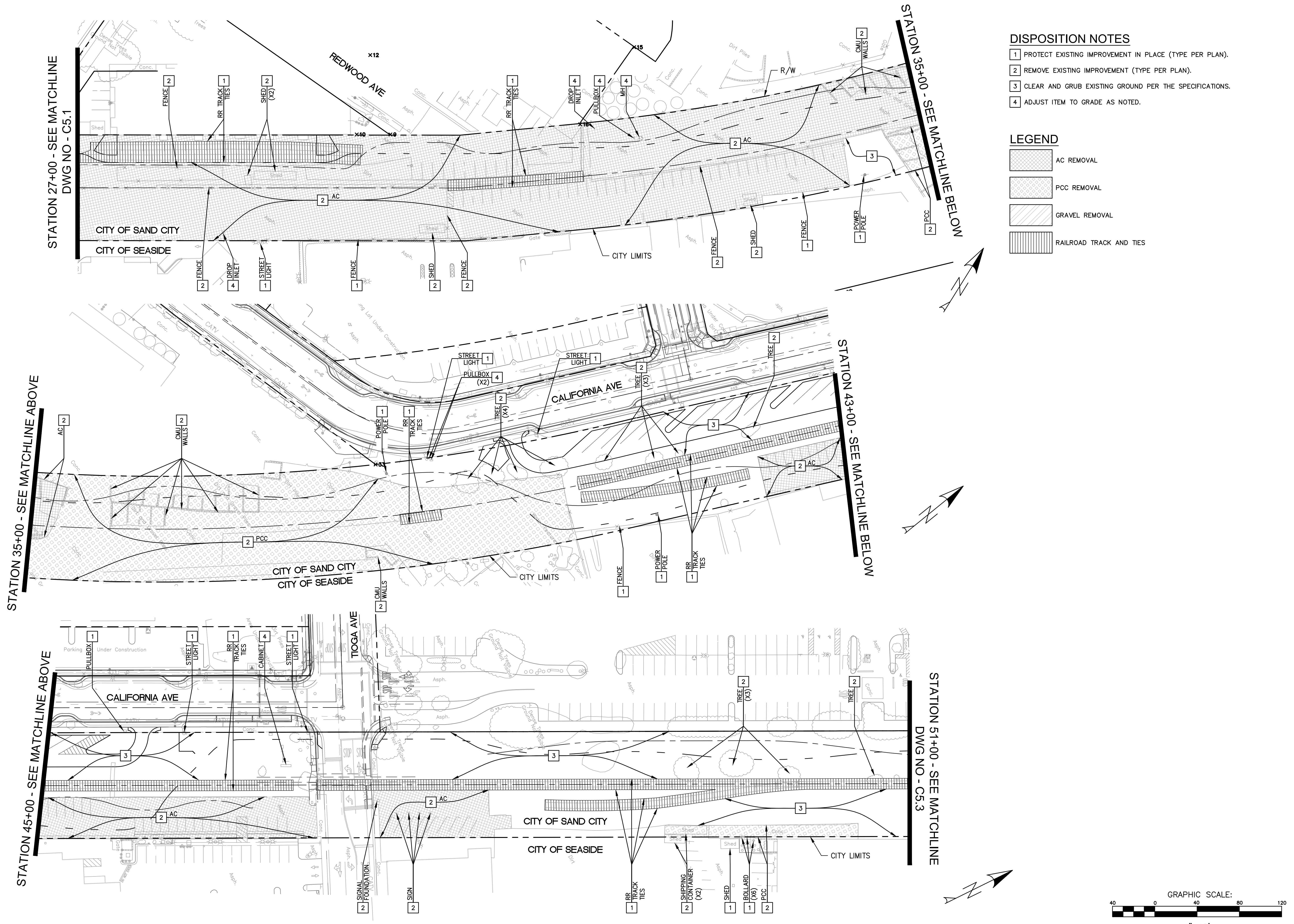

STATION 51+00 - SEE MATCHLINE
DWG NO - C5.2

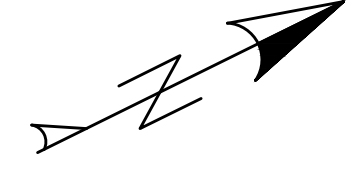
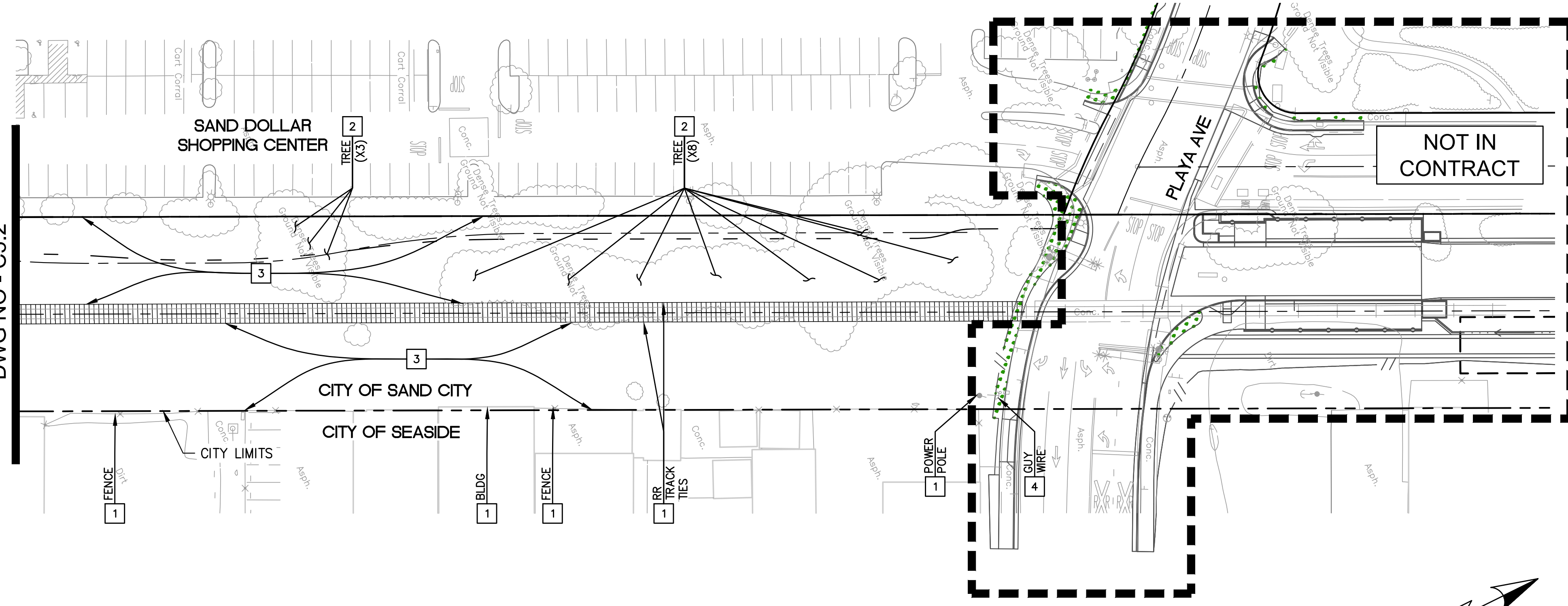

DISPOSITION NOTES

- 1 PROTECT EXISTING IMPROVEMENT IN PLACE (TYPE PER PLAN).
- 2 REMOVE EXISTING IMPROVEMENT (TYPE PER PLAN).
- 3 CLEAR AND GRUB EXISTING GROUND PER THE SPECIFICATIONS.
- 4 ADJUST ITEM TO GRADE AS NOTED.

LEGEND

- AC REMOVAL
- PCC REMOVAL
- GRAVEL REMOVAL
- RAILROAD TRACK AND TIES

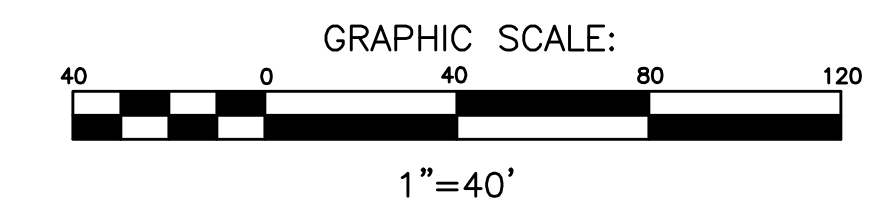

REVISIONS	NO.	DATE	INITIAL	DESCRIPTION
	1			NOT FOR CONSTRUCTION
	2			DRAFT SUBMITTAL

Harris & Associates
 60 W Alisal Street, Suite 200, Salinas, CA 93901
 p. 831.233.9242 * WeAreHarris.com

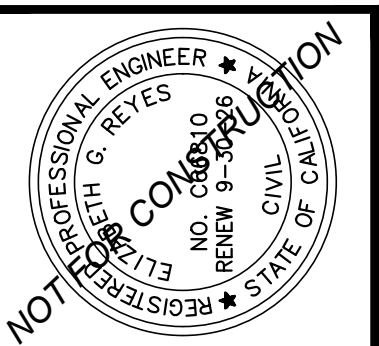

CITY OF SAND CITY
 1 PENDERGRASS WAY, SAND CITY, CA 93955
 PROJECT TITLE
 MULTIUSE TRAIL PROJECT
 SHEET DESCRIPTION
SIGNING & STRIPING

DESIGNED BY: IB
 DATE: 5/15/25
 SCALE: AS NOTED
 PROJECT NO.
 1240127001
 DRAWING NO.
C3.3
 SHEET 6 OF XX



PROFILE SCALE:
 HORIZONTAL: 1" = 20'
 VERTICAL: 1" = 4'

CONSTRUCTION NOTES

- (P) PROTECT EXISTING IMPROVEMENT IN PLACE.
- (LS) SEE PROPOSED LANDSCAPING IMPROVEMENT PLAN SHEETS XX-XX.
- (SL) SEE PROPOSED LIGHTING IMPROVEMENT PLAN SHEETS XX-XX.
- (1) CONSTRUCT 4-INCH FULL DEPTH ASPHALT CONCRETE, GRADE PG XX-XX OVER COMPACTED NATIVE TO 95% RELATIVE COMPACTION. SCARIFY AND RECOMPACT SUB BASE (6-IN MINIMUM).

REVISIONS NO.	DATE	INITIAL	DESCRIPTION
△			NOT FOR CONSTRUCTION
△			DRAFT SUBMITTAL

Harris & Associates

60 W Alisal Street, Suite 200, Salinas, CA 93901
 p. 831.233.9242 * WeAreHarris.com

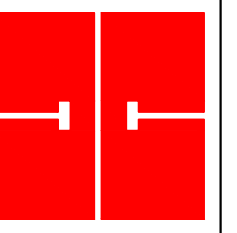

PROFILE

LEGEND

- PROPOSED ASPHALT CONCRETE PAVEMENT PER CN 1
- LANDSCAPE BUFFER (SEE LANDSCAPING PLANS SHEETS XX-XX)
- RIGHT OF WAY
- CITY LIMITS

CL CURVE AND LINE TABLE				
SEGMENT	LENGTH	BEARING	DELTA	RADIUS
C1	45.38'		1°18'00"	2000.00'
C2	169.00'		2°06'06"	4607.00'
L1	26.75'	N53°39'51"E		
L2	99.47'	N52°21'51"E		
L7	129.61'	S37°24'57"E		

PLAN

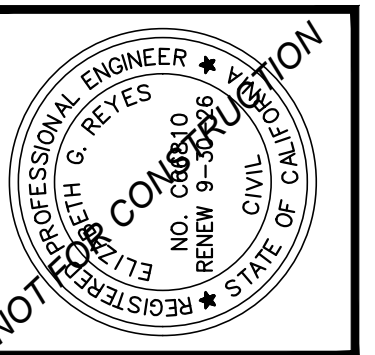
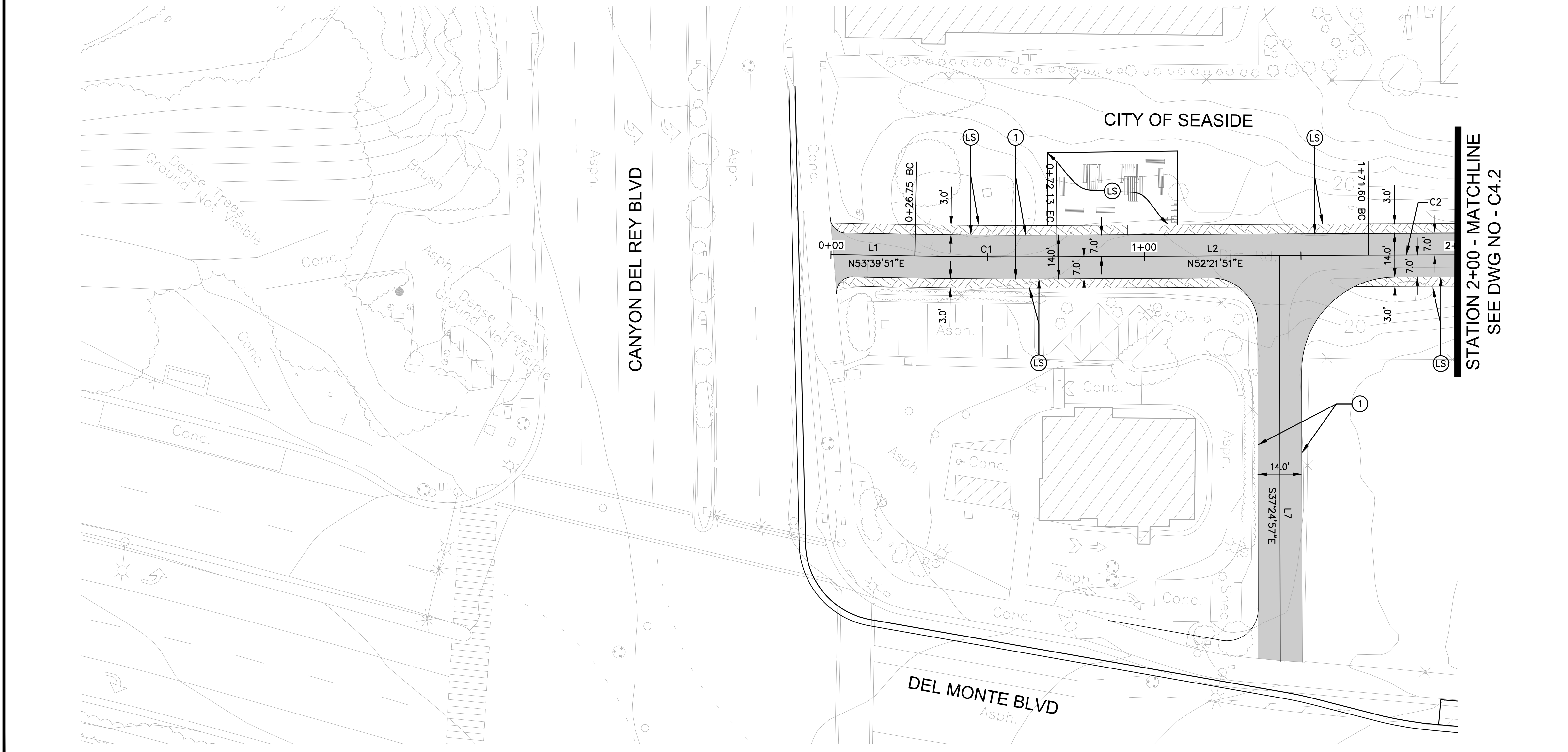
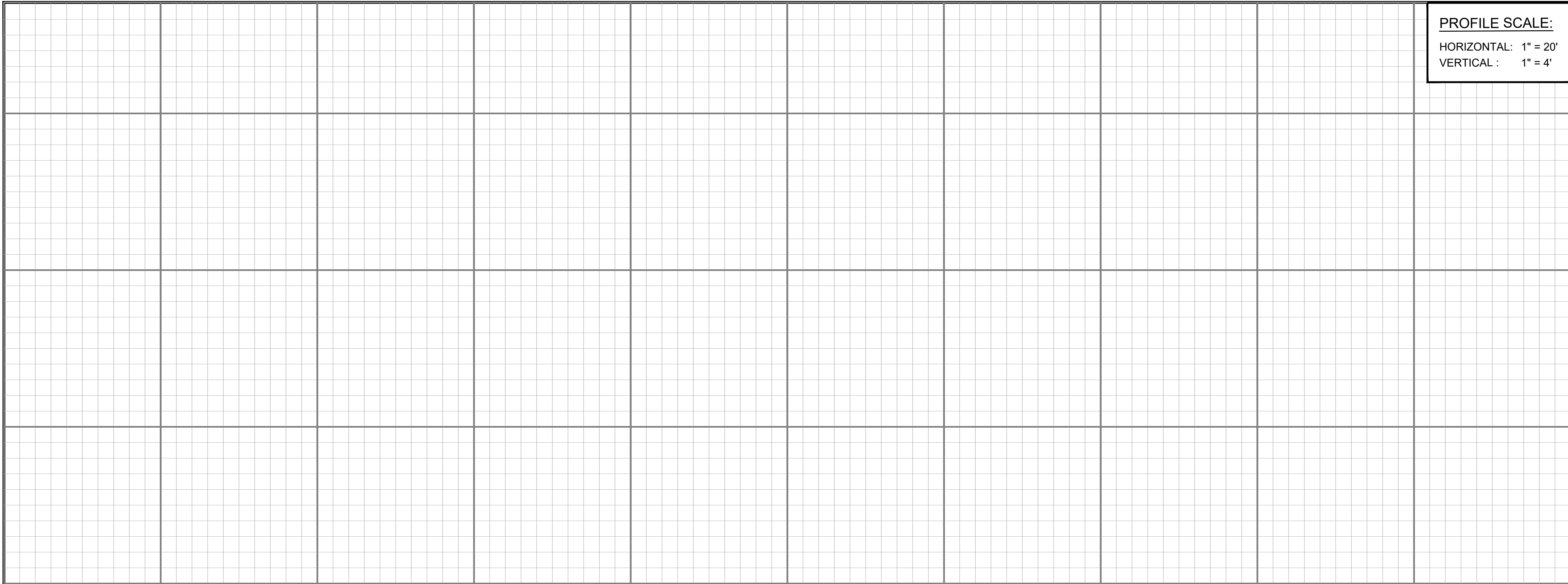
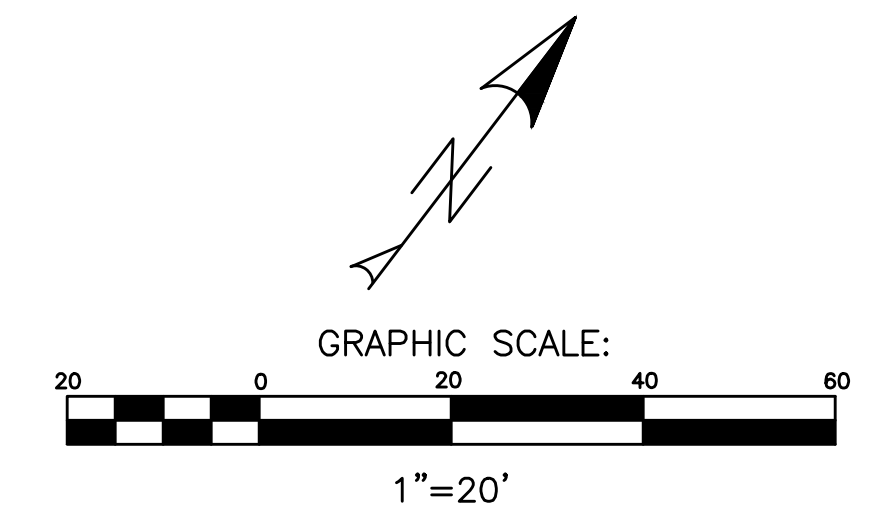

CITY OF SAND CITY
 1 PENDERGRASS WAY, SAND CITY, CA 93955
 PROJECT TITLE
 MULTIUSE TRAIL PROJECT
 SHEET DESCRIPTION
PLAN & PROFILE

DESIGNED BY: IB
 DATE: 5/15/25
 SCALE: AS NOTED
 PROJECT NO.
1240127001
 DRAWING NO.
C4.1
 SHEET 7 OF XX



PROFILE SCALE:
 HORIZONTAL: 1" = 20'
 VERTICAL: 1" = 4'

CONSTRUCTION NOTES

- (P) PROTECT EXISTING IMPROVEMENT IN PLACE.
- (LS) SEE PROPOSED LANDSCAPING IMPROVEMENT PLAN SHEETS XX-XX.
- (SL) SEE PROPOSED LIGHTING IMPROVEMENT PLAN SHEETS XX-XX.
- (1) CONSTRUCT 4-INCH FULL DEPTH ASPHALT CONCRETE, GRADE PG XX-XX OVER COMPACTED NATIVE TO 95% RELATIVE COMPACTION. SCARIFY AND RECOMPACT SUB BASE (6-IN MINIMUM).

REVISIONS NO.	DATE	INITIAL	DESCRIPTION
△			NOT FOR CONSTRUCTION
△			DRAFT SUBMITTAL

Harris & Associates

60 W Alisal Street, Suite 200, Salinas, CA 93901
 p. 831.233.9242 * WeAreHarris.com

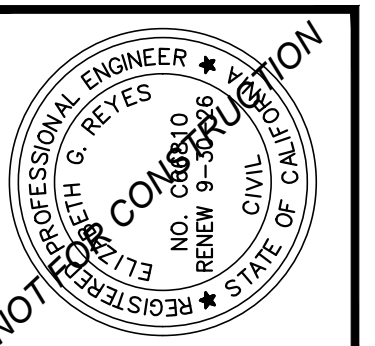
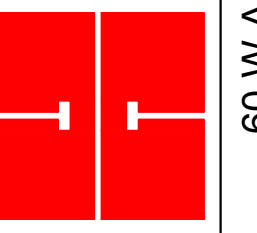

PROFILE

LEGEND

- PROPOSED ASPHALT CONCRETE PAVEMENT PER CN 1
- LANDSCAPE BUFFER (SEE LANDSCAPING PLANS SHEETS XX-XX)
- RIGHT OF WAY
- CITY LIMITS

CL CURVE AND LINE TABLE				
SEGMENT	LENGTH	BEARING	DELTA	RADIUS
C2	169.00'		2'06"06"	4607.00'
C3	174.19'		3'07"54"	3187.00'
C4	107.76'		7'15"19"	851.00'

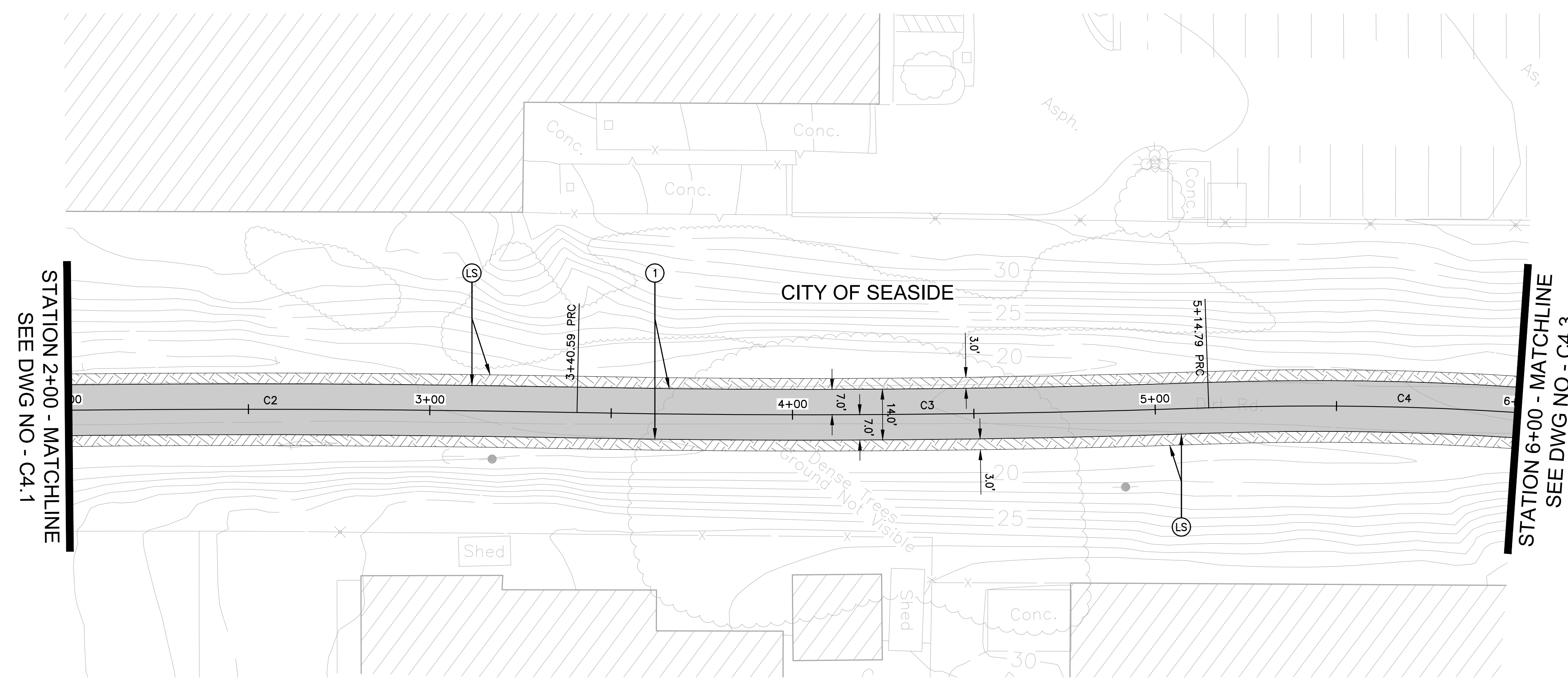

PLAN

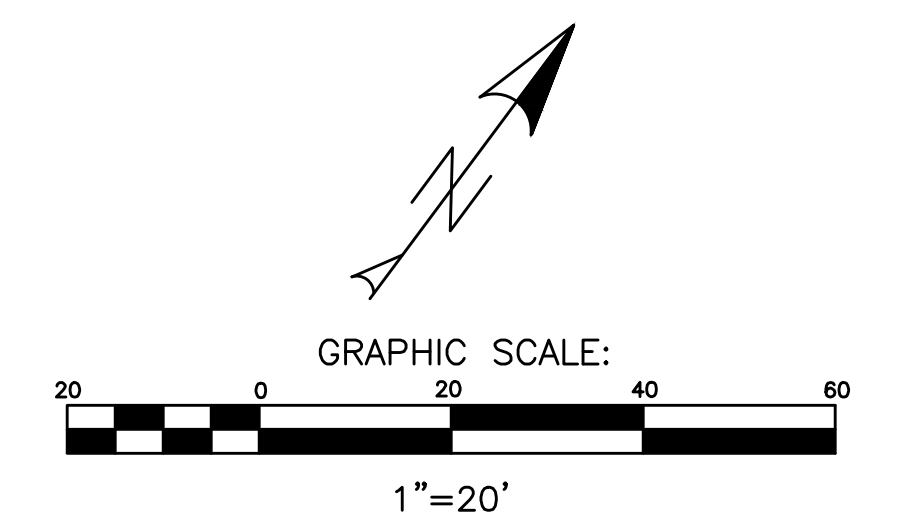

STATION 2+00 - MATCHLINE
SEE DWG NO - C4.1

STATION 6+00 - MATCHLINE
SEE DWG NO - C4.3

CITY OF SAND CITY
1 PENDERGRASS WAY, SAND CITY, CA 93955

PROJECT TITLE
MULTIUSE TRAIL PROJECT

SHEET DESCRIPTION
PLAN & PROFILE

DESIGNED BY:	IB
DATE:	5/15/25
SCALE:	AS NOTED
PROJECT NO.	1240127001
DRAWING NO.	C4.2
SHEET	8 OF XX



PROFILE SCALE:
 HORIZONTAL: 1" = 20'
 VERTICAL: 1" = 4'

CONSTRUCTION NOTES

- (P) PROTECT EXISTING IMPROVEMENT IN PLACE.
- (LS) SEE PROPOSED LANDSCAPING IMPROVEMENT PLAN SHEETS XX-XX.
- (SL) SEE PROPOSED LIGHTING IMPROVEMENT PLAN SHEETS XX-XX.
- (1) CONSTRUCT 4-INCH FULL DEPTH ASPHALT CONCRETE, GRADE PG XX-XX OVER COMPACTED NATIVE TO 95% RELATIVE COMPACTION. SCARIFY AND RECOMPACT SUB BASE (6-IN MINIMUM).

REVISIONS NO.	DATE	INITIAL	DESCRIPTION
△			NOT FOR CONSTRUCTION
△			DRAFT SUBMITTAL

Harris & Associates

60 W Alisal Street, Suite 200, Salinas, CA 93901
 p. 831.233.9242 * WeAreHarris.com

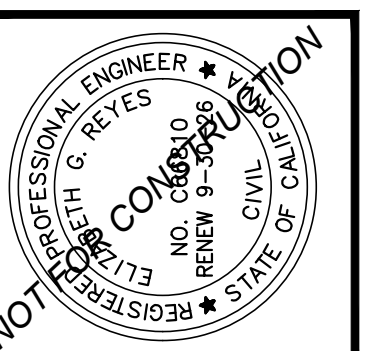
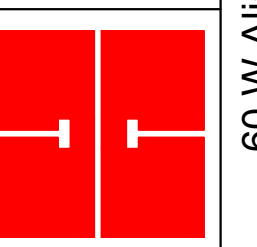

CITY OF SAND CITY
 1 PENDERGRASS WAY, SAND CITY, CA 93955
 PROJECT TITLE
 MULTIUSE TRAIL PROJECT
 SHEET DESCRIPTION
PLAN & PROFILE

DESIGNED BY: IB
 DATE: 5/15/25
 SCALE: AS NOTED
 PROJECT NO.
1240127001
 DRAWING NO.
C4.3
 SHEET 9 OF XX

PROFILE

LEGEND

- PROPOSED ASPHALT CONCRETE PAVEMENT PER CN 1
- LANDSCAPE BUFFER (SEE LANDSCAPING PLANS SHEETS XX-XX)
- RIGHT OF WAY
- CITY LIMITS

CL CURVE AND LINE TABLE				
SEGMENT	LENGTH	BEARING	DELTA	RADIUS
C4	107.76'		7°15'19"	851.00'
C5	39.98'		6°47'53"	337.00'
C6	63.67'		1°36'46"	2262.00'
C7	108.91'		5°36'23"	1113.00'
C8	89.17'		2°37'32"	1946.00'
C9	119.59'		0°32'42"	12570.00'
L3	13.58'	N58°35'22"E		

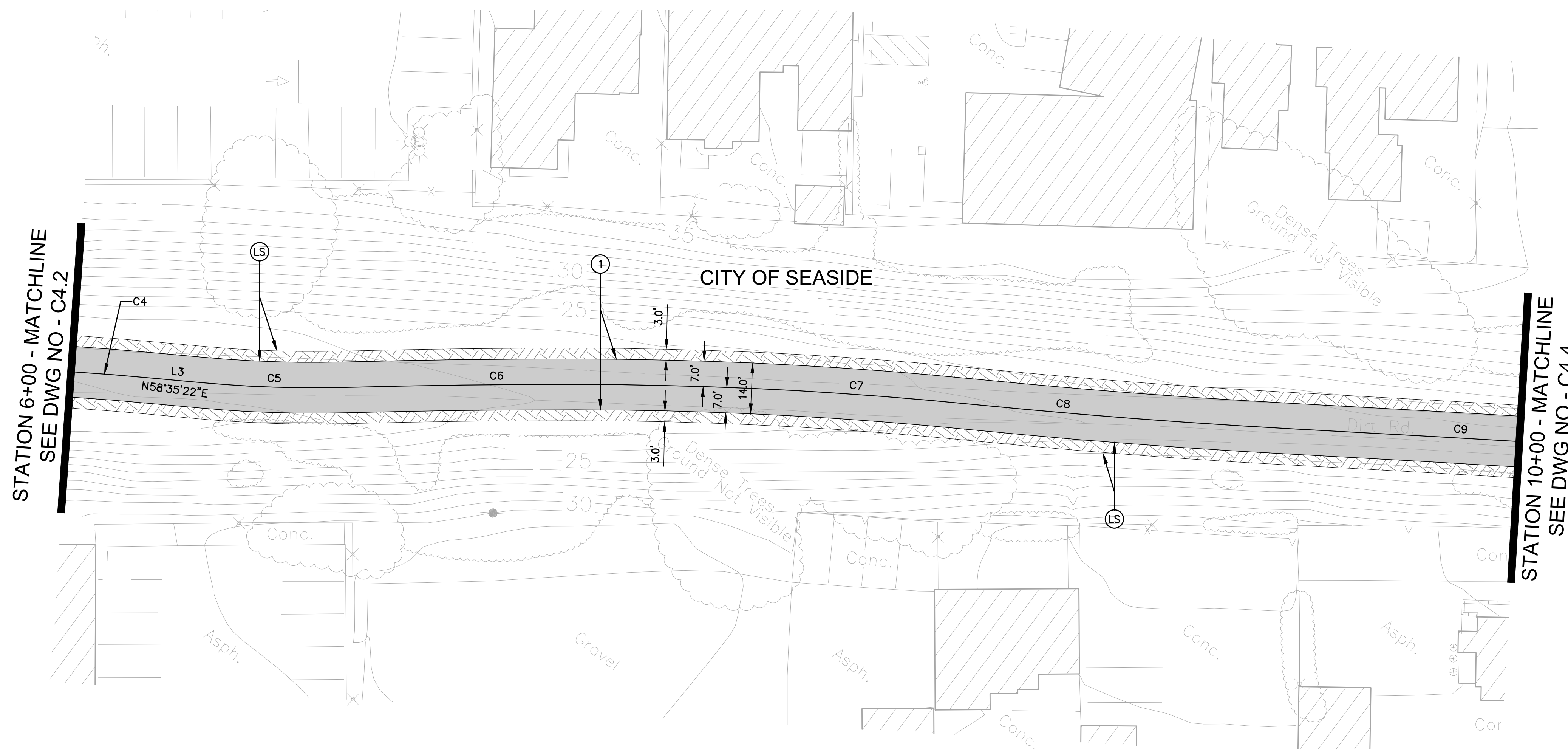
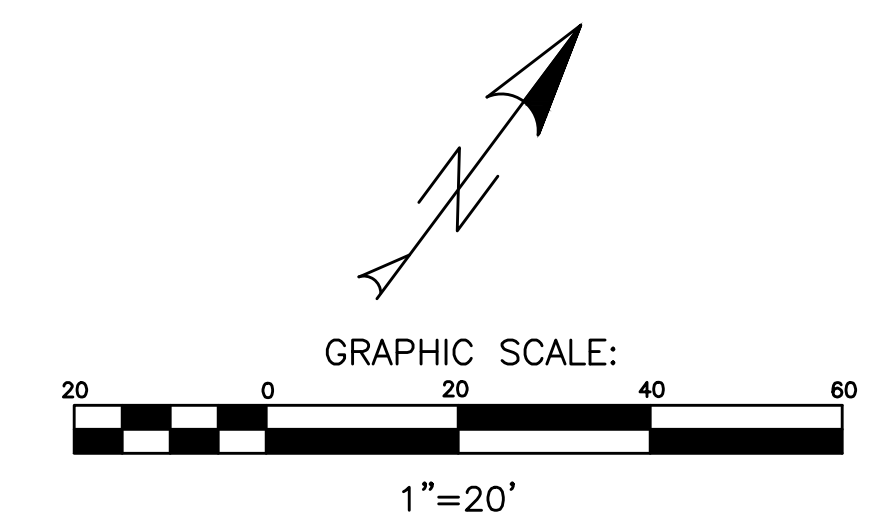

PLAN

STATION 6+00 - MATCHLINE
 SEE DWG NO - C4.2

STATION 10+00 - MATCHLINE
 SEE DWG NO - C4.4



PROFILE SCALE:
 HORIZONTAL: 1" = 20'
 VERTICAL: 1" = 4'

CONSTRUCTION NOTES

- (P) PROTECT EXISTING IMPROVEMENT IN PLACE.
- (LS) SEE PROPOSED LANDSCAPING IMPROVEMENT PLAN SHEETS XX-XX.
- (SL) SEE PROPOSED LIGHTING IMPROVEMENT PLAN SHEETS XX-XX.
- ① CONSTRUCT 4-INCH FULL DEPTH ASPHALT CONCRETE, GRADE PG XX-XX OVER COMPACTED NATIVE TO 95% RELATIVE COMPACTION. SCARIFY AND RECOMPACT SUB BASE (6-IN MINIMUM).
- ② CONSTRUCT RAISED CONCRETE CROSSWALK. SEE SIGNING AND STRIPING PLANS FOR CROSSWALK STRIPING DETAILS.

REVISIONS	NO.	DATE	INITIAL	DESCRIPTION
	△			NOT FOR CONSTRUCTION
	△			DRAFT SUBMITTAL

Harris & Associates
 60 W Alisal Street, Suite 200, Salinas, CA 93901
 p. 831.233.9242 * WeAreHarris.com

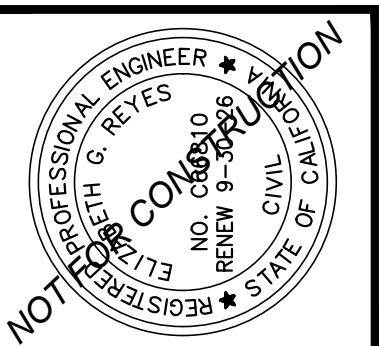

CITY OF SAND CITY
 1 PENDERGRASS WAY, SAND CITY, CA 93955
 PROJECT TITLE
 MULTIUSE TRAIL PROJECT
 SHEET DESCRIPTION
PLAN & PROFILE

DESIGNED BY: IB
 DATE: 5/15/25
 SCALE: AS NOTED
 PROJECT NO.
1240127001
 DRAWING NO.
C4.4
 SHEET 10 OF XX

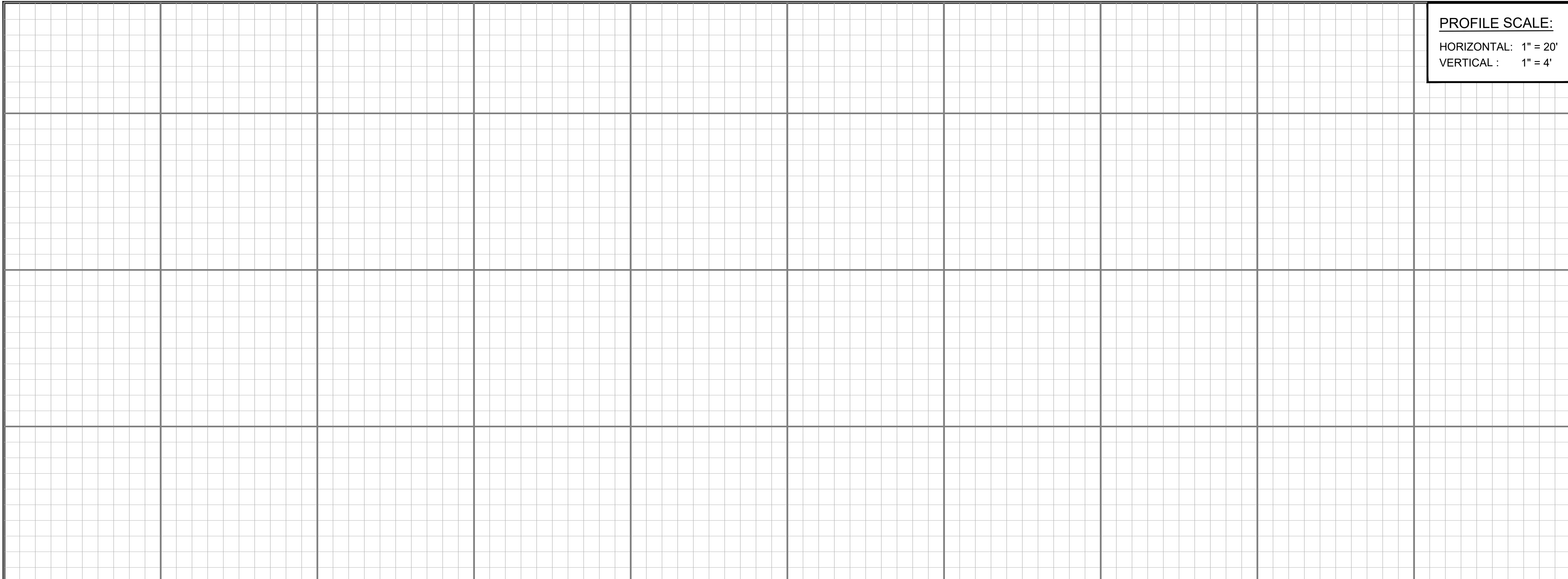

PROFILE

LEGEND

- PROPOSED ASPHALT CONCRETE PAVEMENT PER CN 1
- LANDSCAPE BUFFER (SEE LANDSCAPING PLANS SHEETS XX-XX)
- RIGHT OF WAY
- CITY LIMITS

CL CURVE AND LINE TABLE				
SEGMENT	LENGTH	BEARING	DELTA	RADIUS
C9	119.59'		0°32'42"	12570.00'
C10	30.97'		1°17'53"	1367.00'
C11	36.69'		22°36'06"	93.00'
C12	24.46'		77°50'37"	18.00'
C13	31.40'		89°56'50"	20.00'
C14	51.19'		83°47'44"	35.00'
L4	83.33'	N58°13'42"E		
L5	42.18'	N80°49'48"E		
L6	10.62'	N02°59'11"E		
L8	10.70'	N02°59'51"E		
L9	13.99'	S87°03'18"E		

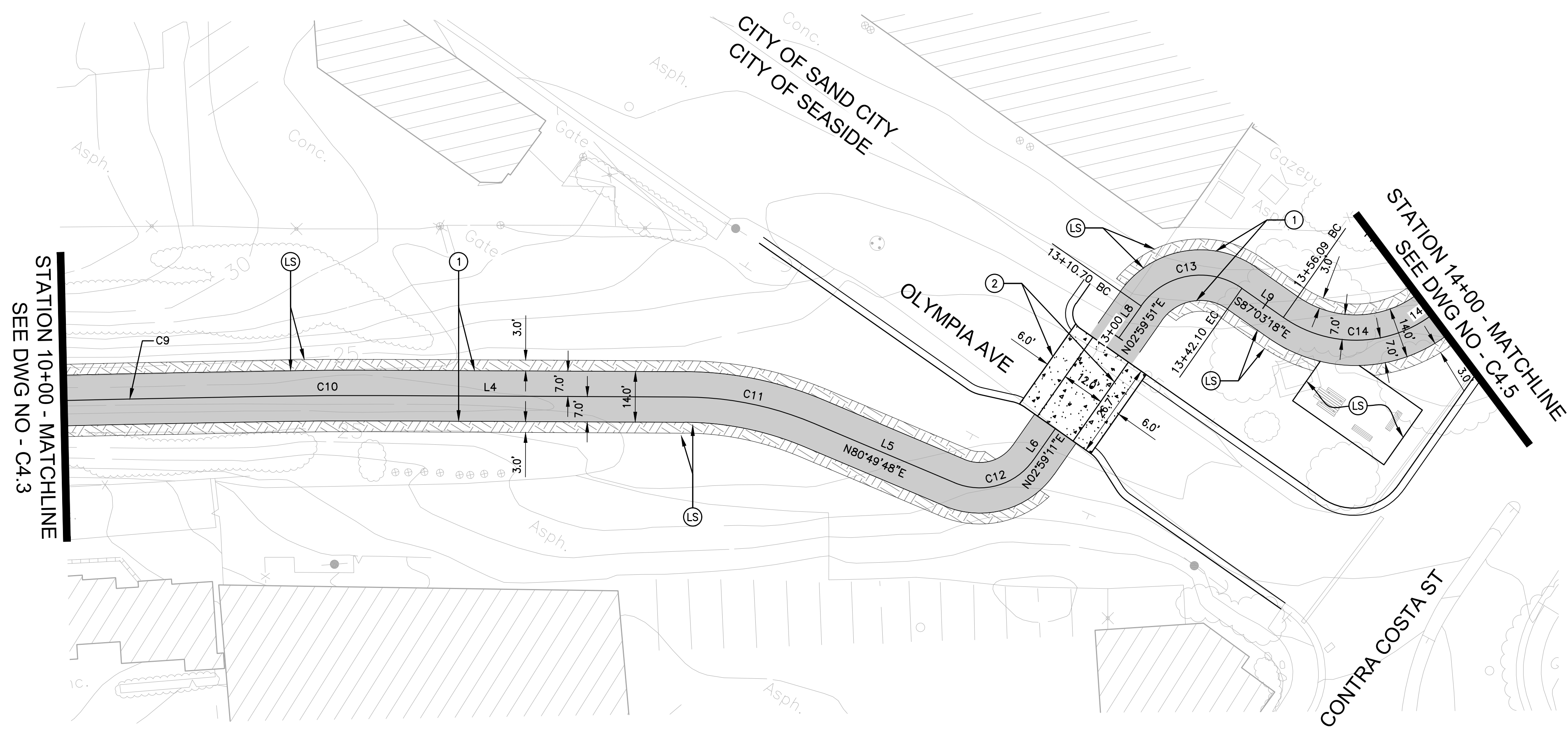

PLAN

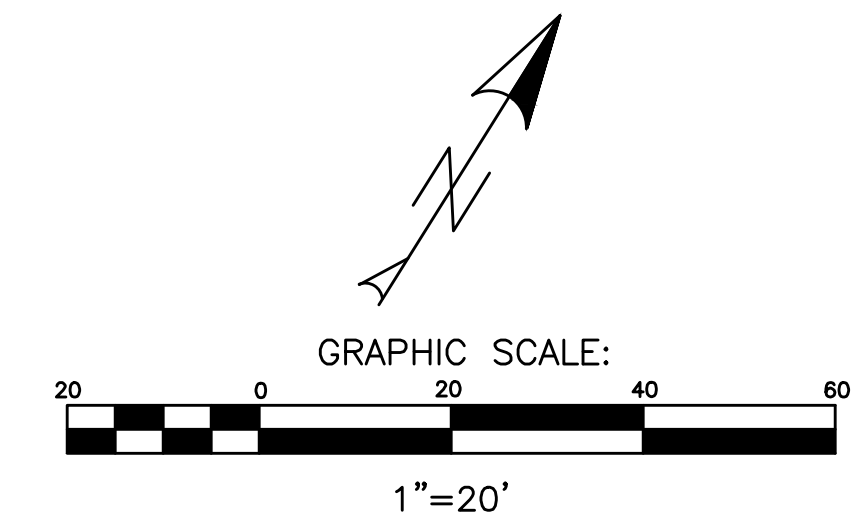



PROFILE SCALE:
 HORIZONTAL: 1" = 20'
 VERTICAL: 1" = 4'

CONSTRUCTION NOTES

- (P) PROTECT EXISTING IMPROVEMENT IN PLACE.
- (LS) SEE PROPOSED LANDSCAPING IMPROVEMENT PLAN SHEETS XX-XX.
- (SL) SEE PROPOSED LIGHTING IMPROVEMENT PLAN SHEETS XX-XX.
- (1) CONSTRUCT 4-INCH FULL DEPTH ASPHALT CONCRETE, GRADE PG XX-XX OVER COMPACTED NATIVE TO 95% RELATIVE COMPACTION. SCARIFY AND RECOMPACT SUB BASE (6-IN MINIMUM).

REVISIONS NO.	DATE	INITIAL	DESCRIPTION
△			NOT FOR CONSTRUCTION
△			DRAFT SUBMITTAL

Harris & Associates
 60 W Alisal Street, Suite 200, Salinas, CA 93901
 p. 831.233.9242 * WeAreHarris.com

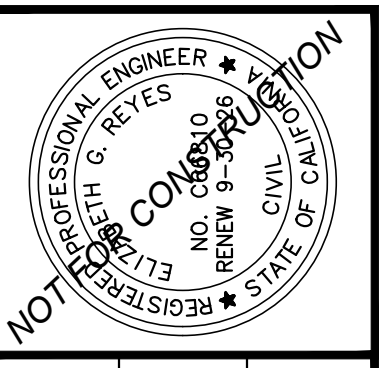

CITY OF SAND CITY
 1 PENDERGRASS WAY, SAND CITY, CA 93955
 PROJECT TITLE
 MULTIUSE TRAIL PROJECT
 SHEET DESCRIPTION
PLAN & PROFILE

DESIGNED BY: IB
 DATE: 5/15/25
 SCALE: AS NOTED
 PROJECT NO.
1240127001
 DRAWING NO.
C4.5
 SHEET 11 OF XX

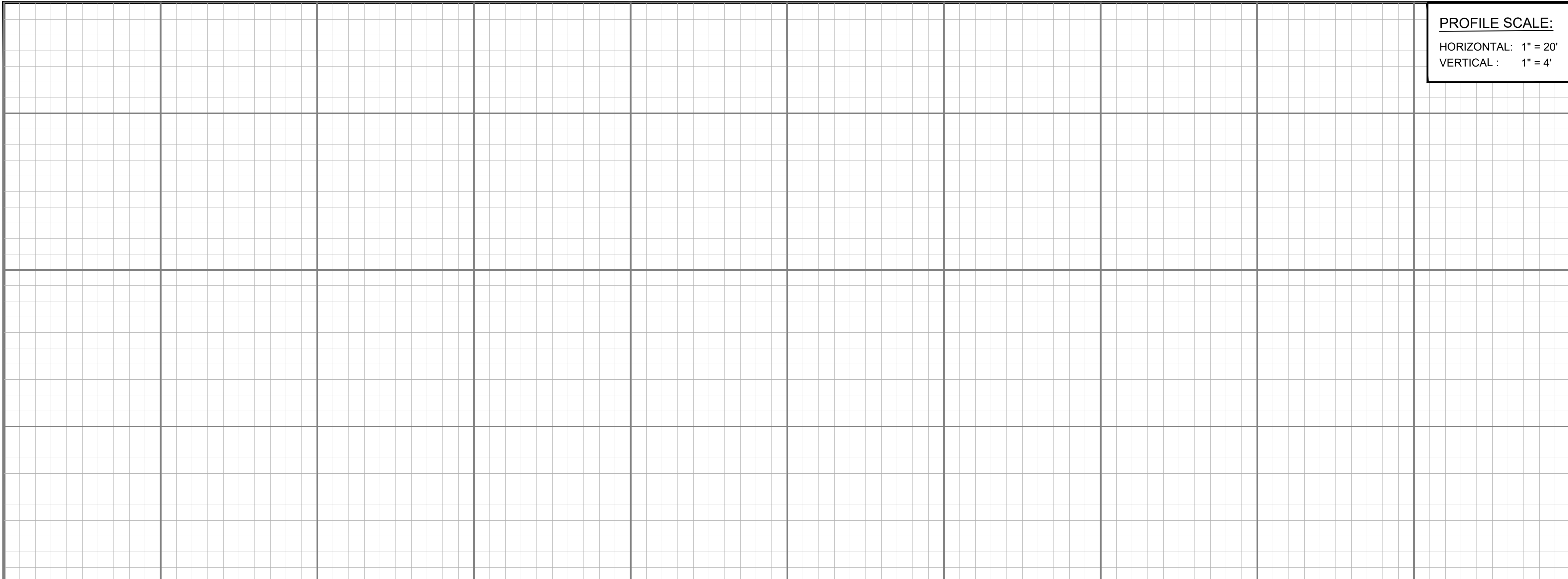

PROFILE

LEGEND

- PROPOSED ASPHALT CONCRETE PAVEMENT PER CN 1
- LANDSCAPE BUFFER (SEE LANDSCAPING PLANS SHEETS XX-XX)
- RIGHT OF WAY
- CITY LIMITS

CL CURVE AND LINE TABLE				
SEGMENT	LENGTH	BEARING	DELTA	RADIUS
C14	51.19'		83°47'44"	35.00'
C15	35.22'		80°42'40"	25.00'
C16	21.30'		34°51'58"	35.00'
C17	13.74'		22°30'00"	35.00'
C18	125.95'		33°15'21"	217.00'
C19	185.00'		17°24'20"	609.00'
C43	42.40'		4°06'37"	591.00'
C44	138.33'		13°17'55"	596.00'
L10	3.68'	N09°08'58"E		
L11	11.11'	N89°51'38"E		
L12	14.91'	S87°01'12"E		
L13	27.69'	N58°06'50"E		
L14	45.59'	N35°36'50"E		

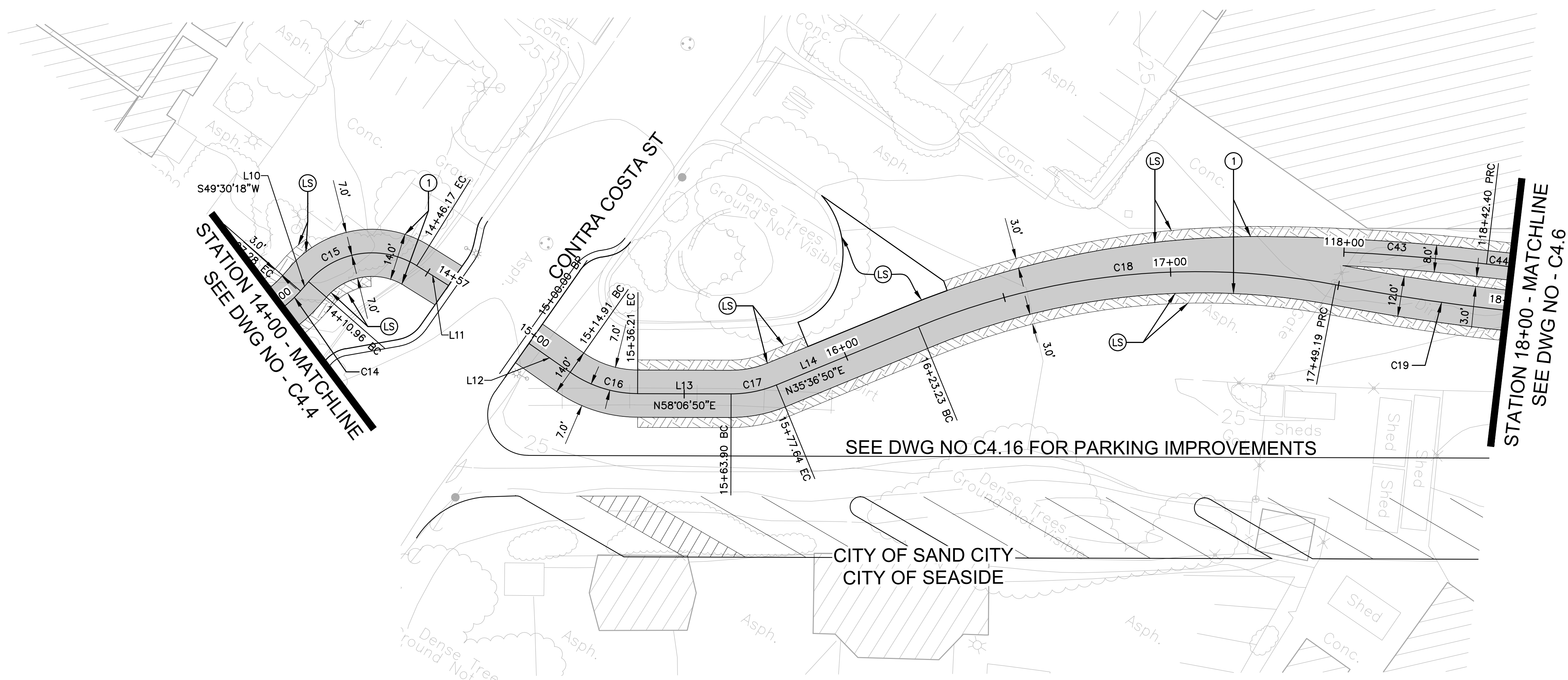

PLAN

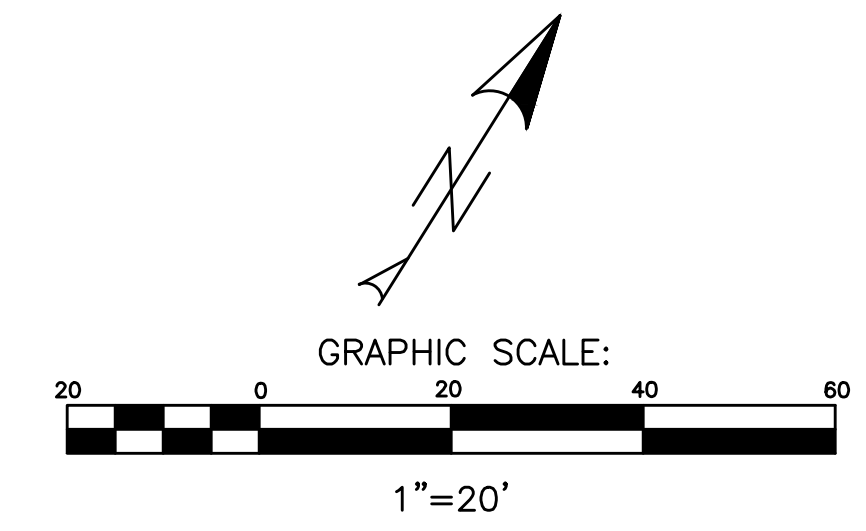



PROFILE SCALE:
 HORIZONTAL: 1" = 20'
 VERTICAL: 1" = 4'

CONSTRUCTION NOTES

- (P) PROTECT EXISTING IMPROVEMENT IN PLACE.
- (LS) SEE PROPOSED LANDSCAPING IMPROVEMENT PLAN SHEETS XX-XX.
- (SL) SEE PROPOSED LIGHTING IMPROVEMENT PLAN SHEETS XX-XX.
- (1) CONSTRUCT 4-INCH FULL DEPTH ASPHALT CONCRETE, GRADE PG XX-XX OVER COMPACTED NATIVE TO 95% RELATIVE COMPACTION. SCARIFY AND RECOMPACT SUB BASE (6-IN MINIMUM).

REVISIONS	NO.	DATE	INITIAL	DESCRIPTION
	1			NOT FOR CONSTRUCTION
	2			DRAFT SUBMITTAL

Harris & Associates
 60 W Alisal Street, Suite 200, Salinas, CA 93901
 p. 831.233.9242 * WeAreHarris.com

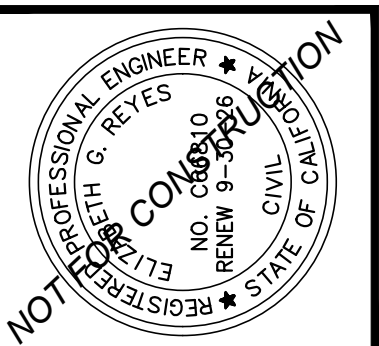

CITY OF SAND CITY
 1 PENDERGRASS WAY, SAND CITY, CA 93955
 PROJECT TITLE
 MULTIUSE TRAIL PROJECT
 SHEET DESCRIPTION
PLAN & PROFILE

DESIGNED BY: IB
 DATE: 5/15/25
 SCALE: AS NOTED
 PROJECT NO.
1240127001
 DRAWING NO.
C4.6
 SHEET 12 OF XX

PROFILE

LEGEND

- PROPOSED ASPHALT CONCRETE PAVEMENT PER CN 1
- LANDSCAPE BUFFER (SEE LANDSCAPING PLANS SHEETS XX-XX)
- RIGHT OF WAY
- CITY LIMITS

CL CURVE AND LINE TABLE				
SEGMENT	LENGTH	BEARING	DELTA	RADIUS
C19	185.00'		17°24'20"	609.00'
C20	133.54'		13°18'24"	575.00'
C21	141.44'		13°18'23"	609.00'
C44	138.33'		13°17'55"	596.00'
C45	136.56'		13°18'24"	588.00'
C46	138.42'		13°18'23"	596.00'

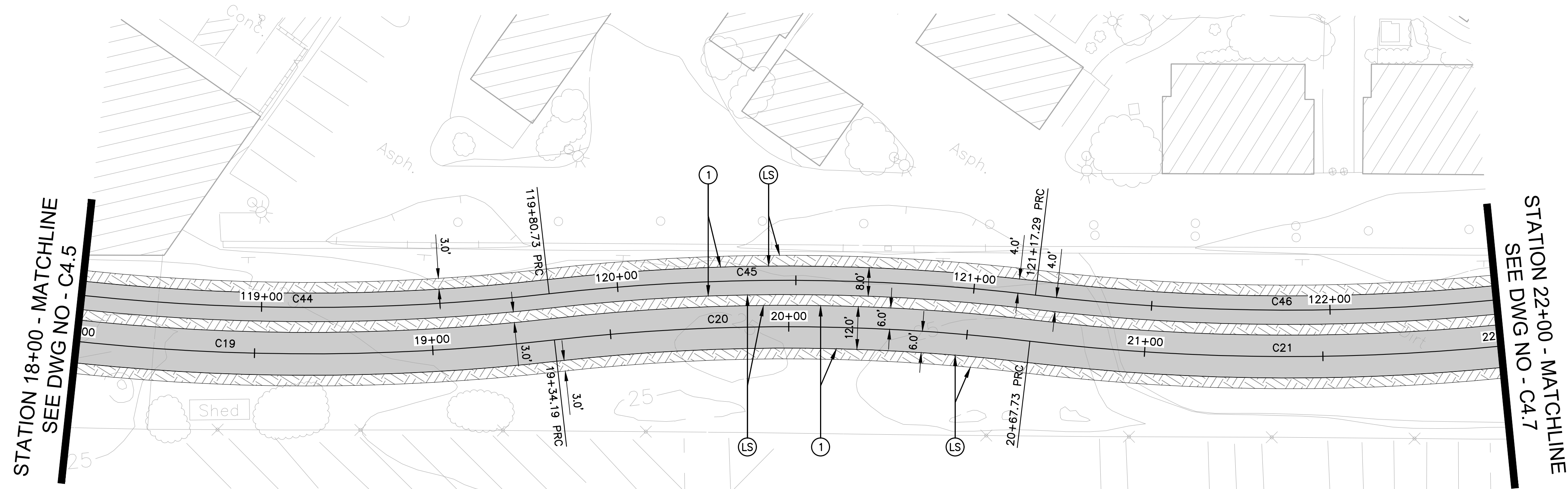

SEE DWG NO C4.16 FOR PARKING IMPROVEMENTS

PLAN

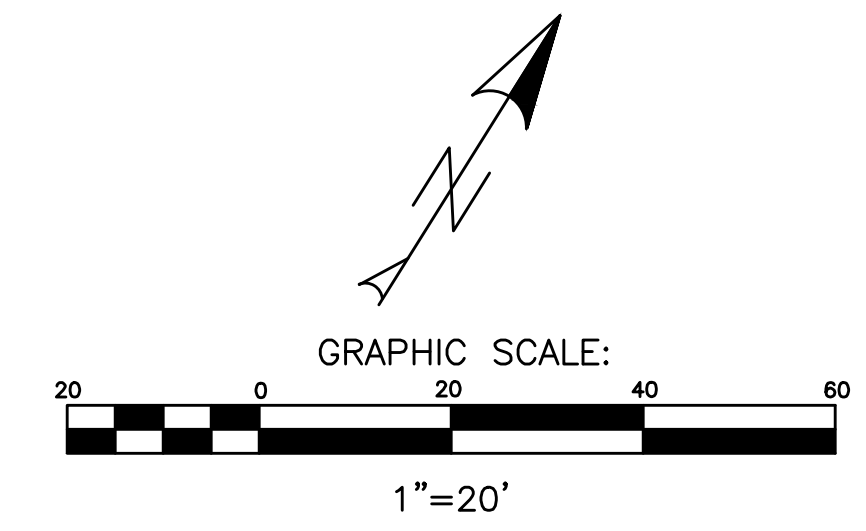
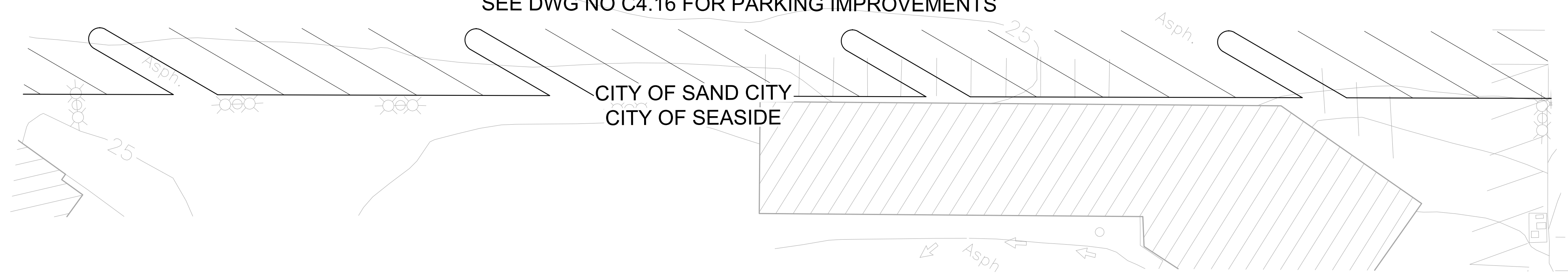

PROFILE SCALE:
 HORIZONTAL: 1" = 20'
 VERTICAL: 1" = 4'

CONSTRUCTION NOTES

- (P) PROTECT EXISTING IMPROVEMENT IN PLACE.
- (LS) SEE PROPOSED LANDSCAPING IMPROVEMENT PLAN SHEETS XX-XX.
- (SL) SEE PROPOSED LIGHTING IMPROVEMENT PLAN SHEETS XX-XX.
- (1) CONSTRUCT 4-INCH FULL DEPTH ASPHALT CONCRETE, GRADE PG XX-XX OVER COMPACTED NATIVE TO 95% RELATIVE COMPACTION. SCARIFY AND RECOMPACT SUB BASE (6-IN MINIMUM).



REVISIONS NO.	DATE	INITIAL	DESCRIPTION
△			NOT FOR CONSTRUCTION
△			DRAFT SUBMITTAL

Harris & Associates
 60 W Alisal Street, Suite 200, Salinas, CA 93901
 p. 831.233.9242 * WeAreHarris.com

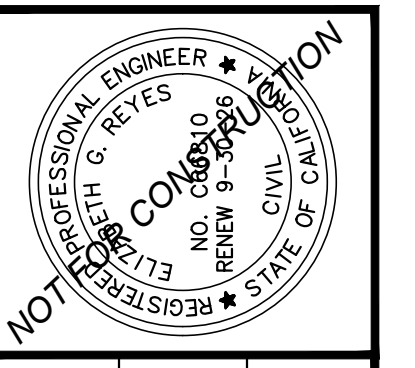

CITY OF SAND CITY
 1 PENDERGRASS WAY, SAND CITY, CA 93955
 PROJECT TITLE
 MULTITUDE TRAIL PROJECT
 SHEET DESCRIPTION
PLAN & PROFILE

DESIGNED BY: IB
 DATE: 5/15/25
 SCALE: AS NOTED
 PROJECT NO.
1240127001
 DRAWING NO.
C4.7
 SHEET 13 OF XX

PROFILE

PLAN

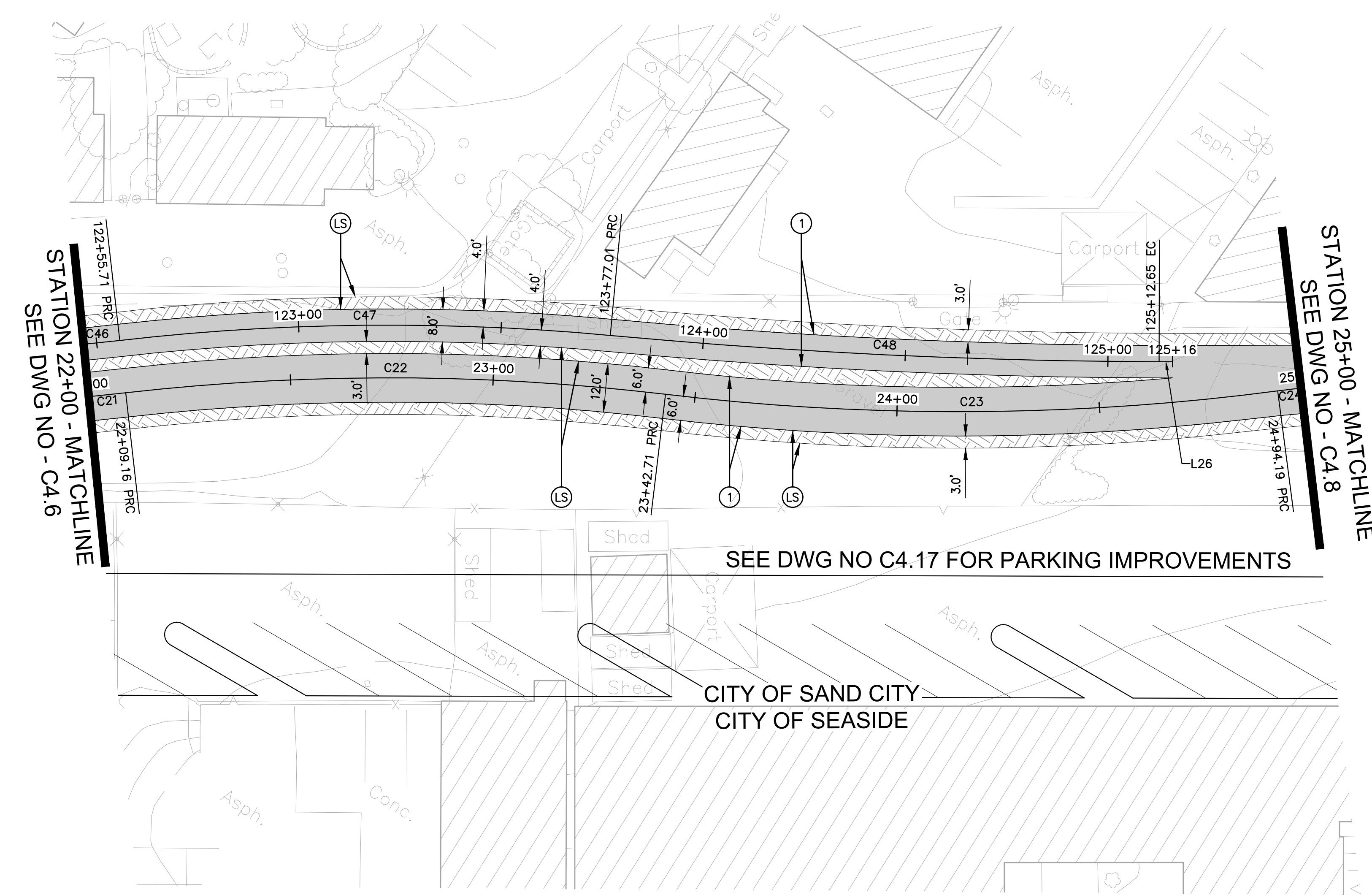

LEGEND

- PROPOSED ASPHALT CONCRETE PAVEMENT PER CN 1
- LANDSCAPE BUFFER (SEE LANDSCAPING PLANS SHEETS XX-XX)
- RIGHT OF WAY
- CITY LIMITS

CL CURVE AND LINE TABLE				
SEGMENT	LENGTH	BEARING	DELTA	RADIUS
C21	141.44'		13°18'23"	609.00'
C22	133.54'		13°18'24"	575.00'
C23	151.48'		14°15'06"	609.00'
C24	62.33'		7°35'52"	470.00'
C46	138.42'		13°18'23"	596.00'
C47	121.31'		11°49'13"	588.00'
C48	135.64'		5°10'02"	1504.00'
L26	3.33'	N58°07'03"E		

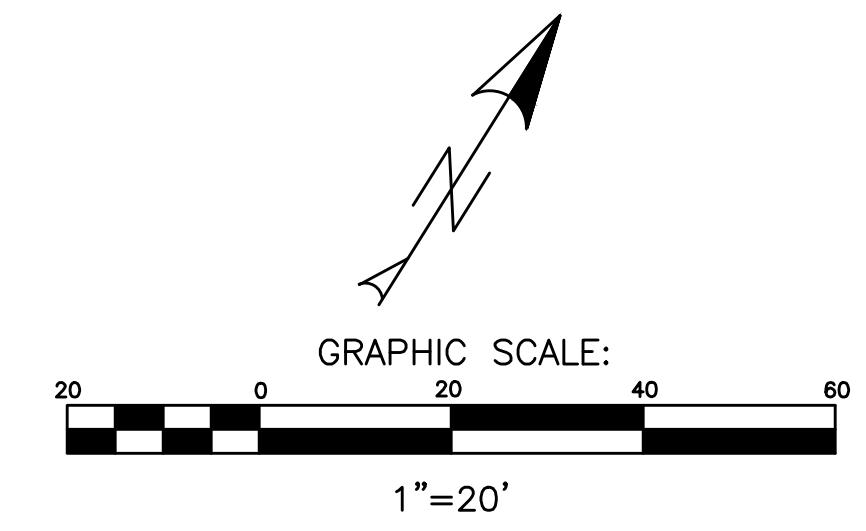

PROFILE SCALE:
 HORIZONTAL: 1" = 20'
 VERTICAL: 1" = 4'

CONSTRUCTION NOTES

- (P) PROTECT EXISTING IMPROVEMENT IN PLACE.
- (LS) SEE PROPOSED LANDSCAPING IMPROVEMENT PLAN SHEETS XX-XX.
- (SL) SEE PROPOSED LIGHTING IMPROVEMENT PLAN SHEETS XX-XX.
- ① CONSTRUCT 4-INCH FULL DEPTH ASPHALT CONCRETE, GRADE PG XX-XX OVER COMPACTED NATIVE TO 95% RELATIVE COMPACTION. SCARIFY AND RECOMPACT SUB BASE (6-IN MINIMUM).
- ② CONSTRUCT RAISED CONCRETE CROSSWALK. SEE SIGNING AND STRIPING PLANS FOR CROSSWALK STRIPING DETAILS.



REVISIONS NO.	DATE	INITIAL	DESCRIPTION
△			NOT FOR CONSTRUCTION
△			DRAFT SUBMITTAL

Harris & Associates
 60 W Alisal Street, Suite 200, Salinas, CA 93901
 p. 831.233.9242 * WeAreHarris.com

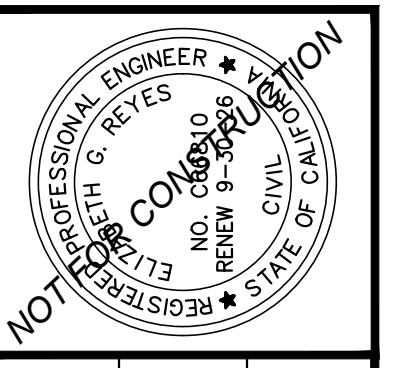

CITY OF SAND CITY
 1 PENDERGRASS WAY, SAND CITY, CA 93955
 PROJECT TITLE
 MULTITUDE TRAIL PROJECT
 SHEET DESCRIPTION
PLAN & PROFILE

DESIGNED BY: IB
 DATE: 5/15/25
 SCALE: AS NOTED
 PROJECT NO.
 1240127001
 DRAWING NO.
C4.8
 SHEET 14 OF XX

PROFILE

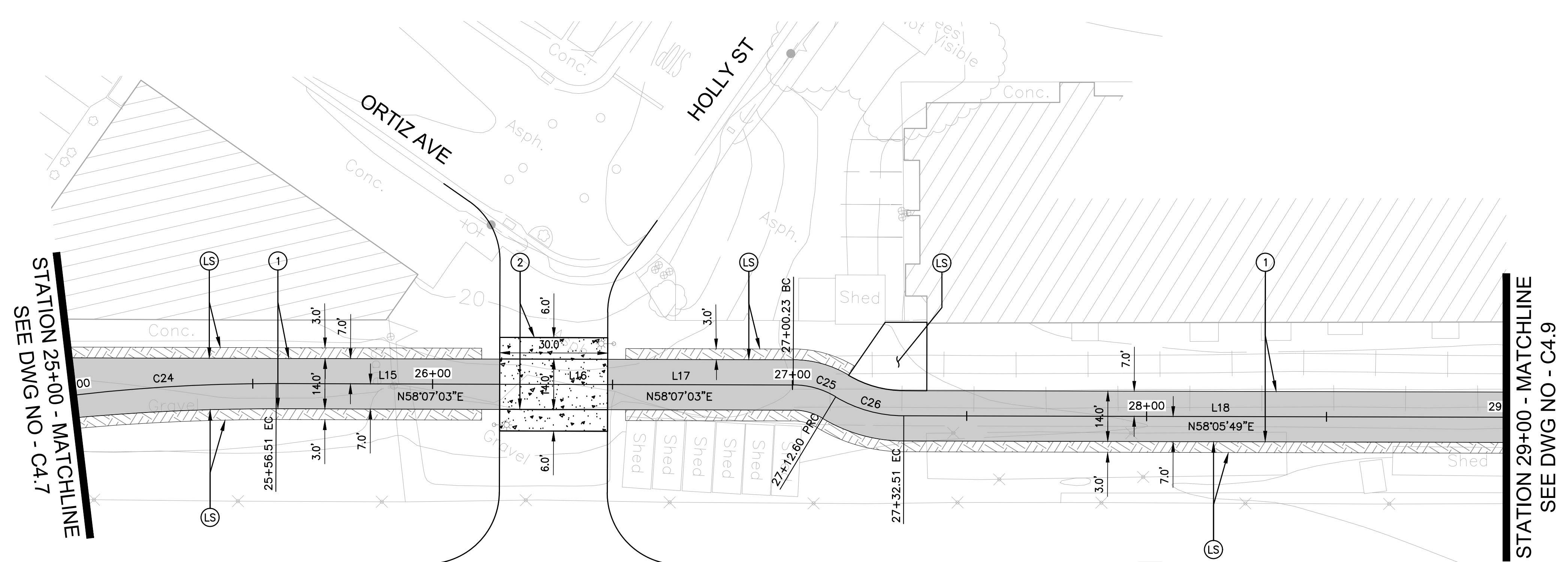

STATION 25+00 - MATCHLINE
 SEE DWG NO - C4.7

STATION 29+00 - MATCHLINE
 SEE DWG NO - C4.9

SEE DWG NO C4.17 FOR PARKING IMPROVEMENTS

PLAN

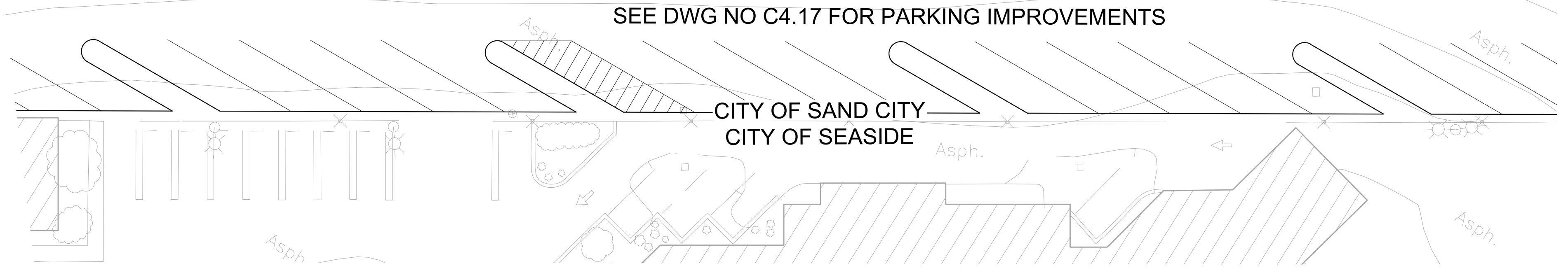

LEGEND

- PROPOSED ASPHALT CONCRETE PAVEMENT PER CN 1
- LANDSCAPE BUFFER (SEE LANDSCAPING PLANS SHEETS XX-XX)
- RIGHT OF WAY
- CITY LIMITS

CL CURVE AND LINE TABLE				
SEGMENT	LENGTH	BEARING	DELTA	RADIUS
C24	62.33'		7°35'52"	470.00'
C25	12.37'		30°48'56"	23.00'
C26	19.91'		30°50'09"	37.00'
L15	62.13'	N58°07'03"E		
L16	30.00'	N58°07'03"E		
L17	51.58'	N58°07'03"E		
L18	200.28'	N58°05'49"E		

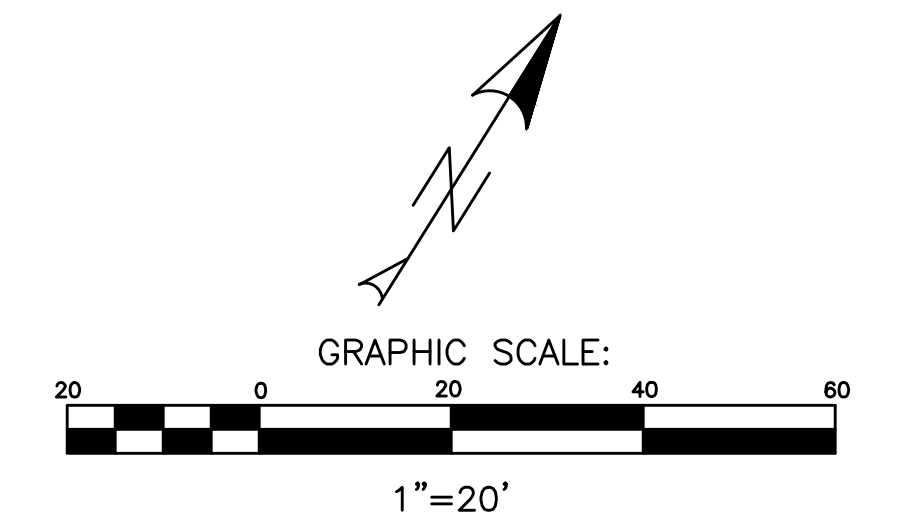



PROFILE SCALE:
 HORIZONTAL: 1" = 20'
 VERTICAL: 1" = 4'

CONSTRUCTION NOTES

- (P) PROTECT EXISTING IMPROVEMENT IN PLACE.
- (LS) SEE PROPOSED LANDSCAPING IMPROVEMENT PLAN SHEETS XX-XX.
- (SL) SEE PROPOSED LIGHTING IMPROVEMENT PLAN SHEETS XX-XX.
- ① CONSTRUCT 4-INCH FULL DEPTH ASPHALT CONCRETE, GRADE PG XX-XX OVER COMPACTED NATIVE TO 95% RELATIVE COMPACTION. SCARIFY AND RECOMPACT SUB BASE (6-IN MINIMUM).
- ② CONSTRUCT RAISED CONCRETE CROSSWALK. SEE SIGNING AND STRIPING PLANS FOR CROSSWALK STRIPING DETAILS.

REVISIONS NO.	DATE	INITIAL	DESCRIPTION
△			NOT FOR CONSTRUCTION
△			DRAFT SUBMITTAL

Harris & Associates
 60 W Alisal Street, Suite 200, Salinas, CA 93901
 p. 831.233.9242 * WeAreHarris.com

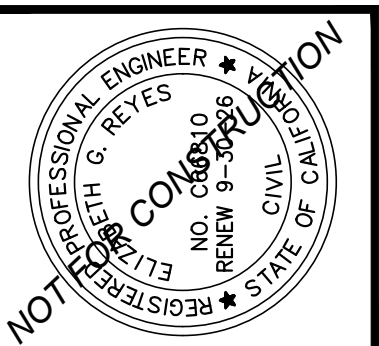

CITY OF SAND CITY
 1 PENDERGRASS WAY, SAND CITY, CA 93955
 PROJECT TITLE
 MULTIUSE TRAIL PROJECT
 SHEET DESCRIPTION
PLAN & PROFILE

DESIGNED BY: IB
 DATE: 5/15/25
 SCALE: AS NOTED
 PROJECT NO.
1240127001
 DRAWING NO.
C4.9
 SHEET 15 OF XX

PROFILE

PLAN

LEGEND

- PROPOSED ASPHALT CONCRETE PAVEMENT PER CN 1
- LANDSCAPE BUFFER (SEE LANDSCAPING PLANS SHEETS XX-XX)
- RIGHT OF WAY
- CITY LIMITS

CL CURVE AND LINE TABLE				
SEGMENT	LENGTH	BEARING	DELTA	RADIUS
C27	19.93'		30°52'11"	37.00'
C28	12.38'		30°50'34"	23.00'
C29	31.79'		10°07'05"	180.00'
C30	43.64'		12°08'16"	206.00'
C31	147.06'		18°33'36"	454.00'
C49	29.12'		11°25'36"	146.00'
C50	126.12'		16°20'56"	442.00'
L18	200.28'	N58°05'49"E		
L19	51.59'	N58°04'12"E		
L20	30.00'	N58°06'19"E		
L21	50.02'	N58°06'19"E		

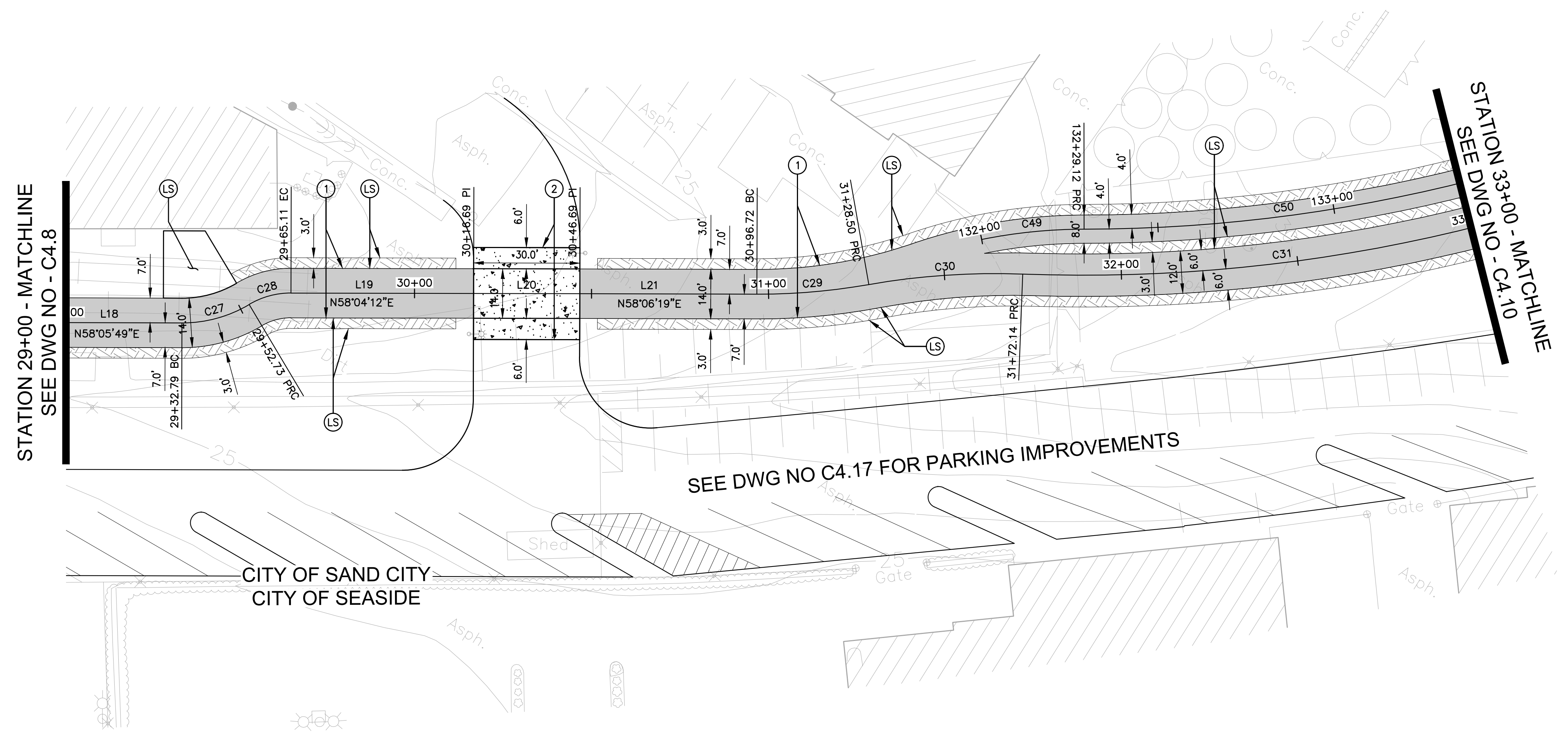
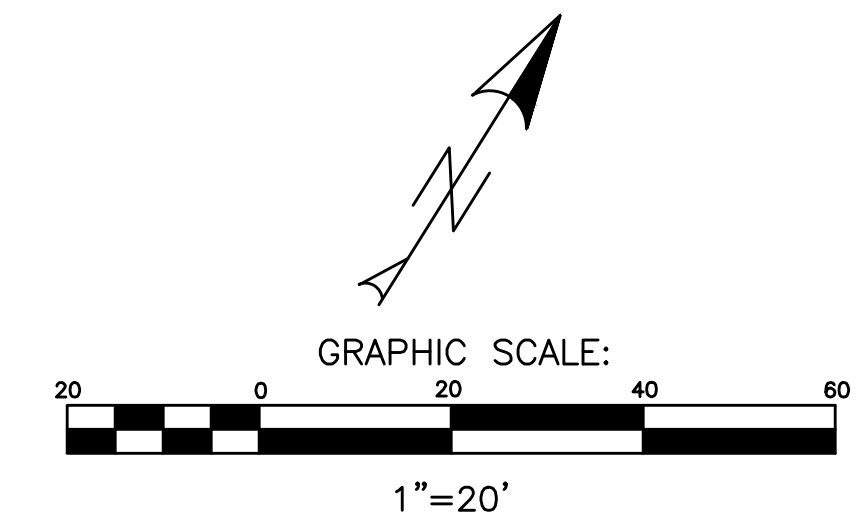

STATION 29+00 - MATCHLINE
 SEE DWG NO - C4.8

STATION 33+00 - MATCHLINE
 SEE DWG NO - C4.10

CITY OF SAND CITY
 CITY OF SEASIDE



PROFILE SCALE:
 HORIZONTAL: 1" = 20'
 VERTICAL: 1" = 4'

CONSTRUCTION NOTES

- (P) PROTECT EXISTING IMPROVEMENT IN PLACE.
- (LS) SEE PROPOSED LANDSCAPING IMPROVEMENT PLAN SHEETS XX-XX.
- (SL) SEE PROPOSED LIGHTING IMPROVEMENT PLAN SHEETS XX-XX.
- (1) CONSTRUCT 4-INCH FULL DEPTH ASPHALT CONCRETE, GRADE PG XX-XX OVER COMPACTED NATIVE TO 95% RELATIVE COMPACTION. SCARIFY AND RECOMPACT SUB BASE (6-IN MINIMUM).

REVISIONS	NO.	DATE	INITIAL	DESCRIPTION
	1			NOT FOR CONSTRUCTION
	2			DRAFT SUBMITTAL

Harris & Associates

60 W Alisal Street, Suite 200, Salinas, CA 93901
 p. 831.233.9242
 WeAreHarris.com

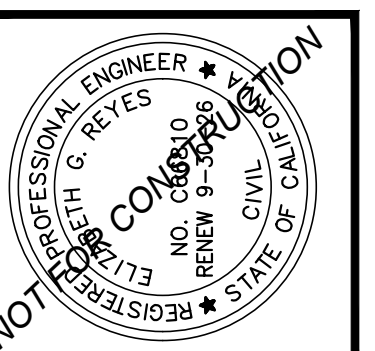
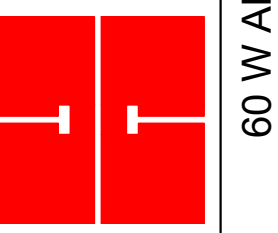

PROFILE

LEGEND

- PROPOSED ASPHALT CONCRETE PAVEMENT PER CN 1
- LANDSCAPE BUFFER (SEE LANDSCAPING PLANS SHEETS XX-XX)
- RIGHT OF WAY
- CITY LIMITS

CL CURVE AND LINE TABLE				
SEGMENT	LENGTH	BEARING	DELTA	RADIUS
C31	147.06'		18°33'36"	454.00'
C32	136.19'		9°11'27"	849.00'
C33	139.33'		17°32'44"	455.00'
C34	136.09'		9°11'03"	849.00'
C50	126.12'		16°20'56"	442.00'
C51	138.17'		9°11'02"	862.00'
C52	135.35'		17°32'44"	442.00'
C53	138.17'		9°11'03"	862.00'

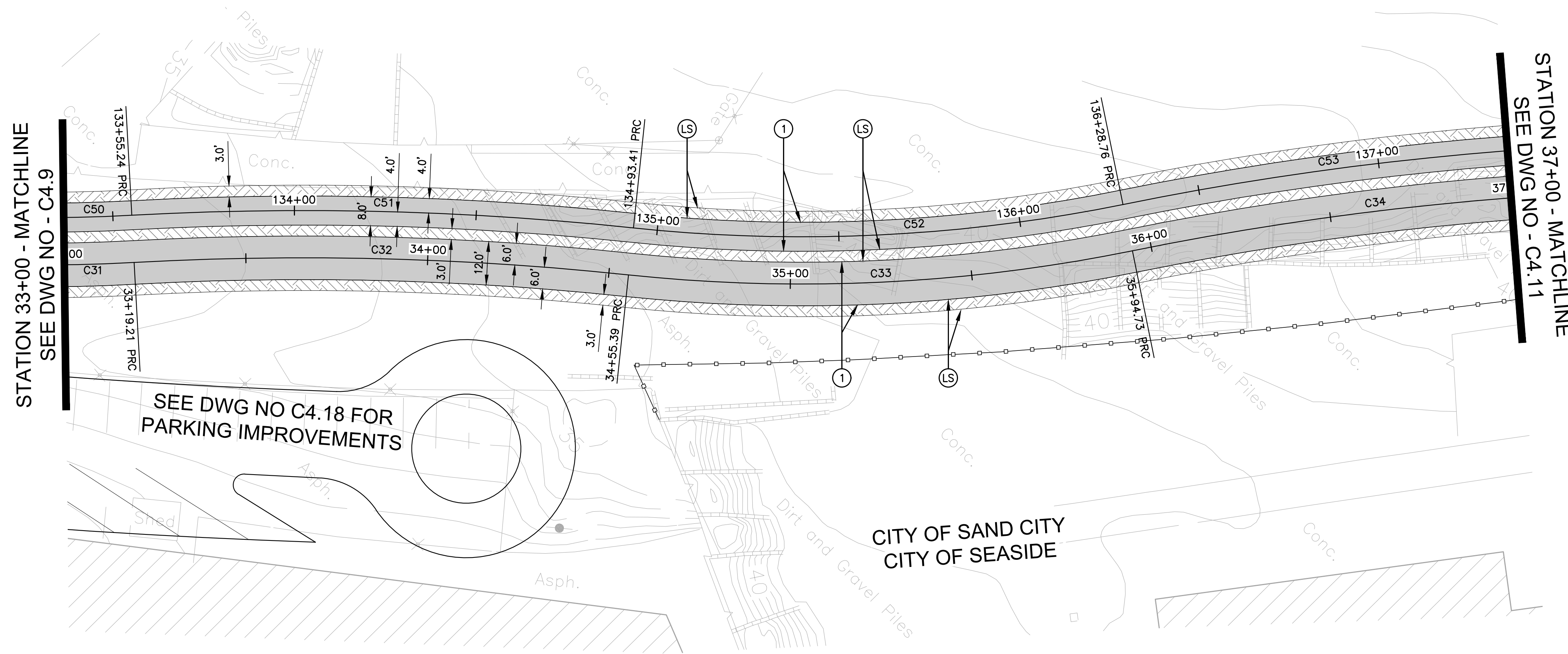

PLAN

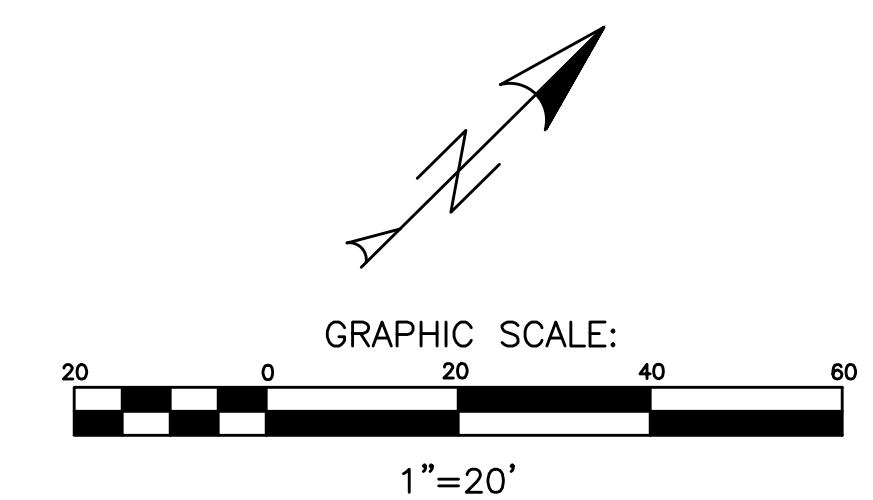

CITY OF SAND CITY

1 PENDERGRASS WAY, SAND CITY, CA 93955
 PROJECT TITLE
 MULTIUSE TRAIL PROJECT

SHEET DESCRIPTION
PLAN & PROFILE

DESIGNED BY: IB
 DATE: 5/15/25
 SCALE: AS NOTED
 PROJECT NO.
1240127001
 DRAWING NO.
C4.10
 SHEET 16 OF XX

PROFILE SCALE:
 HORIZONTAL: 1" = 20'
 VERTICAL: 1" = 4'

CONSTRUCTION NOTES

- (P) PROTECT EXISTING IMPROVEMENT IN PLACE.
- (LS) SEE PROPOSED LANDSCAPING IMPROVEMENT PLAN SHEETS XX-XX.
- (SL) SEE PROPOSED LIGHTING IMPROVEMENT PLAN SHEETS XX-XX.
- (1) CONSTRUCT 4-INCH FULL DEPTH ASPHALT CONCRETE, GRADE PG XX-XX OVER COMPACTED NATIVE TO 95% RELATIVE COMPACTION. SCARIFY AND RECOMPACT SUB BASE (6-IN MINIMUM).



REVISIONS NO.	DATE	INITIAL	DESCRIPTION
△			NOT FOR CONSTRUCTION
△			DRAFT SUBMITTAL

Harris & Associates
 60 W Alisal Street, Suite 200, Salinas, CA 93901
 p. 831.233.9242 * WeAreHarris.com

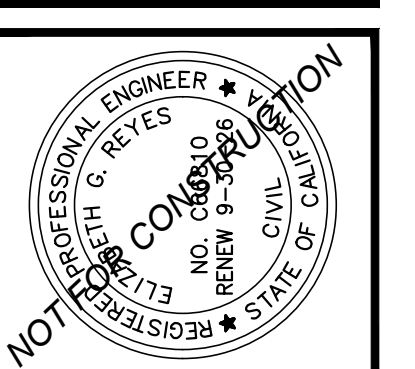

CITY OF SAND CITY
 1 PENDERGRASS WAY, SAND CITY, CA 93955
 PROJECT TITLE
 MULTIUSE TRAIL PROJECT
 SHEET DESCRIPTION
PLAN & PROFILE

DESIGNED BY: IB
 DATE: 5/15/25
 SCALE: AS NOTED
 PROJECT NO.
 1240127001
 DRAWING NO.
C4.11
 SHEET 17 OF XX

PROFILE

PLAN

LEGEND

- PROPOSED ASPHALT CONCRETE PAVEMENT PER CN 1
- LANDSCAPE BUFFER (SEE LANDSCAPING PLANS SHEETS XX-XX)
- RIGHT OF WAY
- CITY LIMITS

CL CURVE AND LINE TABLE				
SEGMENT	LENGTH	BEARING	DELTA	RADIUS
C34	136.09'		9°11'03"	849.00'
C35	172.90'		21°46'19"	455.00'
C36	37.02'		60°36'25"	35.00'
C37	33.63'		55°03'36"	35.00'
C53	138.17'		9°11'03"	862.00'
C54	135.36'		17°32'50"	442.00'
C55	31.17'		2°04'19"	862.00'
C56	9.59'		11°41'13"	47.00'
L22	60.37'	N81°13'46"E		
L23	64.27'	N26°10'10"E		

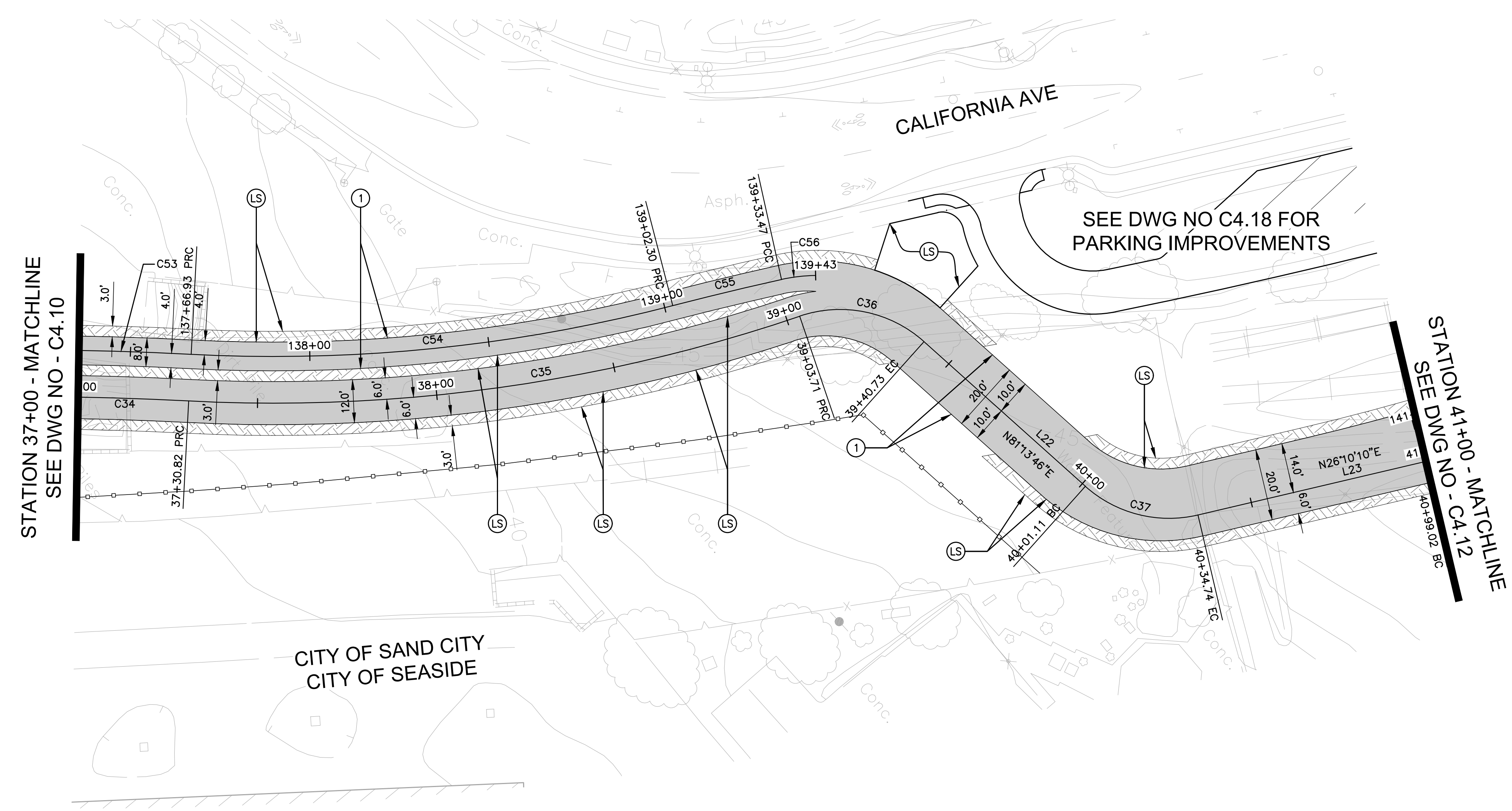
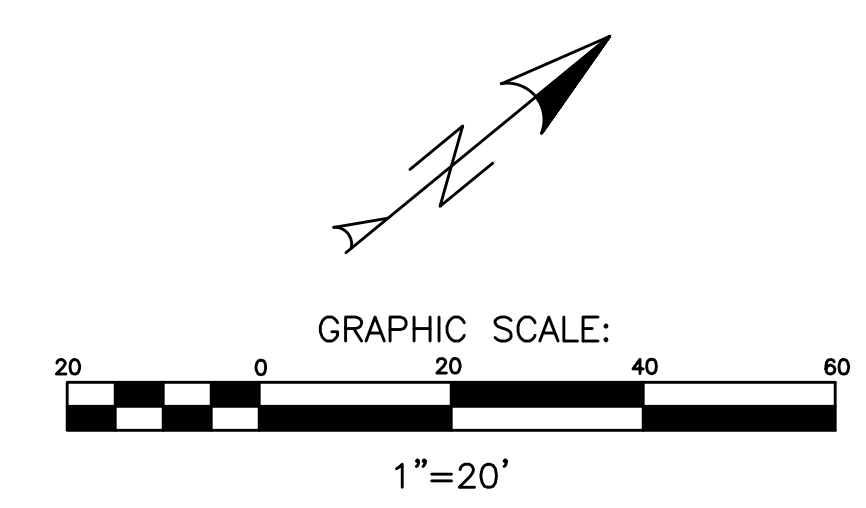



PROFILE SCALE:
 HORIZONTAL: 1" = 20'
 VERTICAL: 1" = 4'

CONSTRUCTION NOTES

- (P) PROTECT EXISTING IMPROVEMENT IN PLACE.
- (LS) SEE PROPOSED LANDSCAPING IMPROVEMENT PLAN SHEETS XX-XX.
- (SL) SEE PROPOSED LIGHTING IMPROVEMENT PLAN SHEETS XX-XX.
- (1) CONSTRUCT 4-INCH FULL DEPTH ASPHALT CONCRETE, GRADE PG XX-XX OVER COMPACTED NATIVE TO 95% RELATIVE COMPACTION. SCARIFY AND RECOMPACT SUB BASE (6-IN MINIMUM).

REVISIONS NO.	DATE	INITIAL	DESCRIPTION
△			NOT FOR CONSTRUCTION
△			DRAFT SUBMITTAL

Harris & Associates
 60 W Alisal Street, Suite 200, Salinas, CA 93901
 p. 831.233.9242 * WeAreHarris.com

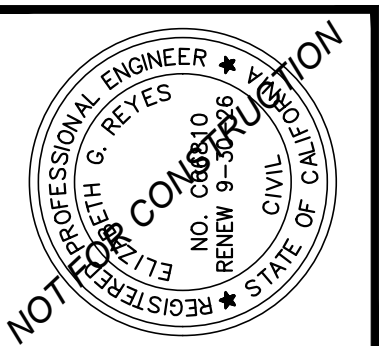

CITY OF SAND CITY
 1 PENDERGRASS WAY, SAND CITY, CA 93955
 PROJECT TITLE
 MULTITUDE TRAIL PROJECT
 SHEET DESCRIPTION
PLAN & PROFILE

DESIGNED BY: IB
 DATE: 5/15/25
 SCALE: AS NOTED
 PROJECT NO.
1240127001
 DRAWING NO.
C4.12
 SHEET 18 OF XX

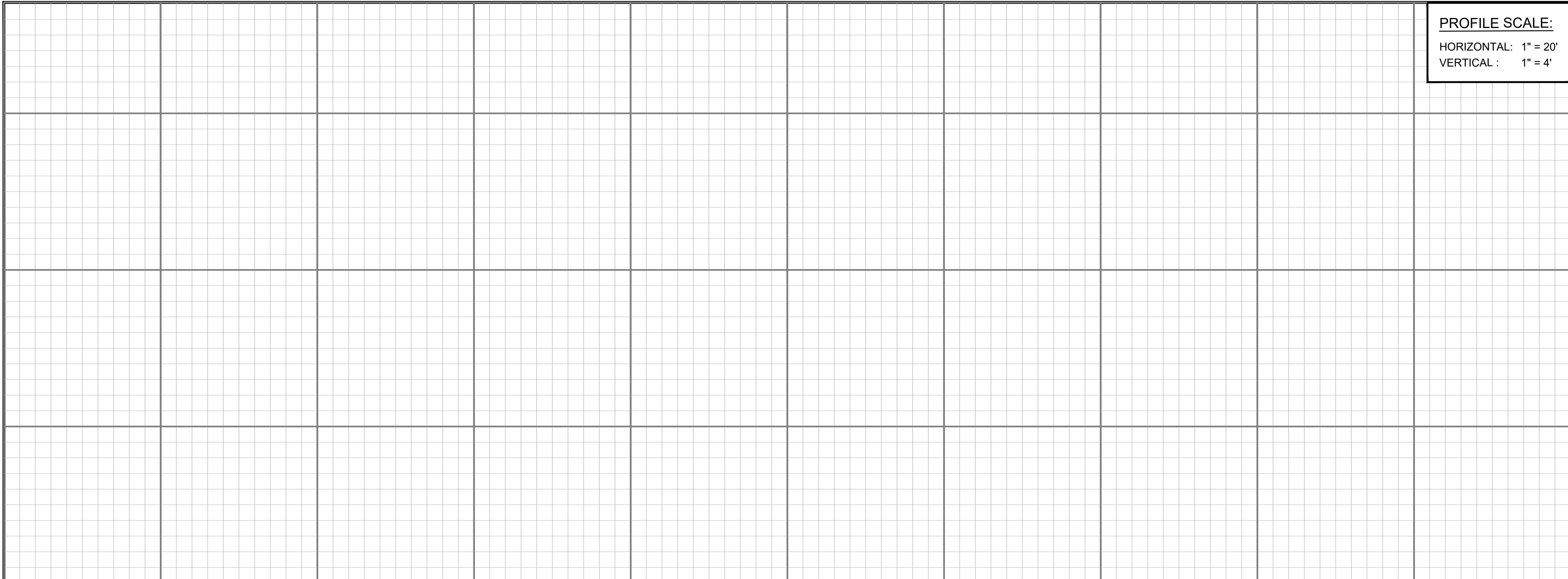

PROFILE

LEGEND

- PROPOSED ASPHALT CONCRETE PAVEMENT PER CN 1
- LANDSCAPE BUFFER (SEE LANDSCAPING PLANS SHEETS XX-XX)
- RIGHT OF WAY
- CITY LIMITS

CL CURVE AND LINE TABLE				
SEGMENT	LENGTH	BEARING	DELTA	RADIUS
C38	70.72'		6°39'11"	609.00'
C39	133.54'		13°18'22"	575.00'
C40	72.63'		6°50'00"	609.00'
C41	27.37'		44°48'15"	35.00'
C42	29.83'		44°58'55"	38.00'
C57	61.04'		4°58'03"	704.00'
C58	144.97'		14°07'33"	588.00'
C59	76.90'		7°07'06"	619.00'
C60	23.07'		41°18'50"	32.00'
L24	90.25'	N18°48'54"W		

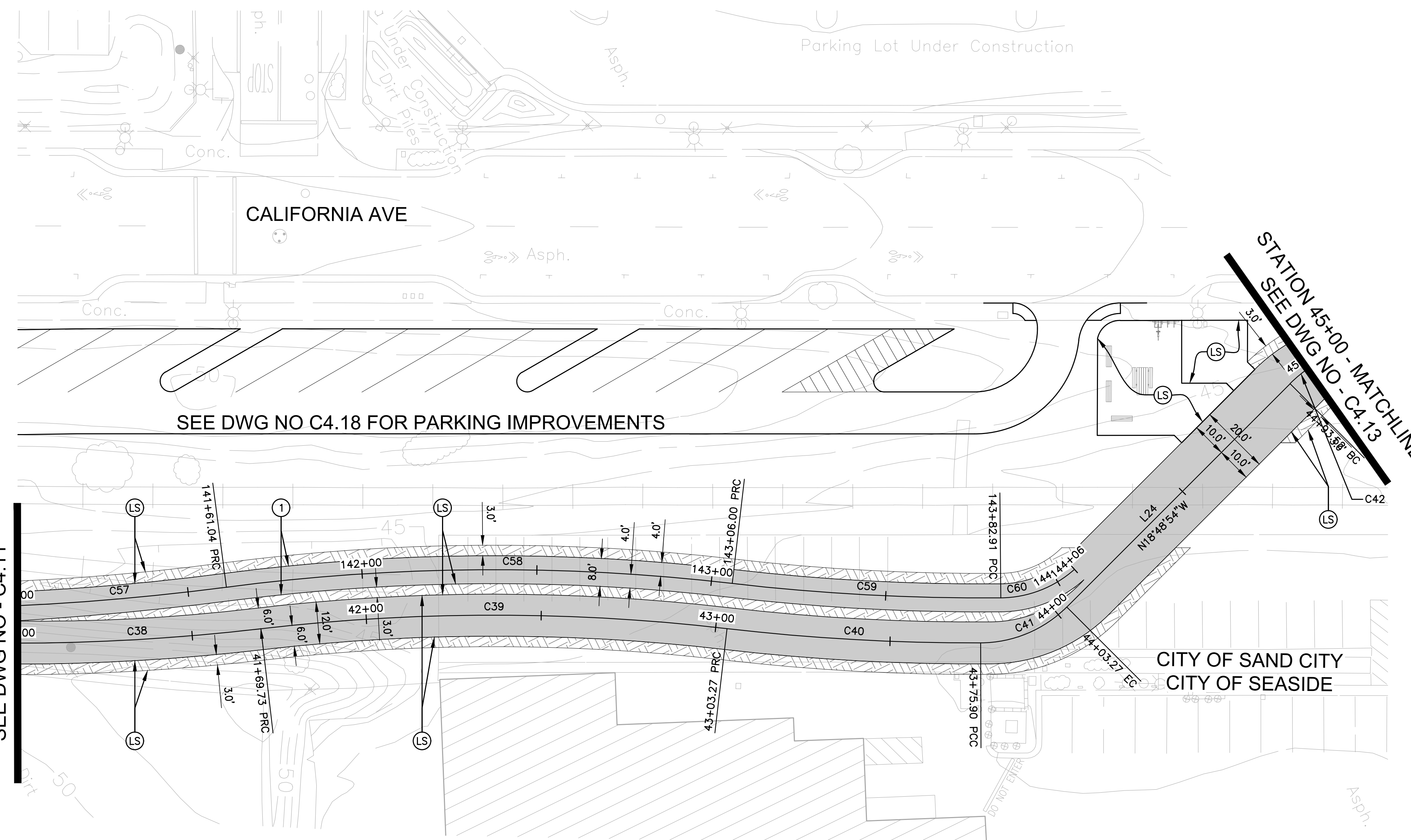

PLAN

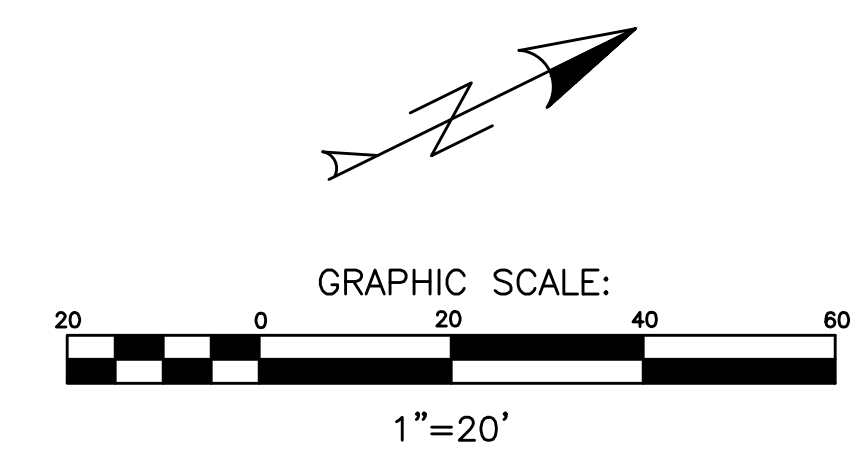

PROFILE SCALE:
 HORIZONTAL: 1" = 20'
 VERTICAL: 1" = 4'

CONSTRUCTION NOTES

- (P) PROTECT EXISTING IMPROVEMENT IN PLACE.
- (LS) SEE PROPOSED LANDSCAPING IMPROVEMENT PLAN SHEETS XX-XX.
- (SL) SEE PROPOSED LIGHTING IMPROVEMENT PLAN SHEETS XX-XX.
- (1) CONSTRUCT 4-INCH FULL DEPTH ASPHALT CONCRETE, GRADE PG XX-XX OVER COMPACTED NATIVE TO 95% RELATIVE COMPACTION. SCARIFY AND RECOMPACT SUB BASE (6-IN MINIMUM).



REVISIONS NO.	DATE	INITIAL	DESCRIPTION
△			NOT FOR CONSTRUCTION
△			DRAFT SUBMITTAL

Harris & Associates

60 W Alisal Street, Suite 200, Salinas, CA 93901
 p. 831.233.9242 * WeAreHarris.com

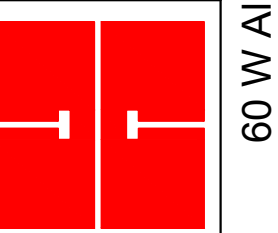

LEGEND

- PROPOSED ASPHALT CONCRETE PAVEMENT PER CN 1
- LANDSCAPE BUFFER (SEE LANDSCAPING PLANS SHEETS XX-XX)
- RIGHT OF WAY
- CITY LIMITS

CL CURVE AND LINE TABLE				
SEGMENT	LENGTH	BEARING	DELTA	RADIUS
C42	29.83'		44°58'55"	38.00'
C61	57.52'		15°02'57"	219.00'
C62	75.11'		19°49'58"	217.00'
C63	114.77'		11°26'12"	575.00'
C70	11.62'		3°15'47"	204.00'
C71	138.34'		13°28'47"	588.00'
L25	72.50'	N26°10'02"E		
L27	51.50'	N26°11'34"E		

PROFILE

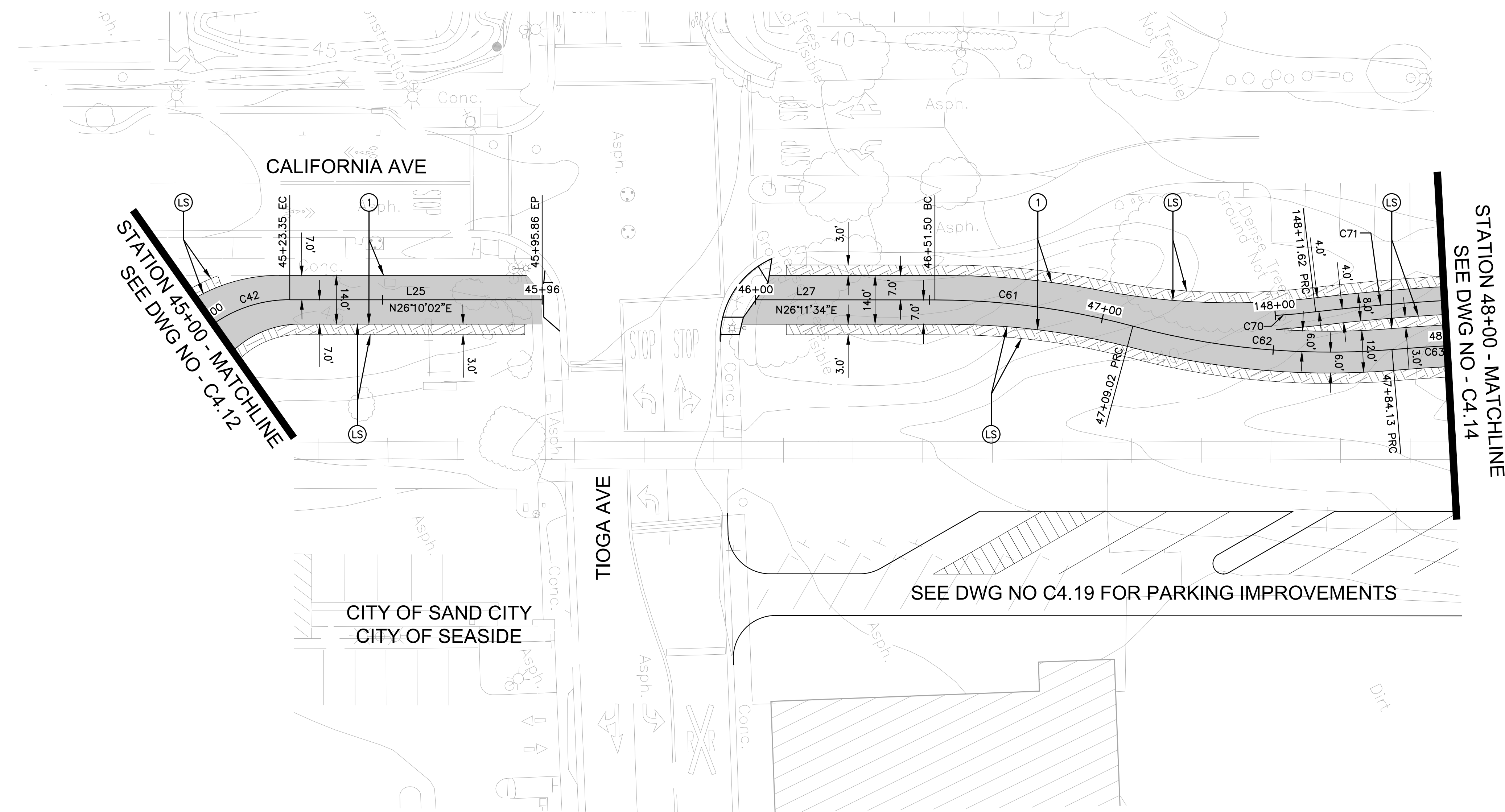
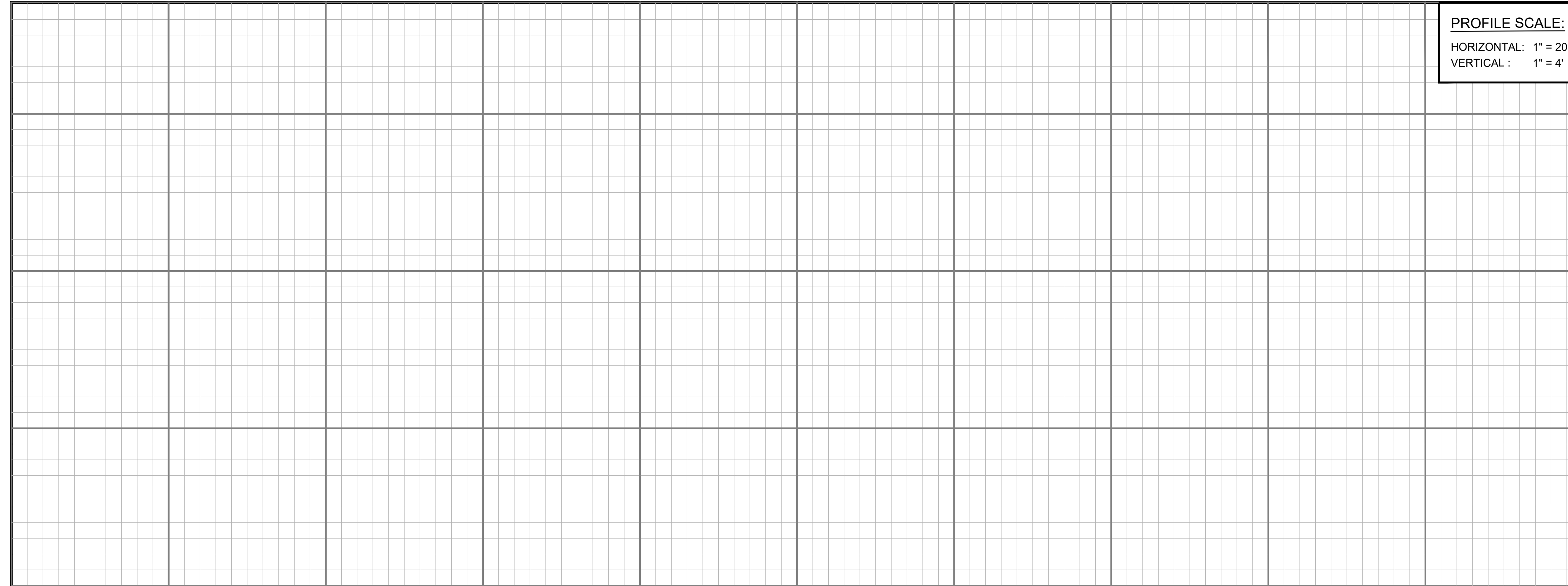

STATION 48+00 - MATCHLINE
 SEE DWG NO - C4.14

STATION 45+00 - MATCHLINE
 SEE DWG NO - C4.12

SEE DWG NO C4.19 FOR PARKING IMPROVEMENTS

PLAN

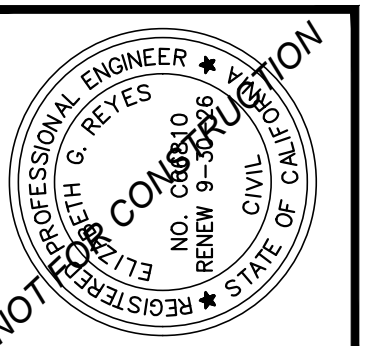
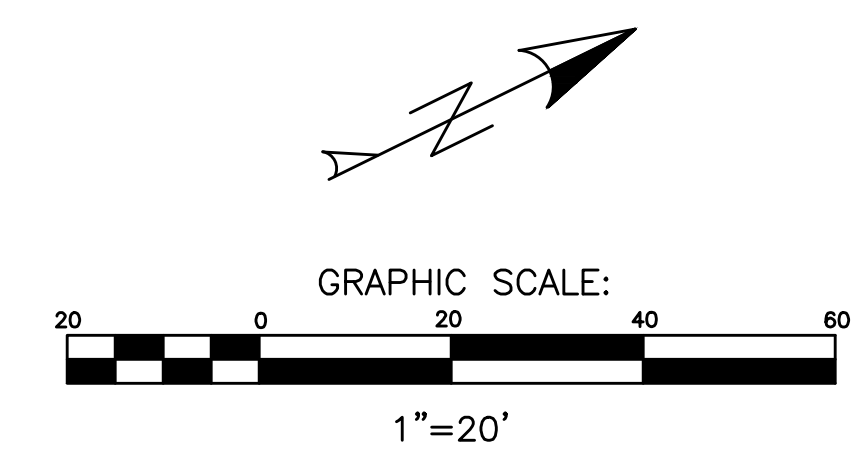

CITY OF SAND CITY
 1 PENDERGRASS WAY, SAND CITY, CA 93955
 PROJECT TITLE
 MULTIUSE TRAIL PROJECT
 SHEET DESCRIPTION
PLAN & PROFILE

DESIGNED BY: IB
 DATE: 5/15/25
 SCALE: AS NOTED
 PROJECT NO.
 1240127001
 DRAWING NO.
C4.13
 SHEET 19 OF XX



PROFILE SCALE:
 HORIZONTAL: 1" = 20'
 VERTICAL: 1" = 4'

CONSTRUCTION NOTES

- (P) PROTECT EXISTING IMPROVEMENT IN PLACE.
- (LS) SEE PROPOSED LANDSCAPING IMPROVEMENT PLAN SHEETS XX-XX.
- (SL) SEE PROPOSED LIGHTING IMPROVEMENT PLAN SHEETS XX-XX.
- (1) CONSTRUCT 4-INCH FULL DEPTH ASPHALT CONCRETE, GRADE PG XX-XX OVER COMPACTED NATIVE TO 95% RELATIVE COMPACTION. SCARIFY AND RECOMPACT SUB BASE (6-IN MINIMUM).

REVISIONS NO.	DATE	INITIAL	DESCRIPTION
△			NOT FOR CONSTRUCTION
△			DRAFT SUBMITTAL

Harris & Associates

60 W Alisal Street, Suite 200, Salinas, CA 93901
 p. 831.233.9242 * WeAreHarris.com

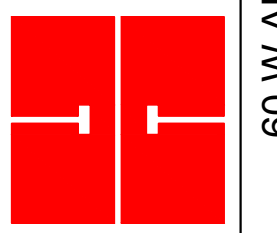

PROFILE

LEGEND

- PROPOSED ASPHALT CONCRETE PAVEMENT PER CN 1
- LANDSCAPE BUFFER (SEE LANDSCAPING PLANS SHEETS XX-XX)
- RIGHT OF WAY
- CITY LIMITS

CL CURVE AND LINE TABLE				
SEGMENT	LENGTH	BEARING	DELTA	RADIUS
C63	114.77'		11°26'12"	575.00'
C64	141.43'		13°18'23"	609.00'
C65	110.48'		11°00'30"	575.00'
C66	129.84'		12°12'56"	609.00'
C71	138.34'		13°28'47"	588.00'
C72	138.42'		13°18'23"	596.00'
C73	136.56'		13°18'23"	588.00'
C74	31.46'		3°01'26"	596.00'

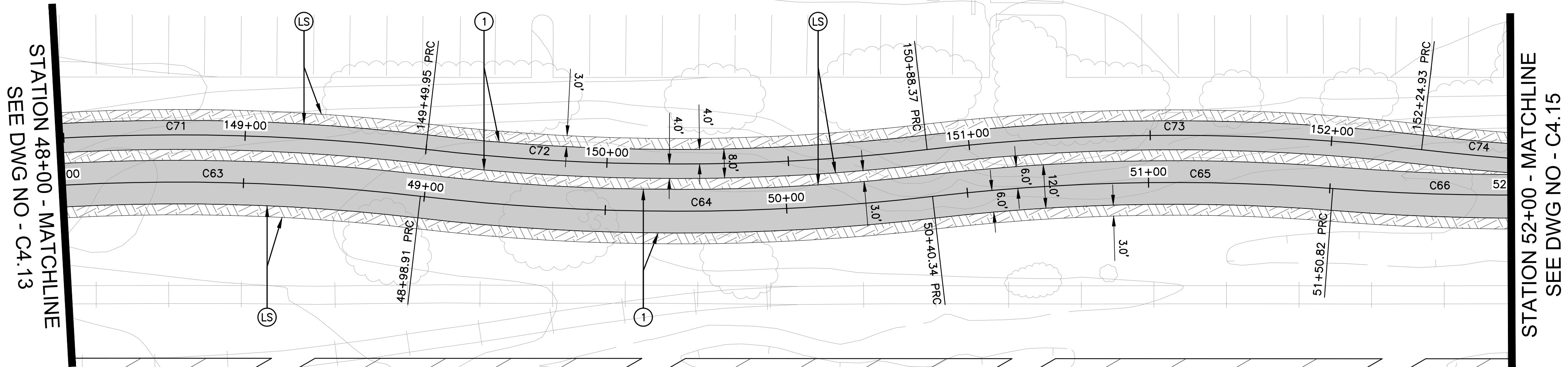

STATION 48+00 - MATCHLINE
SEE DWG NO - C4.13

STATION 52+00 - MATCHLINE
SEE DWG NO - C4.15

SEE DWG NO C4.19 FOR PARKING IMPROVEMENTS

CITY OF SAND CITY
CITY OF SEASIDE

PLAN

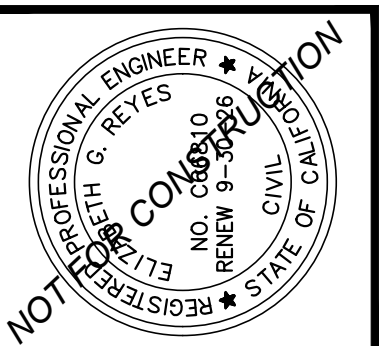
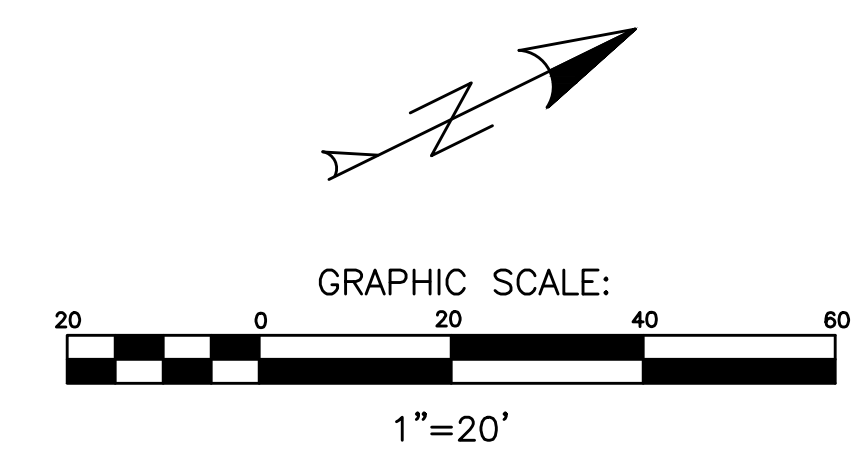

CITY OF SAND CITY
 1 PENDERGRASS WAY, SAND CITY, CA 93955
 PROJECT TITLE
 MULTITUDE TRAIL PROJECT
 SHEET DESCRIPTION
PLAN & PROFILE

DESIGNED BY: IB
 DATE: 5/15/25
 SCALE: AS NOTED
 PROJECT NO.
 1240127001
 DRAWING NO.
C4.14
 SHEET 20 OF XX



PROFILE SCALE:
 HORIZONTAL: 1" = 20'
 VERTICAL: 1" = 4'

CONSTRUCTION NOTES

- (P) PROTECT EXISTING IMPROVEMENT IN PLACE.
- (LS) SEE PROPOSED LANDSCAPING IMPROVEMENT PLAN SHEETS XX-XX.
- (SL) SEE PROPOSED LIGHTING IMPROVEMENT PLAN SHEETS XX-XX.
- (1) CONSTRUCT 4-INCH FULL DEPTH ASPHALT CONCRETE, GRADE PG XX-XX OVER COMPACTED NATIVE TO 95% RELATIVE COMPACTION. SCARIFY AND RECOMPACT SUB BASE (6-IN MINIMUM).

LEGEND

- PROPOSED ASPHALT CONCRETE PAVEMENT PER CN 1
- LANDSCAPE BUFFER (SEE LANDSCAPING PLANS SHEETS XX-XX)
- RIGHT OF WAY
- CITY LIMITS

CL CURVE AND LINE TABLE				
SEGMENT	LENGTH	BEARING	DELTA	RADIUS
C66	129.84'		12°12'56"	609.00'
C67	68.63'		7°51'51"	500.00'
C68	16.73'		19°33'29"	49.00'
C69	11.95'		19°33'29"	35.00'
C74	31.46'		3°01'26"	596.00'
L28	217.00'	N26°11'47"E		
L29	52.13'	N26°11'47"E		

PROFILE

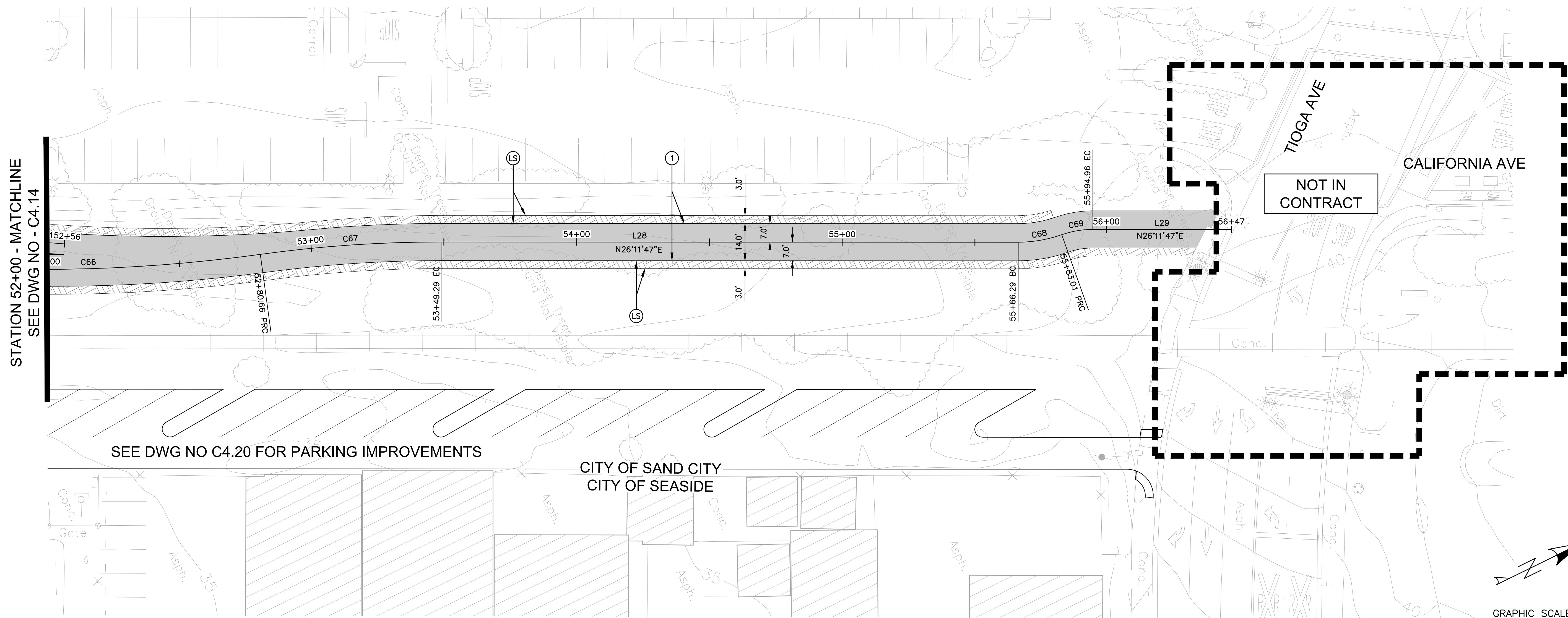

PLAN

STATION 52+00 - MATCHLINE
 SEE DWG NO - C4.14

SEE DWG NO C4.20 FOR PARKING IMPROVEMENTS

CITY OF SAND CITY
 CITY OF SEASIDE

REVISIONS	NO.	DATE	INITIAL	DESCRIPTION
	1			NOT FOR CONSTRUCTION
	2			DRAFT SUBMITTAL

Harris & Associates
 60 W Alisal Street, Suite 200, Salinas, CA 93901
 p. 831.233.9242 * WeAreHarris.com

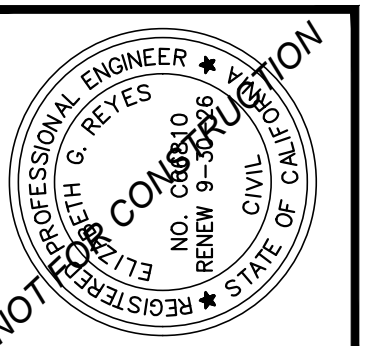

CITY OF SAND CITY
 1 PENDERGRASS WAY, SAND CITY, CA 93955
 PROJECT TITLE
 MULTITUDE TRAIL PROJECT
 SHEET DESCRIPTION
PLAN & PROFILE

DESIGNED BY: IB
 DATE: 5/15/25
 SCALE: AS NOTED
 PROJECT NO.
 1240127001
 DRAWING NO.
C4.15
 SHEET 21 OF XX

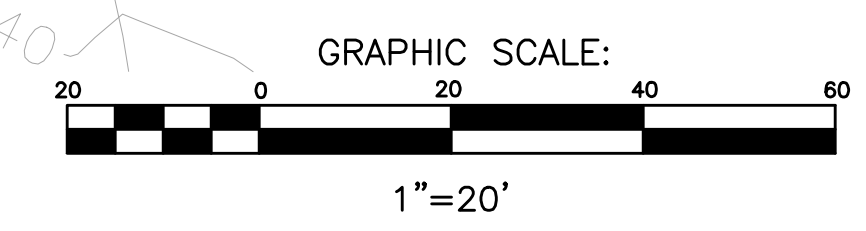



REVISIONS	NO.	DATE	INITIAL	DESCRIPTION
	1			NOT FOR CONSTRUCTION
	2			DRAFT SUBMITTAL

Harris & Associates

60 W Alisal Street, Suite 200, Salinas, CA 93901
 p. 831.233.9242 * WeAreHarris.com

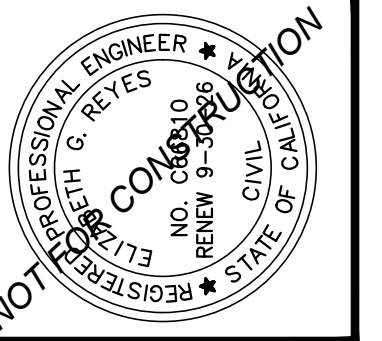

CITY OF SAND CITY
 1 PENDERGRASS WAY, SAND CITY, CA 93955
 PROJECT TITLE
 MULTIUSE TRAIL PROJECT
 SHEET DESCRIPTION
PARKING LOT IMPROVEMENTS

DESIGNED BY: IB
 DATE: 5/15/25
 SCALE: AS NOTED
 PROJECT NO.
1240127001
 DRAWING NO.
C4.16
 SHEET 22 OF XX

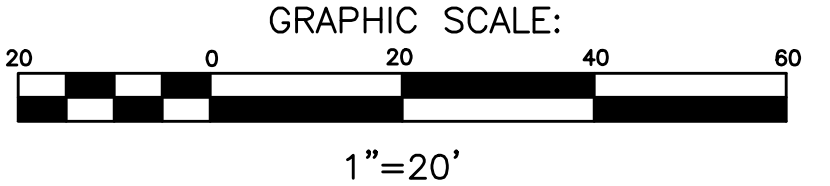
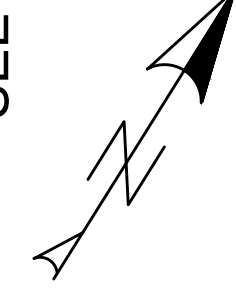
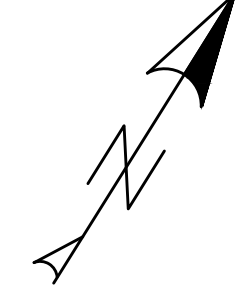
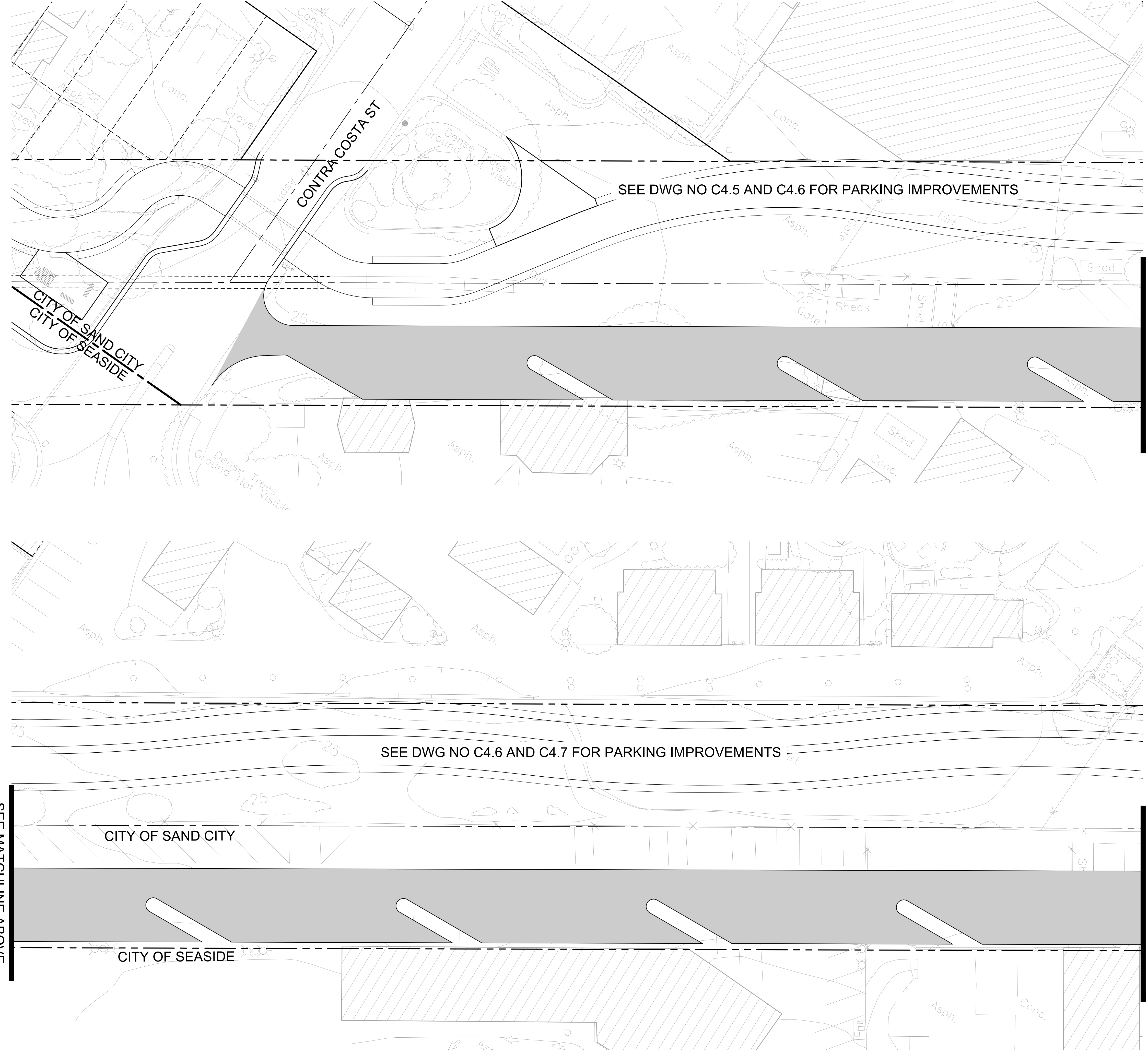



REVISIONS NO.	DATE	INITIAL	DESCRIPTION
△			NOT FOR CONSTRUCTION
△			DRAFT SUBMITTAL

Harris & Associates

60 W Alisal Street, Suite 200, Salinas, CA 93901
 p. 831.233.9242 * WeAreHarris.com

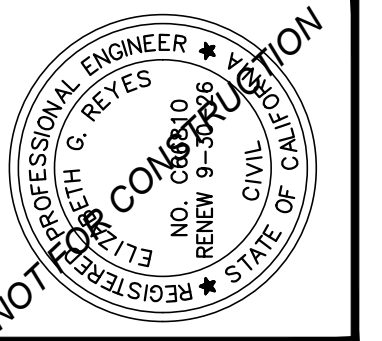

CITY OF SAND CITY
 1 PENDERGRASS WAY, SAND CITY, CA 93955
 PROJECT TITLE
 MULTIUSE TRAIL PROJECT
 SHEET DESCRIPTION
PARKING LOT IMPROVEMENTS

DESIGNED BY: IB
 DATE: 5/15/25
 SCALE: AS NOTED
 PROJECT NO.
 1240127001
 DRAWING NO.
C4.17
 SHEET 23 OF XX

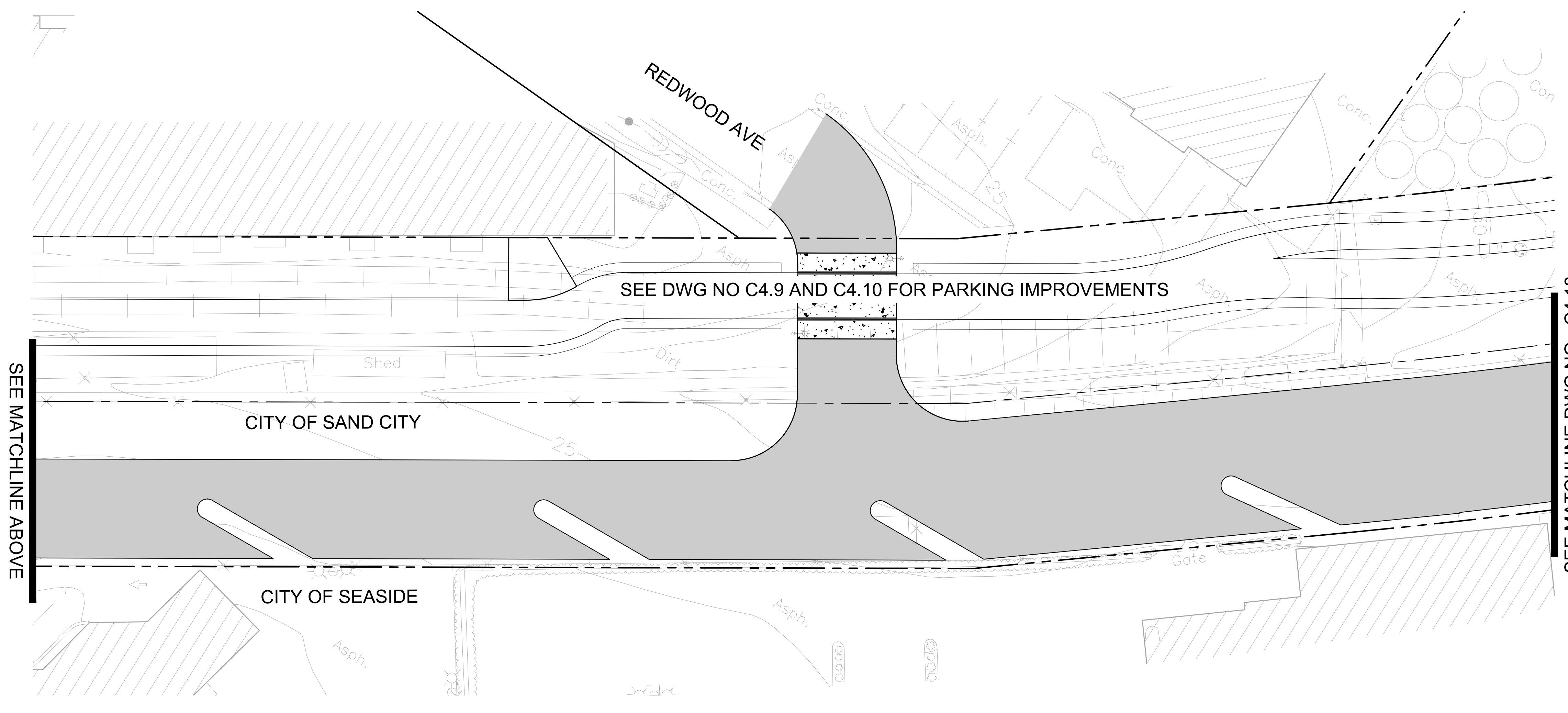
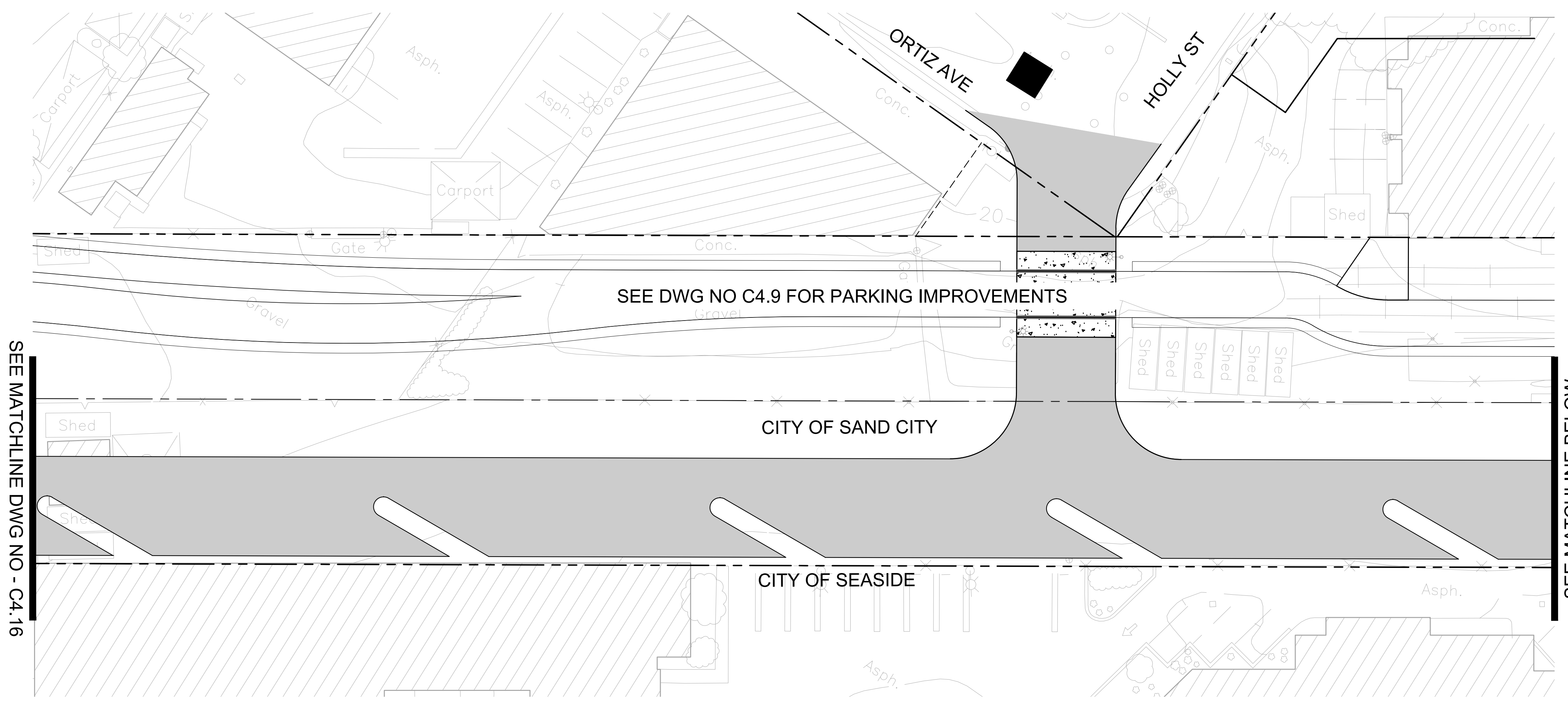

SEE MATCHLINE BELOW

SEE MATCHLINE DWG NO - C4.18

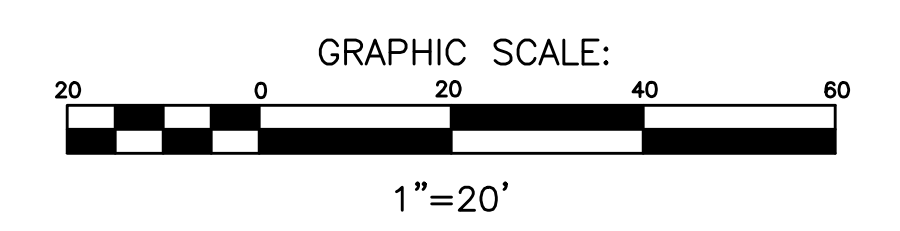
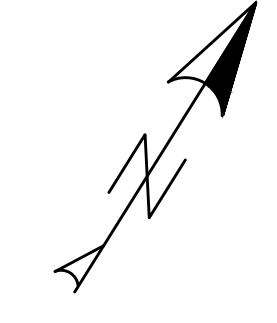
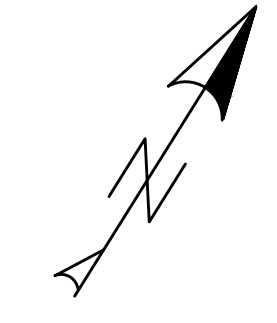



REVISIONS	NO.	DATE	INITIAL	DESCRIPTION
	1			NOT FOR CONSTRUCTION
	2			DRAFT SUBMITTAL

Harris & Associates

60 W Alisal Street, Suite 200, Salinas, CA 93901
p. 831.233.9242 * WeAreHarris.com

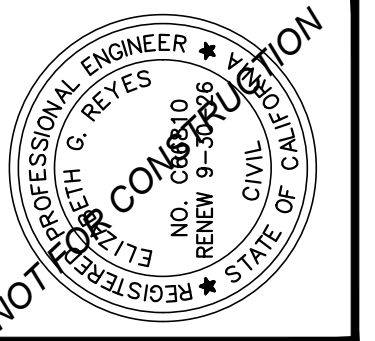
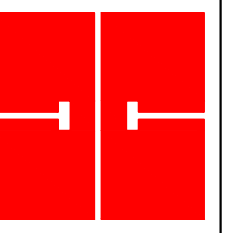

CITY OF SAND CITY
1 PENDERGRASS WAY, SAND CITY, CA 93955
PROJECT TITLE
MULTIUSE TRAIL PROJECT
SHEET DESCRIPTION
PARKING LOT IMPROVEMENTS

DESIGNED BY: IB
DATE: 5/15/25
SCALE: AS NOTED
PROJECT NO.
1240127001
DRAWING NO.
C4.18
SHEET 24 OF XX

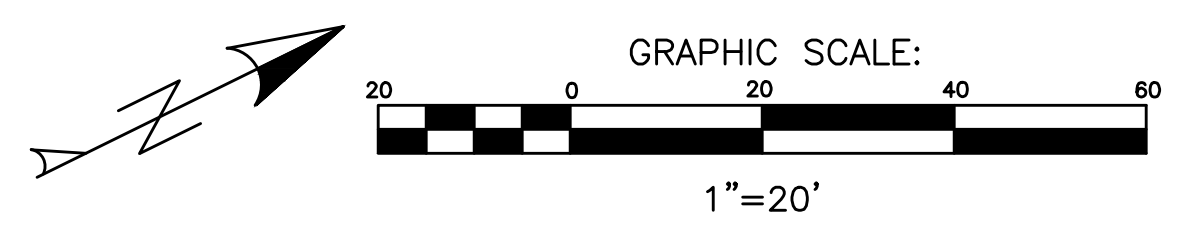
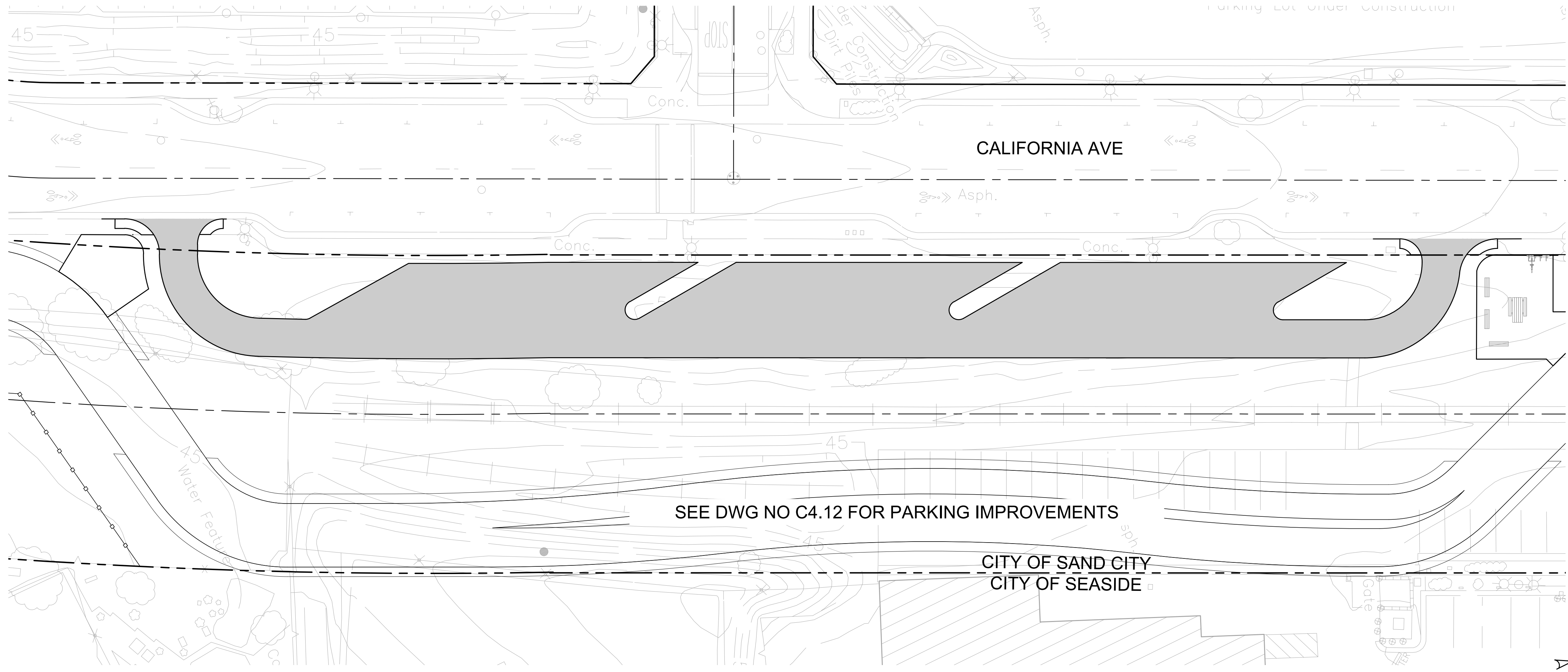
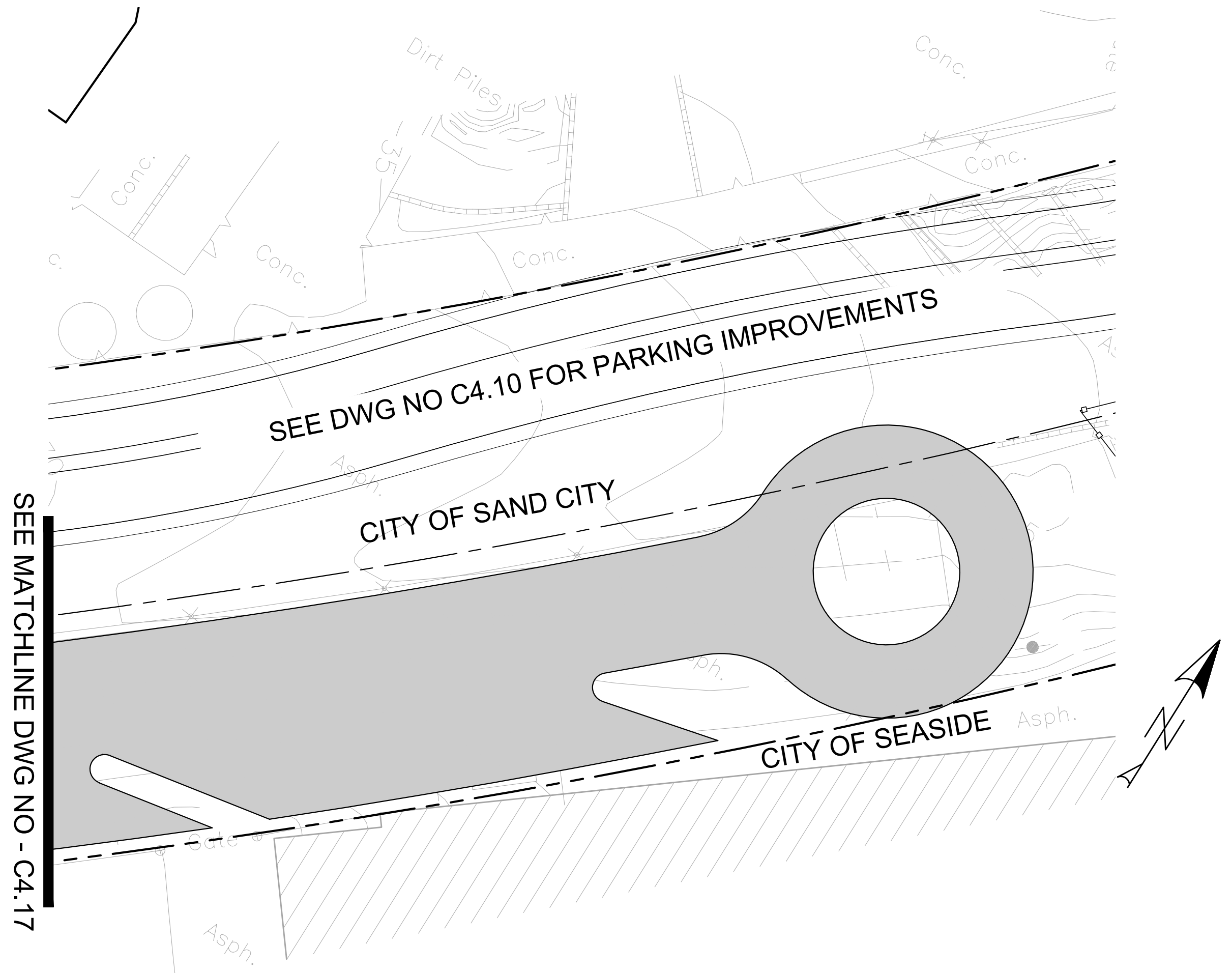



TIOGA AVE

CITY OF SAND CITY
CITY OF SEASIDE

SEE DWG NO C4.13 AND C4.14 FOR PARKING IMPROVEMENTS

SEE MATCHLINE BELOW

SEE DWG NO C4.15 FOR PARKING IMPROVEMENTS

CITY OF SAND CITY

CITY OF SEASIDE

SEE MATCHLINE DWG NO - C4.20

SEE MATCHLINE ABOVE



REVISIONS NO.	DATE	INITIAL	DESCRIPTION
△			NOT FOR CONSTRUCTION
△			DRAFT SUBMITTAL

Harris & Associates
 60 W Alisal Street, Suite 200, Salinas, CA 93901
 p. 831.233.9242 * WeAreHarris.com

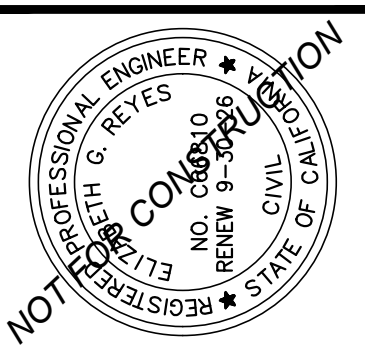

CITY OF SAND CITY
 1 PENDERGRASS WAY, SAND CITY, CA 93955
 PROJECT TITLE
 MULTITUDE TRAIL PROJECT
 SHEET DESCRIPTION
PARKING LOT IMPROVEMENTS

DESIGNED BY: IB
 DATE: 5/15/25
 SCALE: AS NOTED
 PROJECT NO.
 1240127001
 DRAWING NO.
C4.19
 SHEET 25 OF XX

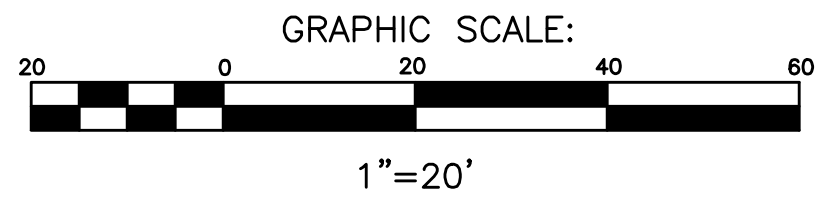
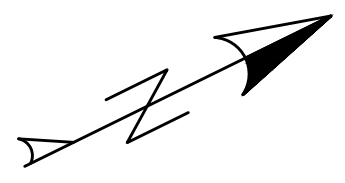
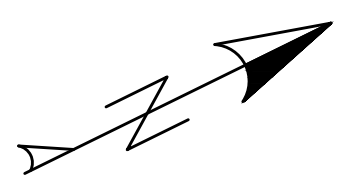

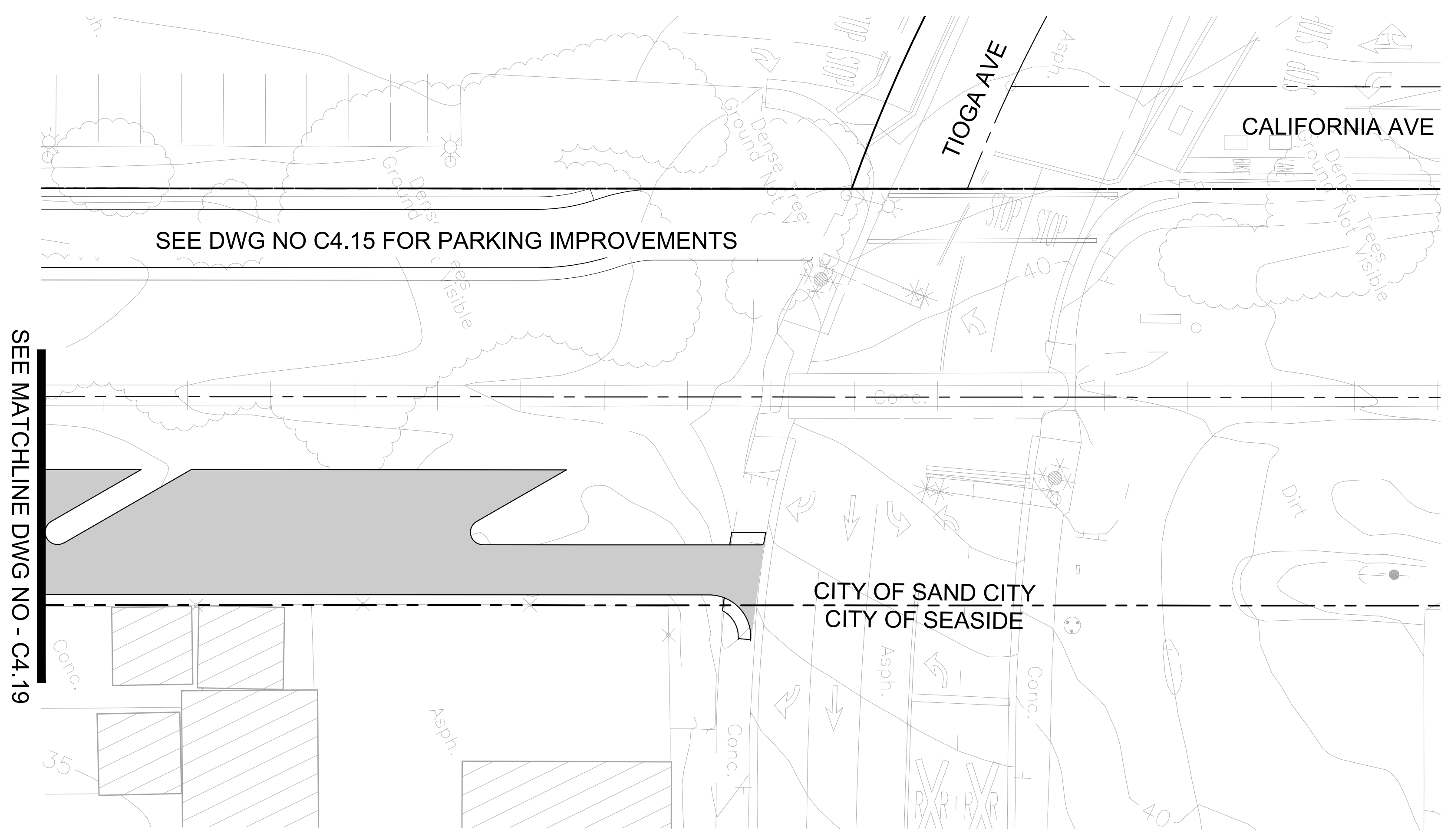

SEE MATCHLINE DWG NO - C4.19

SEE DWG NO C4.15 FOR PARKING IMPROVEMENTS

CITY OF SAND CITY
CITY OF SEASIDE

TIOGA AVE

CALIFORNIA AVE

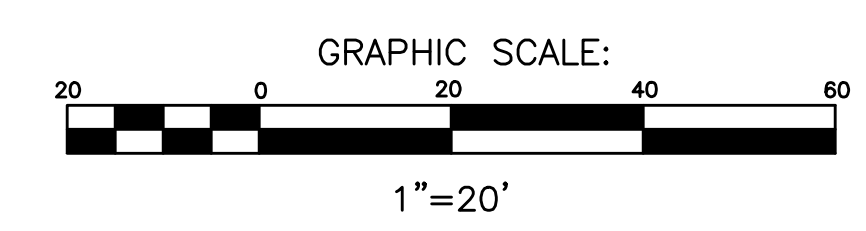
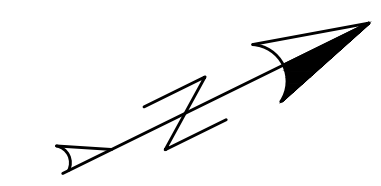

REVISIONS NO.	DATE	INITIAL	DESCRIPTION
△			NOT FOR CONSTRUCTION
△			DRAFT SUBMITTAL

Harris & Associates
 60 W Alisal Street, Suite 200, Salinas, CA 93901
 p. 831.233.9242 * WeAreHarris.com

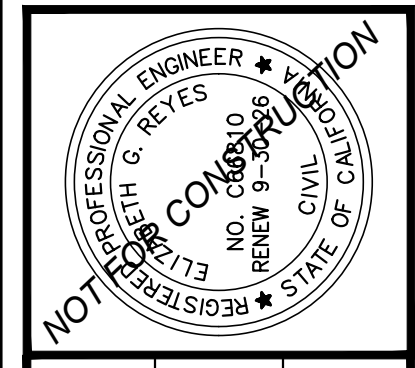

CITY OF SAND CITY
 1 PENDERGRASS WAY, SAND CITY, CA 93955
 PROJECT TITLE
 MULTIUSE TRAIL PROJECT
 SHEET DESCRIPTION
PARKING LOT IMPROVEMENTS

DESIGNED BY: IB
 DATE: 5/15/25
 SCALE: AS NOTED
 PROJECT NO.
 1240127001
 DRAWING NO.
C4.20
 SHEET 26 OF XX



REVISIONS	NO.	DATE	INITIAL	DESCRIPTION
△	△	△	△	NOT FOR CONSTRUCTION
△	△	△	△	DRAFT SUBMITTAL

Harris & Associates

60 W Alisal Street, Suite 200, Salinas, CA 93901
p. 831.233.9242 * WeAreHarris.com

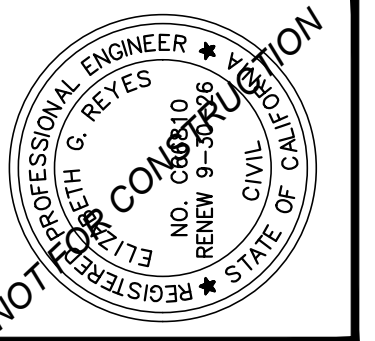

CITY OF SAND CITY
1 PENDERGRASS WAY, SAND CITY, CA 93955
PROJECT TITLE
MULTI-USE TRAIL PROJECT
SHEET DESCRIPTION
SIGNING AND STRIPING

DESIGNED BY: IB
DATE: 5/15/25
SCALE: AS NOTED
PROJECT NO.
1240127001
DRAWING NO.
C5.1
SHEET 27 OF XX

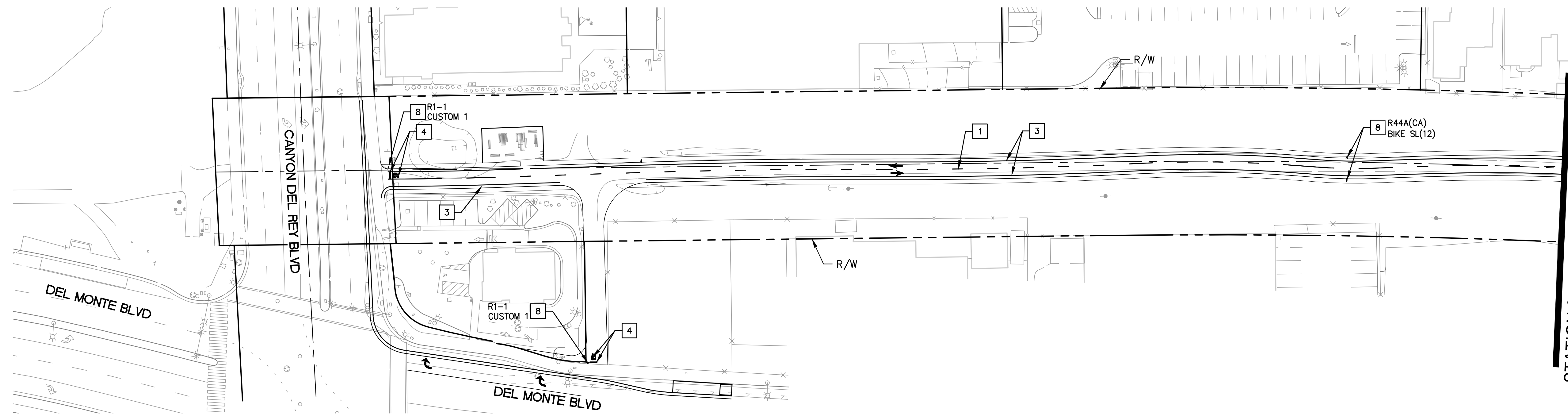

STATION 8+00 - SEE MATCHLINE BELOW

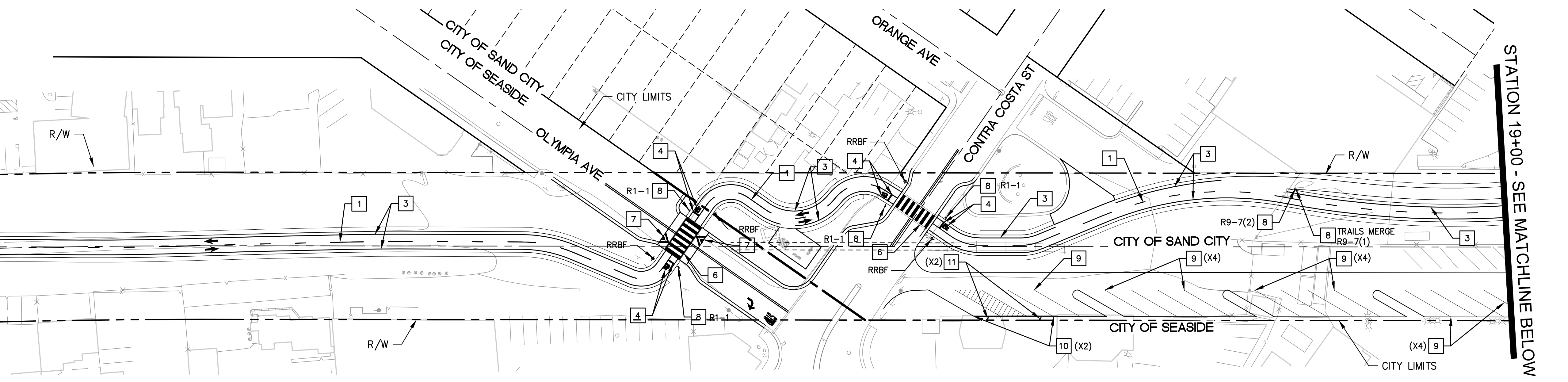

STATION 8+00 - SEE MATCHLINE ABOVE

STATION 19+00 - SEE MATCHLINE BELOW

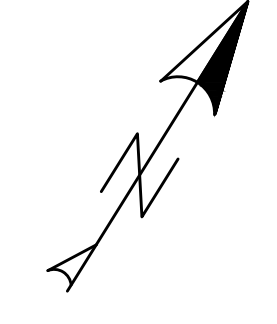
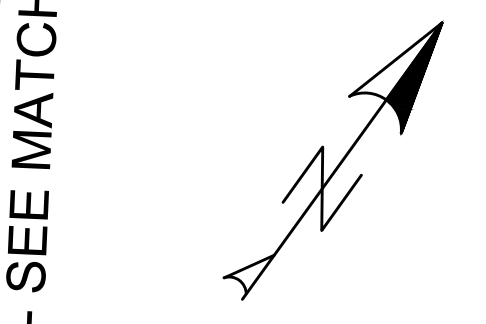

SIGN LEGEND

STRIPING CONSTRUCTION NOTES

- 1 PAINT 4-INCH WIDE, 3' LONG, WITH 9' GAP YELLOW SKIP CENTERLINE STRIPE ALONG CENTER OF THE BIKE TRAIL.
- 2 PAINT 6-INCH WIDE, SOLID DOUBLE YELLOW CENTERLINE STRIPE WITH RETROREFLECTIVE MARKERS PER CALTRANS STD DETAIL 22.
- 3 PAINT 4-INCH WIDE WHITE EDGELINE STRIPING PER CALTRANS STD DETAIL 27B.
- 4 INSTALL 12-INCH WIDE WHITE LIMIT LINE AND 'STOP' PAVEMENT LEGEND PER CALTRANS STD PLAN A24D.
- 5 PAINT WHITE YIELD LINE STRIPING AND 'YIELD' PAVEMENT LEGEND PER CALTRANS STD PLAN A24G.
- 6 INSTALL CONTINENTAL CROSSWALK PER CALTRANS STD PLAN A24F.
- 7 PAINT 12-INCH WIDE, WHITE SPEED TABLE MARKINGS PER SECTION 3B.29 AND FIGURE 3B-27 OF MUTCD 11TH EDITION GUIDELINES.
- 8 INSTALL SIGN AND POST AS INDICATED.
- 9 PAINT 3-INCH DOUBLE WHITE STRIPE PARKING STALL PER PARKING STALL DETAIL ON PLAN SHEET C5.3. STALL WIDTH AND DEPTH PER PLAN.
- 10 PAINT ACCESSIBLE PARKING STALL AND ACCESSIBLE AISLE STRIPING PER CALTRANS STD PLAN A90A.
- 11 INSTALL NEW R99C (CA) SIGN ON NEW POST PER CALTRANS STD PLAN A90A.

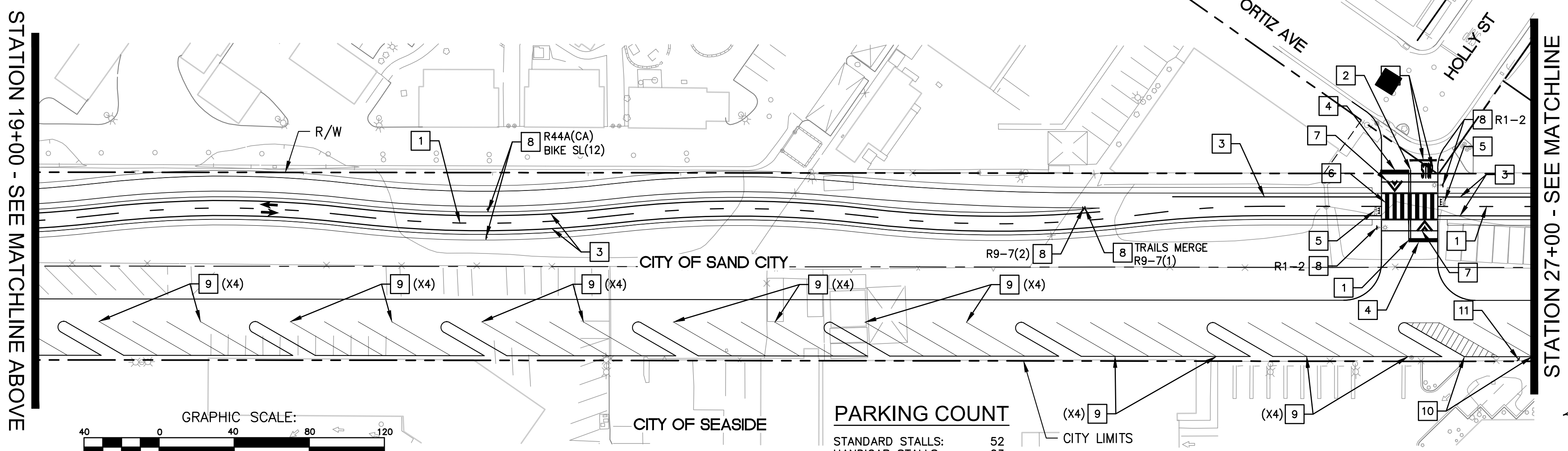

STATION 19+00 - SEE MATCHLINE ABOVE

STATION 27+00 - SEE MATCHLINE
DWG NO - C5.2

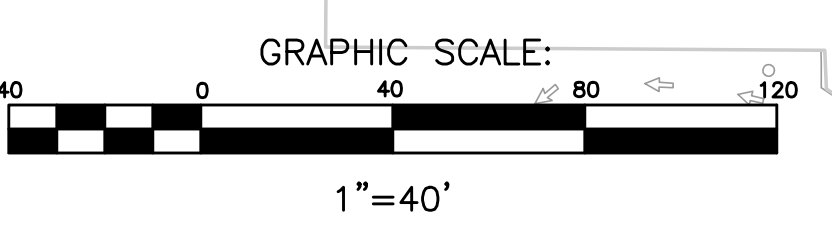

PARKING COUNT

STANDARD STALLS:	52
HANDICAP STALLS:	03
TOTAL STALLS:	55

(X4) 9 CITY LIMITS (X4) 9



STRIPING CONSTRUCTION NOTES

- 1 PAINT 4-INCH WIDE, 3' LONG, WITH 9' GAP YELLOW SKIP CENTERLINE STRIPE ALONG CENTER OF THE BIKE TRAIL.
- 2 PAINT 6-INCH WIDE, SOLID DOUBLE YELLOW CENTERLINE STRIPE WITH RETROREFLECTIVE MARKERS PER CALTRANS STD DETAIL 22.
- 3 PAINT 4-INCH WIDE WHITE EDGELINE STRIPING PER CALTRANS STD DETAIL 27B.
- 4 INSTALL 12-INCH WIDE WHITE LIMIT LINE AND 'STOP' PAVEMENT LEGEND PER CALTRANS STD PLAN A24D.
- 5 PAINT WHITE YIELD LINE STRIPING AND 'YIELD' PAVEMENT LEGEND PER CALTRANS STD PLAN A24G.
- 6 INSTALL CONTINENTAL CROSSWALK PER CALTRANS STD PLAN A24F.
- 7 PAINT 12-INCH WIDE, WHITE SPEED TABLE MARKINGS PER SECTION 3B.29 AND FIGURE 3B-27 OF MUTCD 11TH EDITION GUIDELINES.
- 8 INSTALL SIGN AND POST AS INDICATED.
- 9 PAINT 3-INCH DOUBLE WHITE STRIPE PARKING STALL PER PARKING STALL DETAIL ON PLAN SHEET C5.3. STALL WIDTH AND DEPTH PER PLAN.
- 10 PAINT ACCESSIBLE PARKING STALL AND ACCESSIBLE AISLE STRIPING PER CALTRANS STD PLAN A90A.
- 11 INSTALL NEW R99C (CA) SIGN ON NEW POST PER CALTRANS STD PLAN A90A.

SIGN LEGEND

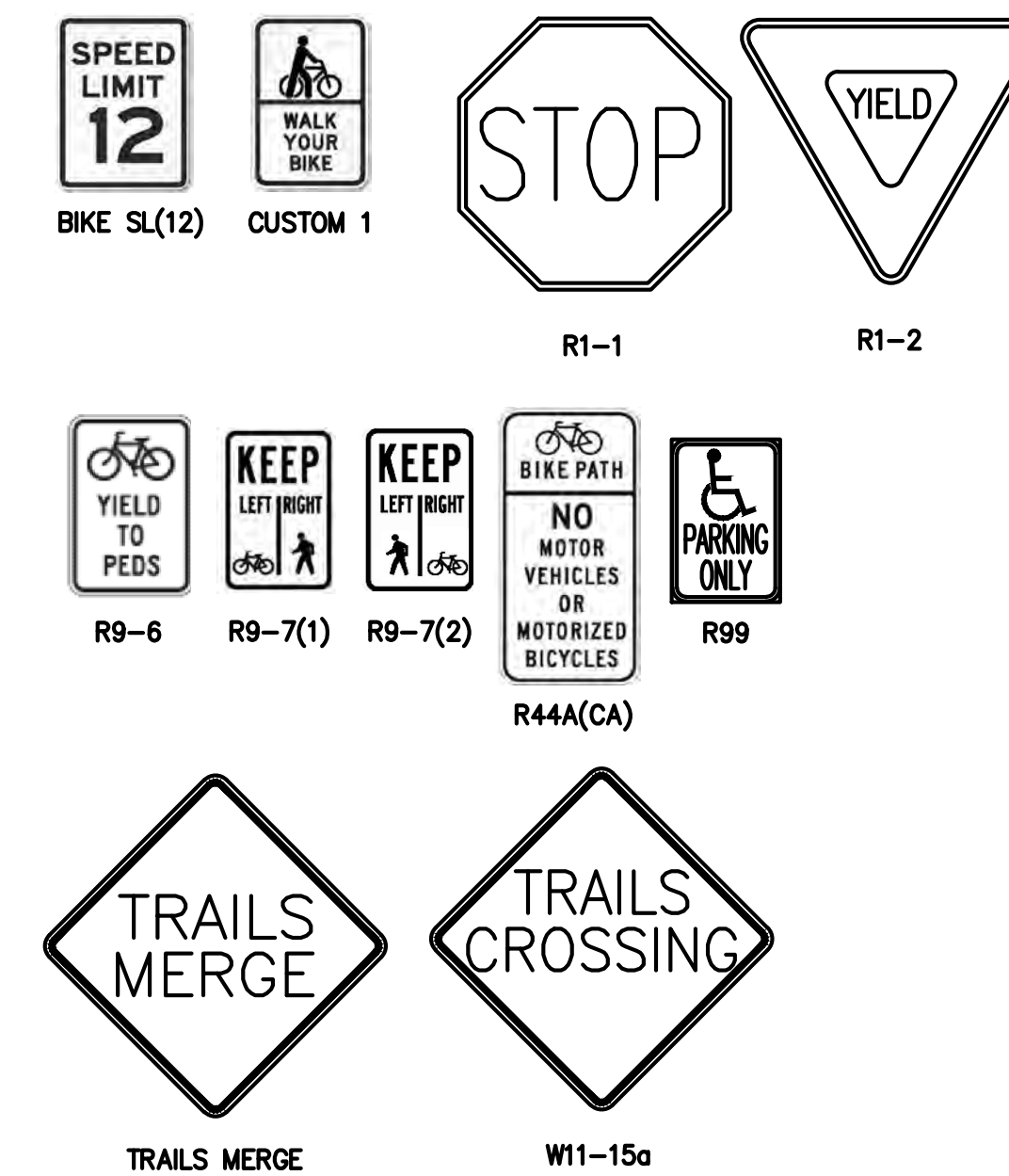

PARKING COUNT

STANDARD STALLS:	63
HANDICAP STALLS:	04
TOTAL STALLS:	67

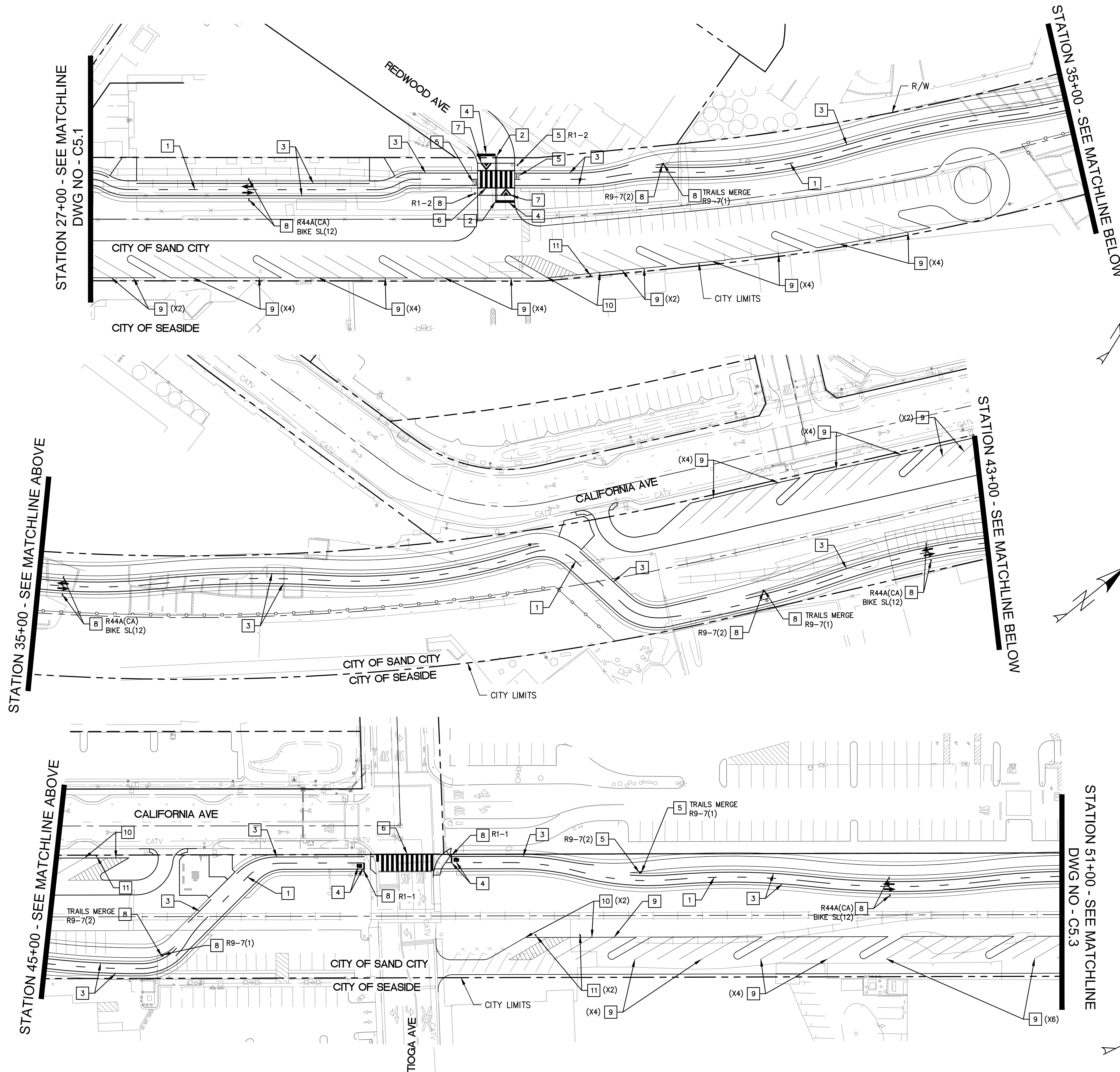
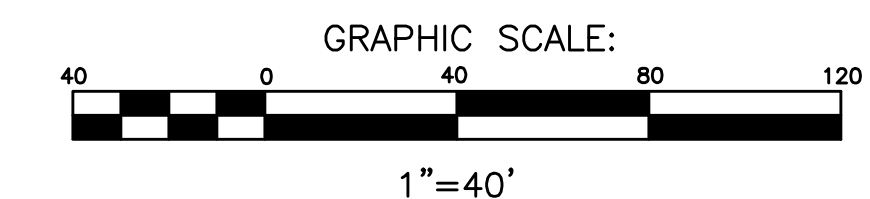

<p>REVISIONS</p> <table border="1" style="width: 100%; border-collapse: collapse;"> <thead> <tr> <th>NO.</th> <th>DATE</th> <th>INITIAL</th> <th>DESCRIPTION</th> </tr> </thead> <tbody> <tr> <td> </td> <td> </td> <td> </td> <td> </td> </tr> <tr> <td> </td> <td> </td> <td> </td> <td> </td> </tr> </tbody> </table> <p style="text-align: center; font-weight: bold; font-size: 1.2em;">NOT FOR CONSTRUCTION</p> <p style="text-align: center; font-weight: bold; font-size: 1.2em;">DRAFT SUBMITTAL</p>	NO.	DATE	INITIAL	DESCRIPTION									<p style="font-weight: bold; font-size: 1.2em;">Harris & Associates</p> <p>60 W Alisal Street, Suite 200, Salinas, CA 93901 p. 831.233.9242 * WeAreHarris.com</p> <div style="text-align: center;"> </div> <p style="font-weight: bold; font-size: 1.2em;">CITY OF SAND CITY</p> <p>1 PENDERGRASS WAY, SAND CITY, CA 93955 PROJECT TITLE MULTIUSE TRAIL PROJECT</p> <p style="font-weight: bold; font-size: 1.2em;">SIGNING & STRIPING</p> <p>DESIGNED BY: IB DATE: 5/15/25 SCALE: AS NOTED PROJECT NO. 1240127001 DRAWING NO. C5.2 SHEET 28 OF XX</p>
NO.	DATE	INITIAL	DESCRIPTION										



STATION 51+00 - SEE MATCHLINE
DWG NO - C5.2

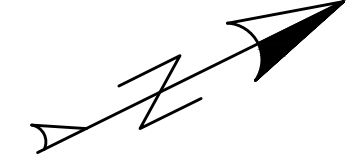
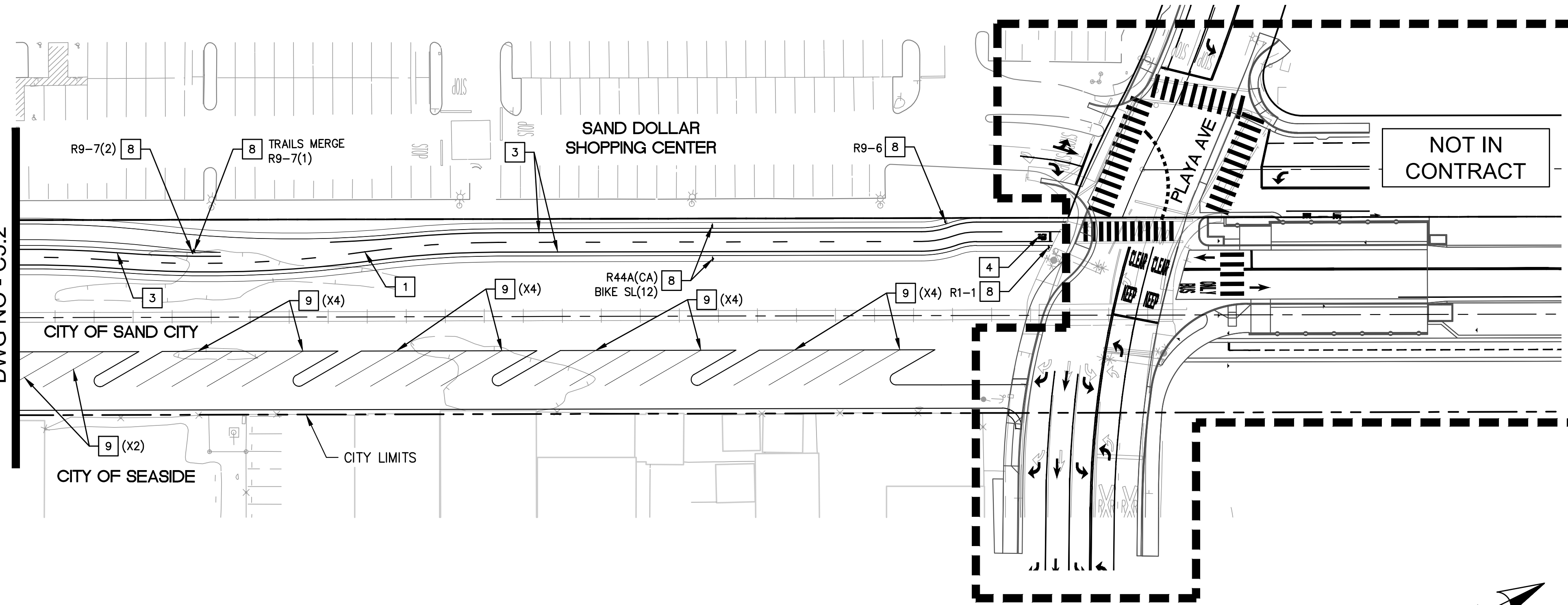

STRIPING CONSTRUCTION NOTES

- 1 PAINT 4-INCH WIDE, 3' LONG, WITH 9' GAP YELLOW SKIP CENTERLINE STRIPE ALONG CENTER OF THE BIKE TRAIL.
- 2 PAINT 4-INCH WIDE WHITE EDGELINE STRIPING PER CALTRANS STD DETAIL 27B.
- 6 PAINT 3-INCH DOUBLE WHITE STRIPE PARKING STALL PER PARKING STALL DETAIL ON PLAN SHEET C5.3. STALL WIDTH AND DEPTH PER PLAN.
- 7 PAINT ACCESSIBLE PARKING STALL AND ACCESSIBLE AISLE STRIPING PER CALTRANS STD PLAN A90A.
- 8 INSTALL NEW R99C (CA) SIGN ON NEW POST PER CALTRANS STD PLAN A90A.

PARKING COUNT

STANDARD STALLS:	23
HANDICAP STALLS:	00
TOTAL STALLS:	23

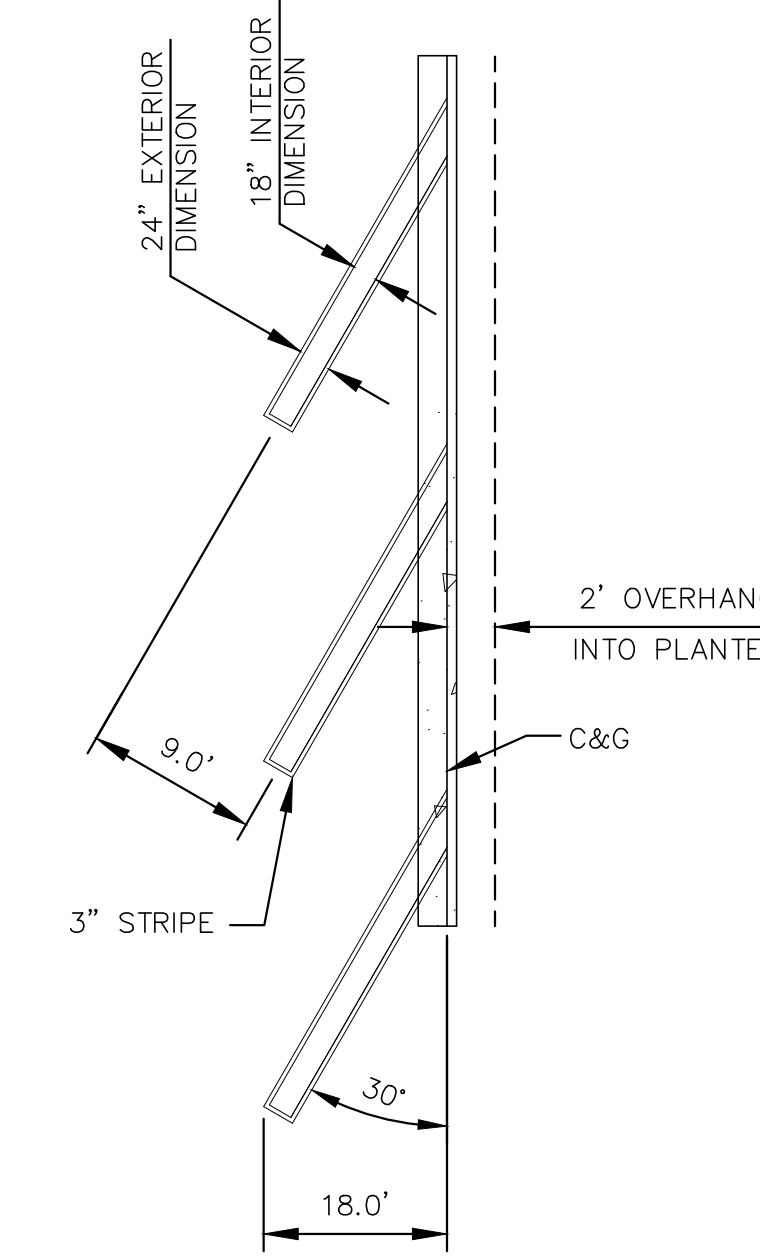

PARKING STALL DETAIL

REVISIONS	NO.	DATE	INITIAL	DESCRIPTION
	1			NOT FOR CONSTRUCTION
	2			DRAFT SUBMITTAL

Harris & Associates
 60 W Alisal Street, Suite 200, Salinas, CA 93901
 p. 831.233.9242 * WeAreHarris.com

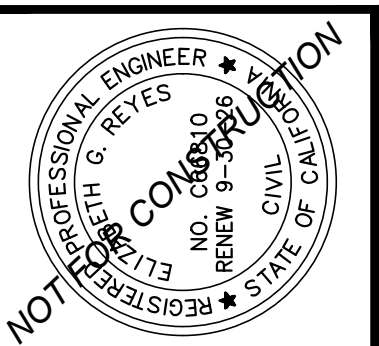

CITY OF SAND CITY
 1 PENDERGRASS WAY, SAND CITY, CA 93955
 PROJECT TITLE
 MULTIUSE TRAIL PROJECT
 SHEET DESCRIPTION
SIGNING & STRIPING

DESIGNED BY: IB
 DATE: 5/15/25
 SCALE: AS NOTED
 PROJECT NO.
 1240127001
 DRAWING NO.
 C5.3
 SHEET 29 OF XX

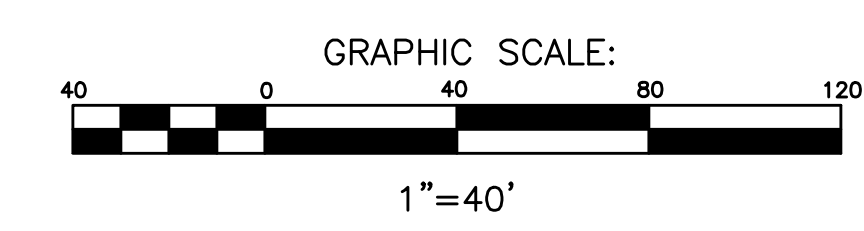

ATTACHMENT F

Update to 30% Plans



REVISIONS	NO.	DATE	INITIAL	DESCRIPTION
	1			NOT FOR CONSTRUCTION
	2			30% DRAFT SUBMITTAL

Harris & Associates
 60 W Alisal Street, Suite 200, Salinas, CA 93901
 p. 831.233.9242 WeAreHarris.com

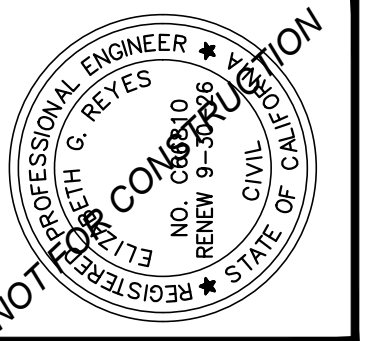

CITY OF SAND CITY
 1 PENDERGRASS WAY, SAND CITY, CA 93955
 PROJECT TITLE: MULTITUDE TRAIL PROJECT
 SHEET DESCRIPTION: EXHIBIT - PARKING LOT LAYOUT
 DESIGNED BY: IB
 DATE: 4/1/26
 SCALE: AS NOTED
 PROJECT NO.: 1240127001
 DRAWING NO.: --
 SHEET -- OF 52

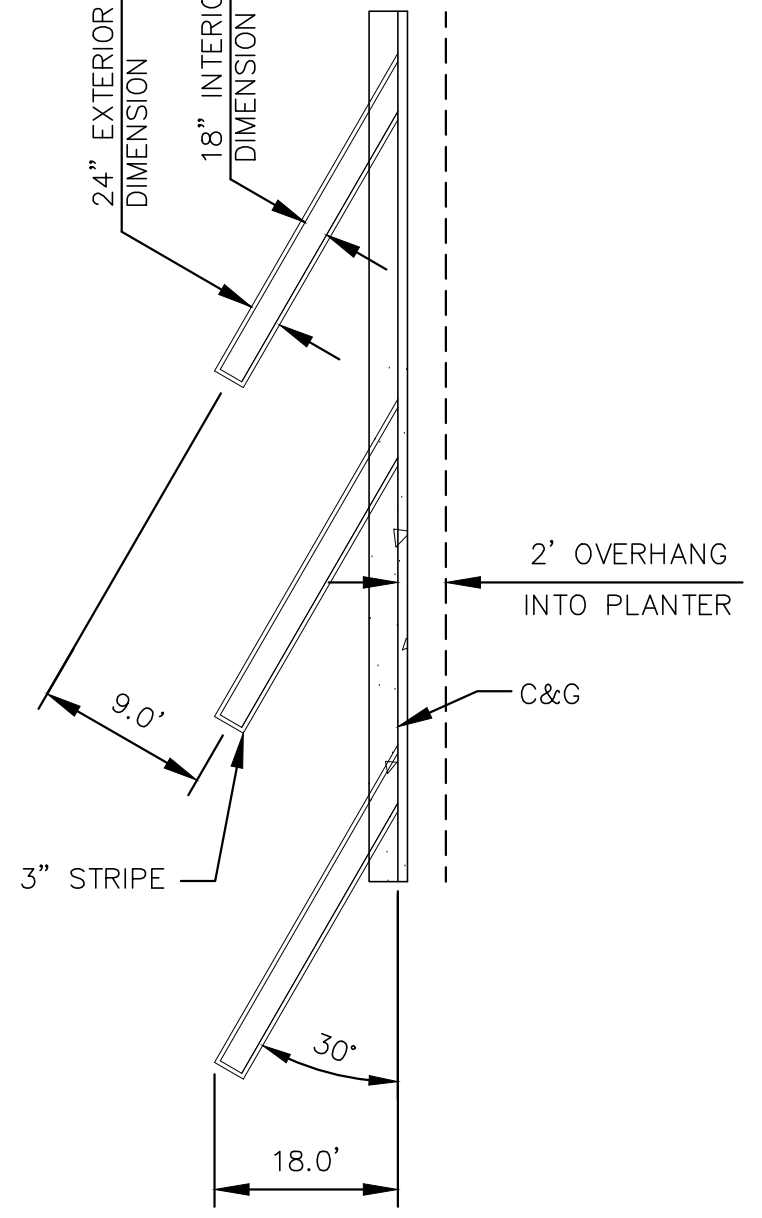
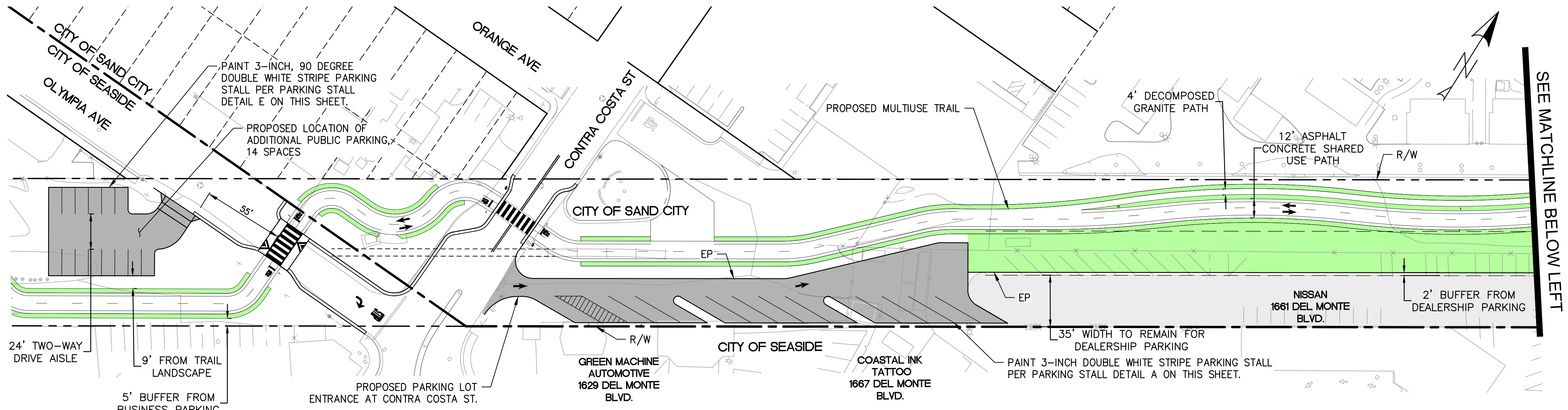

DETAIL A

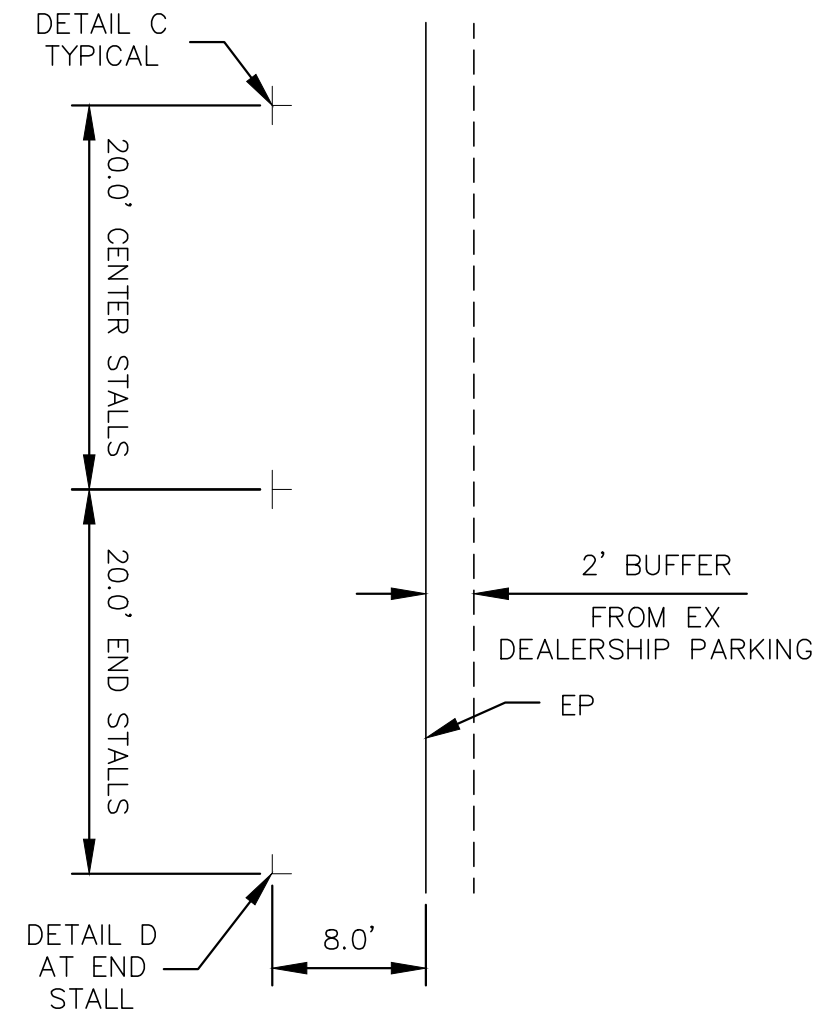
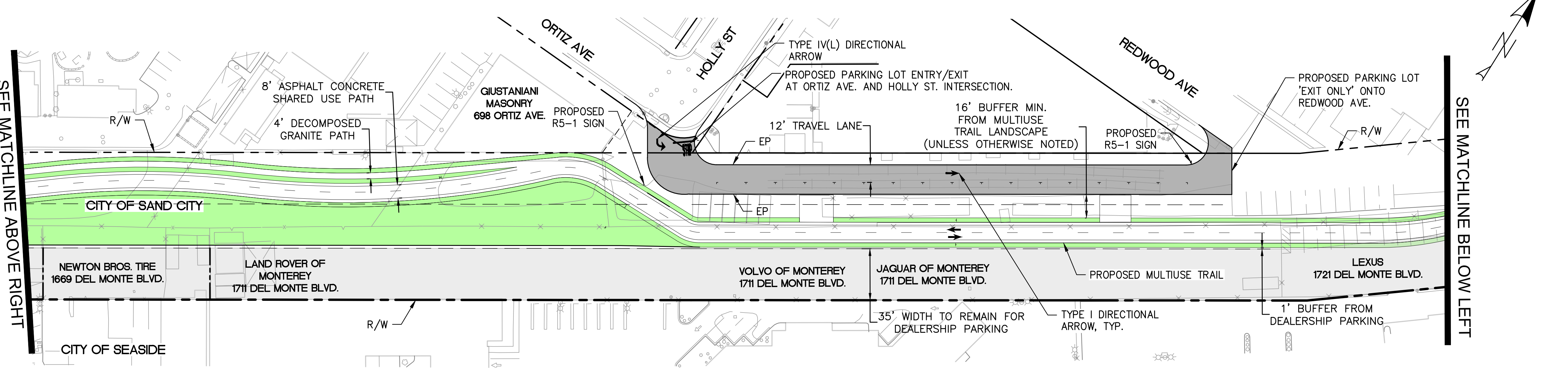

DETAIL B

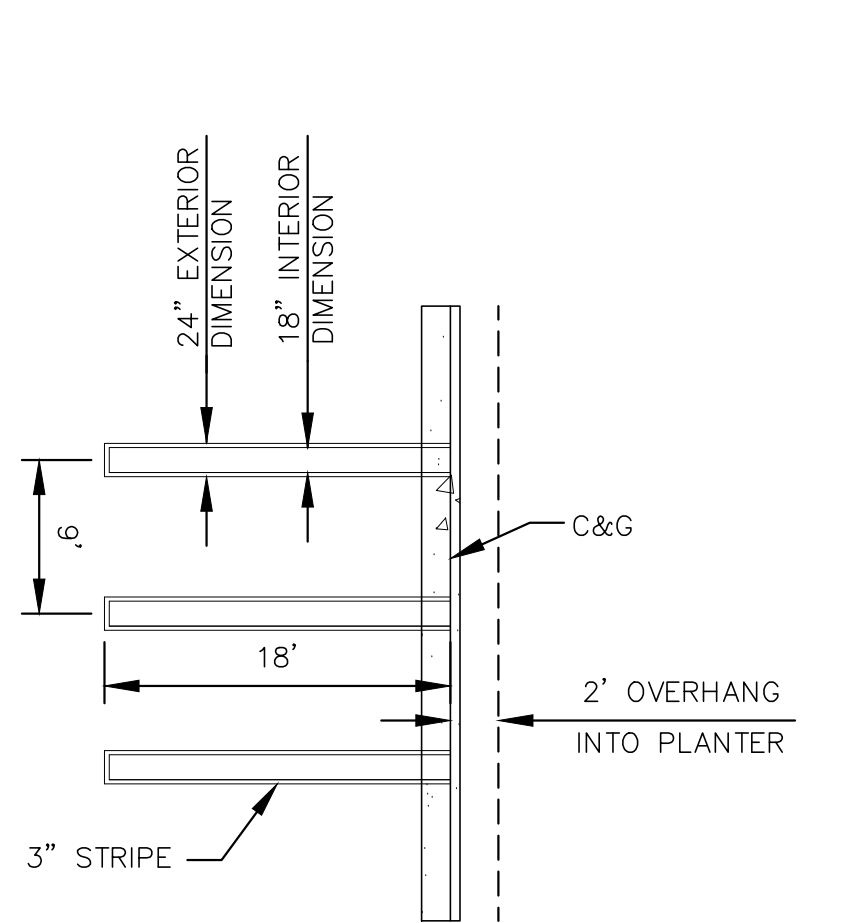
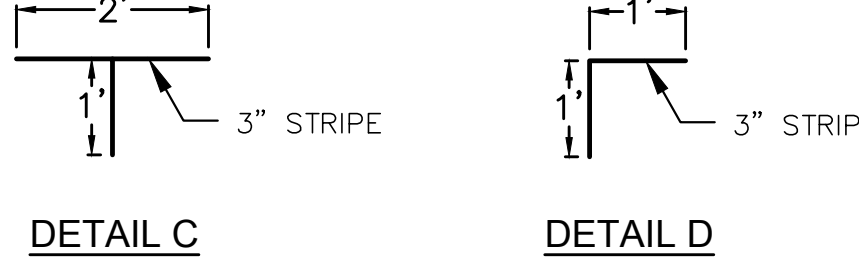
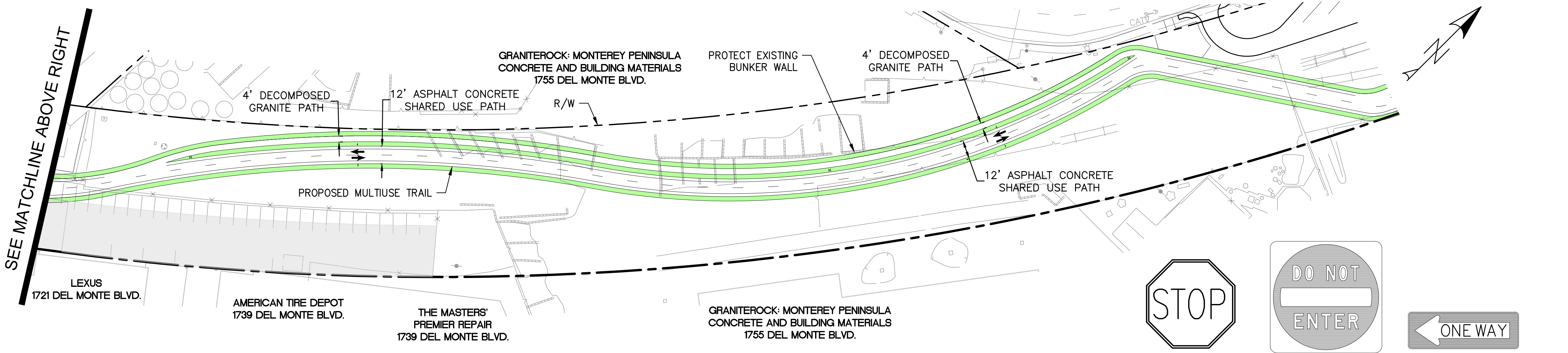

DETAIL E

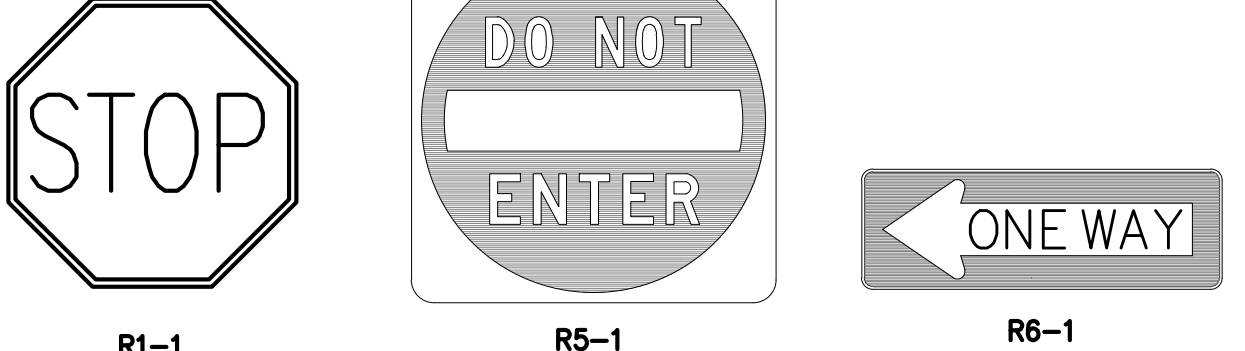
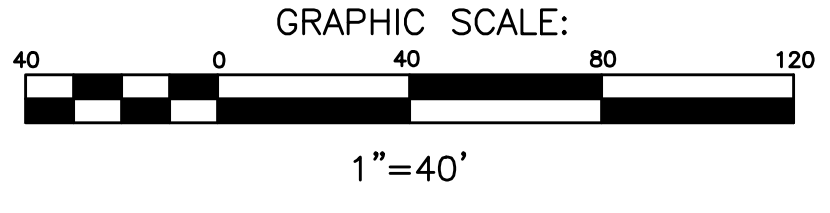

SIGN LEGEND

EXHIBIT A: Scope of Work and Schedule

Project Title:

Consultant Project Manager:

Scope of Work

(by task, including Deliverables)

Project Schedule

EXHIBIT B: Budget and Sample Cost Proposal

EXHIBIT C: ADA Best Practices for Documents and Outreach

The following are best practices that Sand City commits to complying with, and asks that all final and public draft documents comply, as they align with best practices for web-content accessibility:

Public Outreach Guidance

- Offer alternative ways to engage in outreach for the hard-of-hearing and the blind
 - Example: Have Talk-to-Text capacity available to engage with the hard of hearing
- Ensure public meeting rooms are set up in a way that is wheelchair accessible
- Ensure an alternative to a podium or stage is available in the event an individual cannot participate that way
- Have at least one wireless microphone available to help ensure public comments are projected in the meeting
- Develop public workshop handouts in font size 14 (minimum)
 - Handouts could include a project summary sheet, survey, comment card, etc.

Developing ADA Accessible Documents

- Use Calibri, Helvetica, or Arial Font Type
- Ensure final document content is at least font size 12 (minimum)
- Utilize proper features in Microsoft Word, including, but not limited to:
 - Alt Text for Images and Tables
 - “Styles” Feature to add emphasis or titles
 - Built in “Spacing” feature
- Indicate at the bottom of a Final Document’s Title Page, an ADA Notice stating:
 - **ADA Notice:** For individuals with sensory disabilities, this document is available in alternate formats. For information call (831) 775-0903 or Email cityhall@sandcityca.org.

Web Content Accessibility Guidelines

The Web Content Accessibility Guidance (WCAG) was integrated into Section 508 of the American with Disabilities Act in January 2018 as the industry standard in accessibility.

Guidance and Success Criteria from the WCAG are organized into the following four principles:

1. Perceivable
 - Provide text alternatives for non-text content.
 - Provide captions and other alternatives for multimedia.

- Create content that can be presented in different ways, including by assistive technologies, without losing meaning.
 - Make it easier for users to see and hear content.
2. Operable
 - Make all functionality available from a keyboard.
 - Give users enough time to read and use content.
 - Do not use content that causes seizures.
 - Help users navigate and find content.
 3. Understandable
 - Make text readable and understandable.
 - Make content appear and operate in predictable ways
 - Help users avoid and correct mistakes.
 4. Robust
 - Maximize compatibility with current and future user tools

A few key aspects that relate to content to be posted onto the Sand City website include:

- Integrating alternative text for images and maps
- Using distinguishable colors and design techniques that are comprehensible for the color-blind

For a complete list of WCAG's Guidance, see: <https://www.w3.org/TR/WCAG20/>

If Consultant or subconsultant needs clarification on ADA best practices, please contact cityhall@sandcityca.org.

EXHIBIT D: Title VI Exhibit for Federal Contracts

(US DOT Order 1050.2A)

During the performance of this contract, the contractor, for itself, its assignees, and successors in interest (hereinafter referred to as the “contractor”) agrees to comply with the following nondiscrimination statutes and authorities; including but not limited to:

Pertinent Nondiscrimination Authorities:

- Title VI of the Civil Rights Act of 1964 (42 U.S.C. § 2000d et seq., 78 stat. 252), (prohibits discrimination on the basis of race, color, national origin); and 49 CFR Part 21.
- The Uniform Relocation Assistance and Real Property Acquisition Policies Act of 1970, (42 U.S.C. § 4601), (prohibits unfair treatment of persons displaced or whose property has been acquired because of Federal or Federal-aid programs and projects);
- Federal-Aid Highway Act of 1973, (23 U.S.C. § 324 et seq.), (prohibits discrimination on the basis of sex);
- Section 504 of the Rehabilitation Act of 1973, (29 U.S.C. § 794 et seq.), as amended, (prohibits discrimination on the basis of disability); and 49 CFR Part 27;
- The Age Discrimination Act of 1975, as amended, (42 U.S.C. § 6101 et seq.), (prohibits discrimination on the basis of age);
- Airport and Airway Improvement Act of 1982, (49 U.S.C. § 4 71, Section 4 7123), as amended, (prohibits discrimination based on race, creed, color, national origin, or sex);
- The Civil Rights Restoration Act of 1987, (PL 100-209), (Broadened the scope, coverage and applicability of Title VI of the Civil Rights Act of 1964, The Age Discrimination Act of 1975 and Section 504 of the Rehabilitation Act of 1973, by expanding the definition of the terms “programs or activities” to include all of the programs or activities of the Federal-aid recipients, subrecipients and contractors, whether such programs or activities are Federally funded or not);
- Titles II and III of the Americans with Disabilities Act, which prohibit discrimination on the basis of disability in the operation of public entities, public and private transportation systems, places of public accommodation, and certain testing entities (42 U.S.C. §§ 12131-12189) as implemented by Department of Transportation regulations at 49 C.F.R. parts 37 and 38;
- The Federal Aviation Administration's Nondiscrimination statute (49 U.S.C. §47123) (prohibits discrimination on the basis of race, color, national origin, and sex);
- Executive Order 12898, Federal Actions to Address Environmental Justice in Minority Populations and Low-Income Populations, which ensures nondiscrimination against minority populations by discouraging programs, policies, and activities with disproportionately high and adverse human

health or environmental effects on minority and low-income populations;

- Executive Order 13166, Improving Access to Services for Persons with Limited English Proficiency, and resulting agency guidance, national origin discrimination includes discrimination because of limited English proficiency (LEP). To ensure compliance with Title VI, you must take reasonable steps to ensure that LEP persons have meaningful access to your programs (70 Fed. Reg. at 74087 to 74100); and
- Title IX of the Education Amendments of 1972, as amended, which prohibits you from discriminating because of sex in education programs or activities (20 U.S.C. 1681 etseq).
<https://dot.ca.gov/-/media/dot-media/programs/local-assistance/documents/title-vi/appendix-e-of-the-title-v-i-assurances.pdf>